

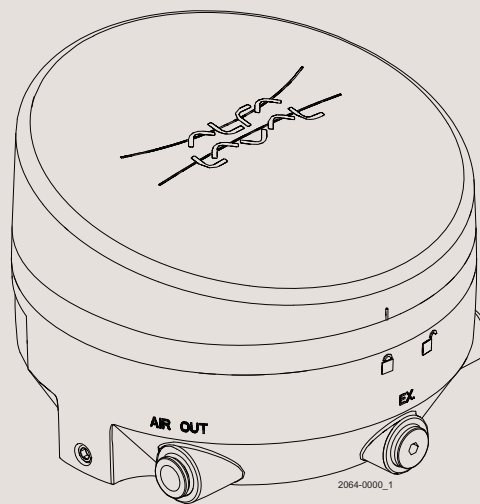

Instruction Manual

ThinkTop® D30



Patented Sensor System
Registered Design
Registered Trademark

ESE02248-EN3 2014-12

Original manual

The information herein is correct at the time of issue but may be subject to change without prior notice

1. EC Declaration of Conformity	4
2. Safety	5
2.1. Important information	5
2.2. Warning signs	5
2.3. Safety precautions	5
3. General information	6
3.1. Concept	6
3.2. Working principle	6
3.3. Recycling information	6
4. Installation	7
4.1. Product dimensions	7
4.2. Compatible actuators	7
4.3. Installation instructions	8
4.4. Operating LED feedback	10
5. Troubleshooting	11
6. Technical data	12
7. Parts list	14
7.1. Parts list	14

1 EC Declaration of Conformity

Revision of Declaration of Conformity 2009-12-29

The Designated Company

Alfa Laval Kolding A/S

Company Name

Albuen 31, DK-6000 Kolding, Denmark

Address

+45 79 32 22 00

Phone No.

hereby declare that

Top Unit for Valve Control and Indication

Designation

ThinkTop® D30

Type

is in conformity with the following directive with amendments:

- Low Voltage Directive (LVD) 2006/95/EC
- EMC Directive 2004/108/EC
- RoHS2 Directive 2011/65/EU

The person authorised to compile the technical file is the signer of this document

QHSE Manager, Quality, Health and safety & Environment

Title

Annie Dahl

Name

Kolding

Place

2013-12-03

Date



Signature



*Unsafe practices and other important information are emphasised in this manual.
Warnings are emphasised by means of special signs. All warnings in the manual are summarised on this page.
Pay special attention to the instructions below so that serious personal injury or damage to the top unit are avoided.*

2.1 Important information

Always read the manual before using the ThinkTop!

WARNING

Indicates that special procedures must be followed to avoid serious personal injury.

CAUTION

Indicates that special procedures must be followed to avoid damage to the ThinkTop D30.

NOTE

Indicates important information to simplify or clarify procedures.

2.2 Warning signs

General warning:



Dangerous electrical voltage:



Caustic agents:



2.3 Safety precautions

Installation:

Always read the technical data thoroughly

Never install the ThinkTop D30 before the valve or relay is in a safe position

If welding close to the ThinkTop D30: **Always** earth close to the welding area

Disconnect the ThinkTop D30



Always have the ThinkTop D30 electrically connected by authorised personnel



Maintenance:

Always read the technical data thoroughly

Always fit the seals between the valve and ThinkTop D30 correctly

Never install the ThinkTop D30 before valve or relay is in a safe position

Never service the ThinkTop D30 with the valve/actuator under pressure

Never clean the ThinkTop D30 with high pressure cleaning equipment

Never touch the moving parts if the actuator is supplied with compressed air

Never use cleaning agents that will attack the exterior of the ThinkTop D30. Check with your cleaning agent supplier



Never clean using Alcohol, Acetone, Chloroform, Methanol, Ammonium chloride and Ammonium Hydroxide etc.

3 General information

3.1 Concept

The ThinkTop D30 is designed to ensure valve control in a basic market, using Alfa Laval air operated actuators such as butterfly, single and double-seat valves. It is compatible with all major PLC systems (Programmable Logic Controller) with a digital PNP interface.

It is for use in food, dairy and brewery installations. ThinkTop D30 is a complementary, alternative solution to the existing range of control units.

ThinkTop D30 is the first of its kind on the market that focuses on new methods to simplify all aspects of using a basic control unit to minimise and optimise installations instead of using external solenoid valves

3.2 Working principle

The ThinkTop D30 is an easy-to-use plug 'n play control unit with integrated intelligence which monitors the status of the operating air pressure, identifying air leakage or failing air pressure. The integrated solenoid valve allows control of the processing valve.

Mounted on top of the valve, the unit receives signals from a PLC system to control the solenoid valve and it returns the supervised air pressure signals for valve energised or de-energised feedback to the PLC system. The ThinkTop D30 has a 360 degree visual valve status indicator, which can be seen at a distance and at any angle.

3.3 Recycling information

- **Unpacking**

- Packing material consists of wood, plastics, cardboard boxes and in some cases metal straps
- Wood and cardboard boxes can be reused, recycled or used for energy recovery
- Plastics should be recycled or burnt at a licensed waste incineration plant
- Metal straps should be sent for material recycling

- **Scrapping**

- At the end of use, the equipment should be recycled according to relevant, local regulations. In addition to the actual equipment, any hazardous residues from the process liquid must be considered and disposed of in a proper manner. When in doubt, or in the absence of local regulations, please contact your local Alfa Laval representative.
-

4.1 Product dimensions

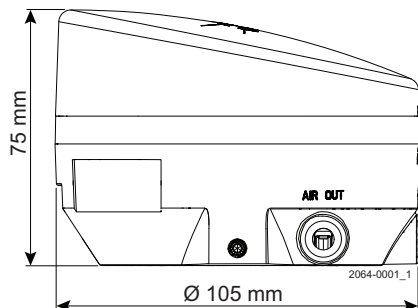

4.2 Compatible actuators

SBV	Yes
Koltek	Yes
LKLA-T	Yes
LKLA	No
ARC	Yes
SRC	Yes
SRC long stroke	No
i-SSV	Yes
Unique SSV	Yes
Unique SSV long stroke	No
SSV DN80 (76.1 mm) High pressure	No
SSV DN100 (101.6 mm) High pressure	No
SMP valves	Yes
Unique Mixproof	No
Air/air actuators	No

4 Installation

4.3 Installation instructions

Step 1

Place the ThinkTop D30 on top of the actuator.
Ensure that the unit is correctly mounted by pressing down on top of the ThinkTop D30.
Cross-tighten the two allen screws carefully (1.50 Nm).



When mounting the ThinkTop D30 on a horizontal mounted actuator make sure that the exhaust port is not pointing upwards. The exhaust port is marked with "EX.".

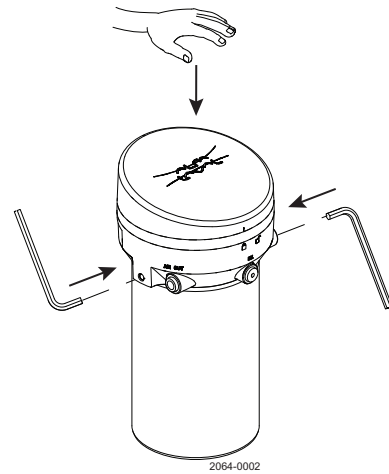

Step 2

Connect the air supply to the air-in port (A).
Connect the air-out port (B) to the actuator.

NOTE!

Option in case of a 1/4" air supply hose system.
Connect the air supply hose via an $\varnothing 6 / 1/4$ " angle adaptor.

The angle adaptor is sold separately:
Article number: 9611-99-5679, $\varnothing 6 / 1/4$ " angle adaptor.
The angle adaptor is also available as $\varnothing 6 / \varnothing 6$:
Article number: 9611-99-5678, $\varnothing 6 / \varnothing 6$ angle adaptor.

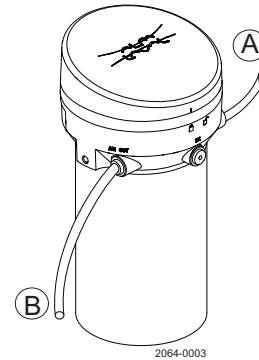

Step 3

Remove the top cover by turning the top cover anti-clockwise.
When the mark on the top cover (C) is aligned with the open padlock symbol (D), the top cover can be lifted off.

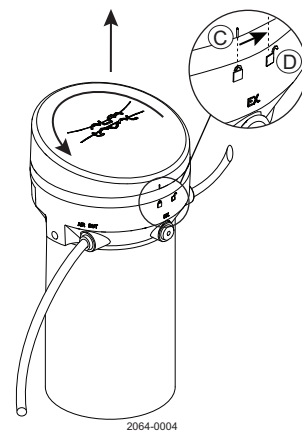

Step 4

Install the cable in the cable gland.

NOTE

Cable connection

Cable gland: PG7 (cable dia. $\varnothing 4.0 - \varnothing 6.8$ mm)

Recommended conductor cross section: 0.5 mm^2 (AWG 20).



If the cable gland comes loose from the control head during installation, it must be secured with a tightening torque of 1.50 Nm.



To fulfil the UL requirements in UL61010, the unit must be supplied by an isolating source that complies with the requirements for class 2 power units (UL1310) or class 2 and 3 transformers (UL1585).

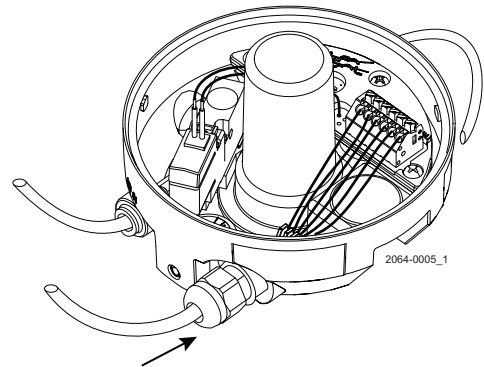

Electrical connection

Digital Interface
Sensor board
Terminal strip

Connection of power supply	{	GND
		24 VDC
PLC output signal	{	Trigger solenoid
PLC input signals	{	Alarm
		De-energised
		Energised

-
+
T
A
D
E

Step 5

Put the top cover back on by pushing it down when the mark on the top cover (E) and the open padlock (F) are aligned. Then turn it clockwise towards the closed padlock (G) to secure the top cover.

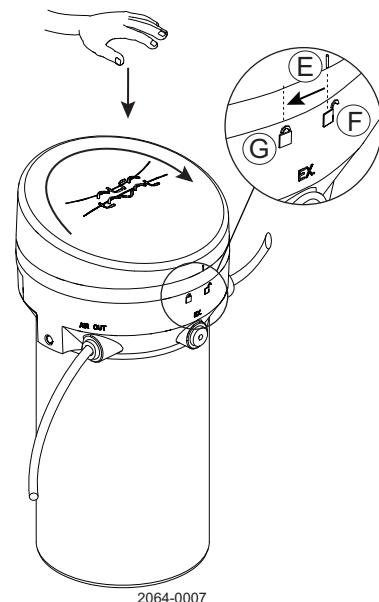

4 Installation

4.4 Operating LED feedback

Actuator status	LED feedback
De-energised	Green
Energised	Yellow
Alarm (Air pressure)	Red flashing

Error scenarios

Condition	Possible cause	Solution
Red LED flashing.	Insufficient air pressure in the actuator.	Check the air supply and the air connections on the unit.

6 Technical data

Technical data

General		
Operating pressure	400 - 700 kPa (4-7 bar)	
Supply air quality	Class 3	ISO 8573-1
Push-in fittings	ø6 mm tube	
Ambient temperature (operating)	-10°C to +50°C	
Storage temperature (non operating)	-15°C to +60°C	
Protection class	IP66 and IP67	IEC 60529
Approvals		
UL listed	Rated: 24V, 39mA Class 2 input	UL 61010
CSA listed	Environment type 1	C22.2 No. 61010
Communication		
Interface	Digital - PNP	EN61131-2
Supply voltage	24 VDC ± 10%	
Current consumption - solenoid active	39 mA	
Current consumption - solenoid inactive	28 mA	
Short circuit and brownout protection	Yes	EN61131-2
Solenoid valve		
Type of solenoid	3/2 NC	
Number of solenoids	1	
Manual override	Yes (Non-locking)	
Actuation flow (at 6 bar)	160 l/min	
Exhaust flow (at 6 bar)	140 l/min	
Physical data		
Materials		
Body	Black nylon PA 6 (reinforced)	
Light guide	Transparent polyamide	
Seals	Nitrile (NBR)	
Cable connection		
Cable gland	PG7 (cable range ø4.0 - ø6.8 mm)	
Recommended conductor cross section	0.5 mm ² (AWG20)	
Terminal block connection data		
Conductor cross section min.	0.5 mm ² (AWG20)	
Conductor cross section max.	1.5 mm ² (AWG16)	

7 Parts list

7.1 Parts list

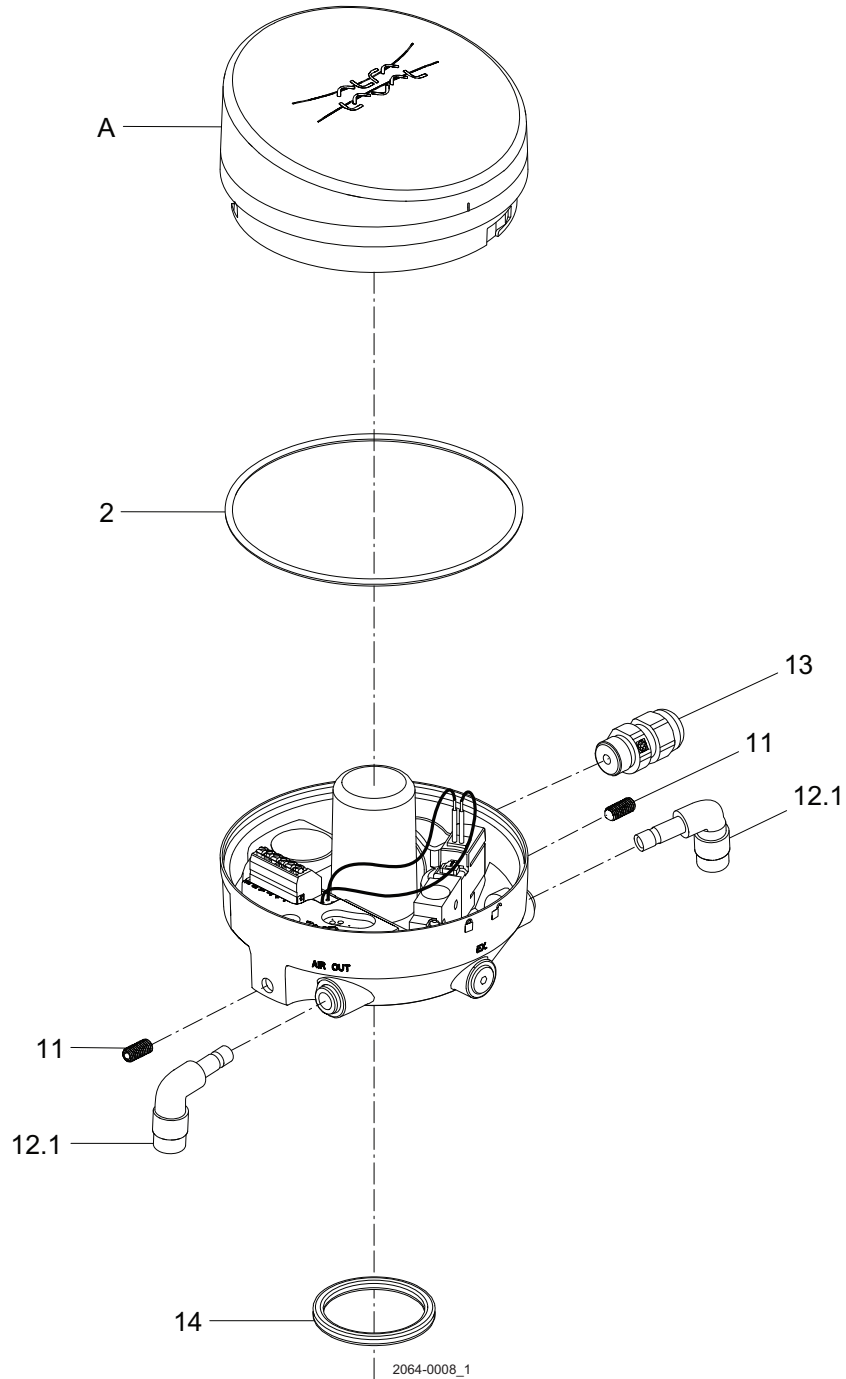

Parts list

Pos.	Qty	Denomination
A		Top incl. prism and O-rings
2	1	O-ring
11	2	Allen screw
12.1	1	Air fitting
13	1	Cable gland PG7
14	1	X-ring

How to contact Alfa Laval

Contact details for all countries are continually updated on our website.

Please visit www.alfalaval.com to access the information directly.

© Alfa Laval Corporate AB

This document and its contents is owned by Alfa Laval Corporate AB and protected by laws governing intellectual property and thereto related rights. It is the responsibility of the user of this document to comply with all applicable intellectual property laws. Without limiting any rights related to this document, no part of this document may be copied, reproduced or transmitted in any form or by any means (electronic, mechanical, photocopying, recording, or otherwise), or for any purpose, without the expressed permission of Alfa Laval Corporate AB. Alfa Laval Corporate AB will enforce its rights related to this document to the fullest extent of the law, including the seeking of criminal prosecution.