

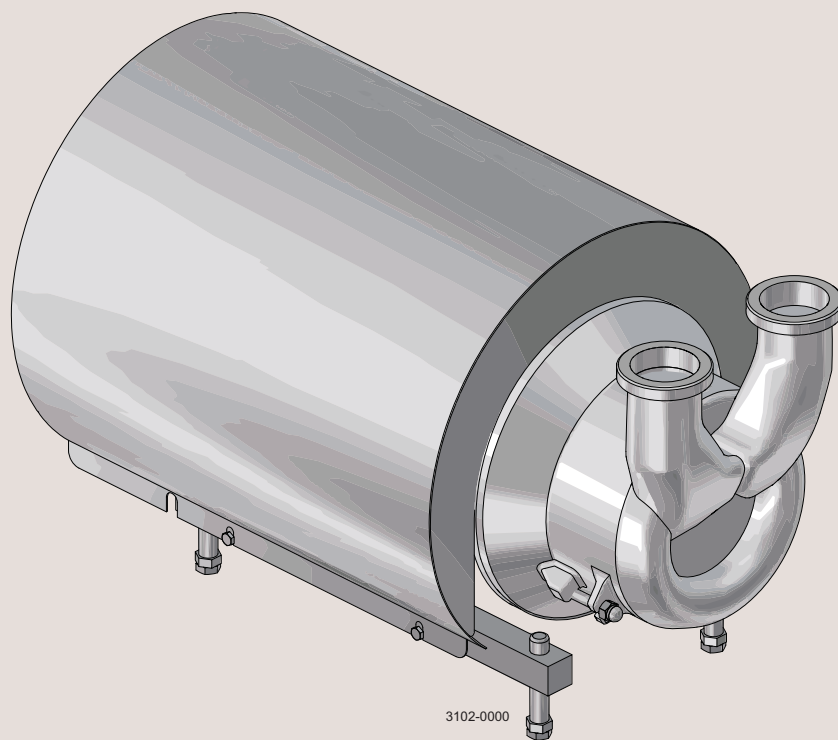

Instruction Manual

MR-300 Liquid-Ring Pump



ESE02051-EN2 2014-09

Original manual

The information herein is correct at the time of issue but may be subject to change without prior notice

1. EC Declaration of Conformity	4
2. Safety	5
2.1. Important information	5
2.2. Warning signs	5
2.3. Safety precautions	6
3. Installation	7
3.1. Unpacking/delivery	7
3.2. Installation/pre-use check	8
3.3. Recycling information	10
4. Operation	11
4.1. Operation/control	11
4.2. Trouble shooting	12
4.3. Recommended cleaning	13
5. Maintenance	14
5.1. General maintenance	14
5.2. Dismantling of pump/removing the shaft seal (1-4*)	16
5.3. Assembly of pump/fitting of shaft seal (5-8*)	17
5.4. Adjustment of impeller position	18
6. Technical data	19
6.1. Technical data	19
6.2. Torque specifications	20
6.3. Weight (kg)	20
6.4. Noise emission	21
7. Parts list and service kits	22
7.1. Drawings	22
7.2. MR-300	24

1 EC Declaration of Conformity

Revision of Declaration of Conformity 2009-12-29

The Designated Company

Alfa Laval Kolding A/S

Company Name

Albuen 31, DK-6000 Kolding, Denmark

Address

+45 79 32 22 00

Phone No.

hereby declare that

Pump

Designation

MR-300

Type

From serial number 10.000 to 1.000.000

is in conformity with the following directive with amendments:

- Machinery Directive 2006/42/EC

The person authorised to compile the technical file is the signer of this document

QHSE Manager, Quality, Health and
safety & Environment

Title

Annie Dahl

Name

Kolding
Place

2013-12-03
Date



Signature



*Unsafe practices and other important information are emphasised in this manual.
Warnings are emphasised by means of special signs. All warnings in the manual are summarised on this page.
Pay special attention to the instructions below so that severe personal injury or damage to the pump are avoided.*

2.1 Important information

Always read the manual before using the pump!

WARNING

Indicates that special procedures must be followed to avoid serious personal injury.

CAUTION

Indicates that special procedures must be followed to avoid damage to the pump.

NOTE

Indicates important information to simplify or clarify procedures.

2.2 Warning signs

General warning:



Dangerous electrical voltage:



Caustic agents:



2 Safety

Unsafe practices and other important information are emphasised in this manual.

Warnings are emphasised by means of special signs. All warnings in the manual are summarised on this page.

Pay special attention to the instructions below so that severe personal injury or damage to the pump are avoided.

2.3 Safety precautions

Installation:

Always read the technical data thoroughly. (See chapter 6 Technical data)

Always use a lifting crane when handling the pump.



Operation:

Always read the technical data thoroughly. (See chapter 6 Technical data)

Never touch the pump or the pipelines when pumping hot liquids or when sterilising.

Never run the pump with both the suction side and the pressure side blocked.

Never run the pump when partially installed or not completely assembled.

Necessary precautions must be taken if leakage occurs as this can lead to hazardous situations.

Always handle lye and acid with great care.

Never use the pump for products not mentioned in the Alfa Laval pump selection program.

The Alfa Laval pump selection program can be acquired from your local Alfa Laval sales company.



Maintenance:

Always read the technical data thoroughly. (See chapter 6 Technical data)

Never service the pump when it is hot.

Never service the pump if pressurised.

Always use Alfa Laval genuine spare parts.

Always disconnect the power supply when servicing the pump.



Transportation:

Transportation of the pump or the pump unit:

Never lift or elevate in any way other than as described in this manual

Always drain the pump head and accessories of any liquid

Always ensure that no leakage of lubricants can occur

Always transport the pump in its upright position

Always ensure that the unit is securely fixed during transportation

Always use original packaging or similar during transportation

3.1 Unpacking/delivery

Step 1

CAUTION

Alfa Laval cannot be held responsible for incorrect unpacking.
Inspect the pump for visible transport damage.

Check the delivery for:

1. Complete pump.
 2. Delivery note.
 3. Motor instructions.
-

Step 2

Clean the inlet and the outlet to remove possible packing materials.

Step 3

Avoid damaging the inlet and the outlet.

Step 4

Always remove the shroud, if fitted, before lifting the pump.

3 Installation

Read the instructions carefully and pay special attention to the warnings!

The direction of rotation of the impeller can be checked by observing the direction of rotation of the motor fan.

- See the indication label on the pump.

3.2 Installation/pre-use check

Step 1



Always read the technical data thoroughly.

See chapter 6 Technical data

CAUTION

Alfa Laval cannot be held responsible for incorrect installation.



Never stick your fingers or any tool through the adaptor or the drain hole in the pump casing when the pump is running.

WARNING:

Alfa Laval recommends the installation of a lockable repair breaker. If the repair breaker is to be used as an emergency stop, the colours of the repair breaker must be red and yellow.

CAUTION

The pump does not prevent back flow when intentionally or unintentionally stopped. If back flow can cause any hazardous situations, precautions must be taken e.g. a check valve must be installed in the system to prevent this from happening.

NOTE!

In case of shaft seal leakage, the media will drip from the slot in the bottom of the adaptor. In case of shaft seal leakage, Alfa Laval recommends placing a drip tray underneath the slot for collecting the leakage.

Step 2

Ensure at least 0.5 m clearance around the pump.

Step 3

Ensure that the flow direction is correct.

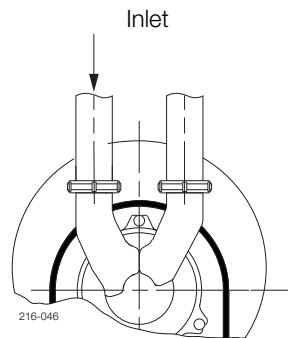

Step 4

1. Ensure that the pipelines are correctly routed.
2. Ensure that connections are tight.

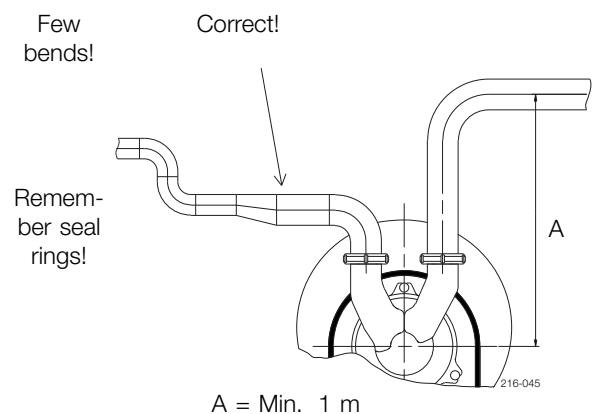

Step 5

Avoid stresses to the pump.

Pay special attention to:

- Vibrations.
- Thermal expansion of the tubes.
- Excessive welding.
- Overloading of the pipelines.

Risk of damage!

3 Installation

Read the instructions carefully and pay special attention to the warnings!

The direction of rotation of the impeller can be checked by observing the direction of rotation of the motor fan.

- See the indication label on the pump.

Step 6



Never test the direction of rotation with liquid in the pump.

Pre-use check:

1. Start and stop the motor momentarily.
2. Ensure that the direction of rotation of the motor is clockwise as viewed from the back of the motor.

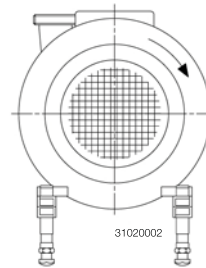

3 Installation

3.3 Recycling information

- **Unpacking**

- Packing material consists of wood, plastics, cardboard boxes and in some cases metal straps.
- Wood and cardboard boxes can be reused, recycled or used for energy recovery.
- Plastics should be recycled or burnt at a licensed waste incineration plant.
- Metal straps should be sent for material recycling.

- **Maintenance**

- During maintenance, oil and wear parts in the machine are replaced.
- All metal parts should be sent for material recycling.
- Worn out or defective electronic parts should be sent to a licensed handler for material recycling.
- Oil and all non-metal wear parts must be taken care of in agreement with local regulations.

- **Scrapping**

- At the end of use, the equipment shall be recycled according to the relevant, local regulations. Besides the equipment itself, any hazardous residues from the process liquid must be considered and dealt with in a proper manner. When in doubt, or in the absence of local regulations, please contact your local Alfa Laval sales company.
-

Study the instructions carefully and pay special attention to the warnings!

4.1 Operation/control

Step 1



Always read the technical data thoroughly.

CAUTION

Alfa Laval cannot be held responsible for incorrect operation/control.

Step 2



Never touch the pump or the pipelines when pumping hot liquids or when sterilising.

Danger of burns!



Step 3

Never run the pump with both the suction side and the pressure side blocked.

Danger of explosion!

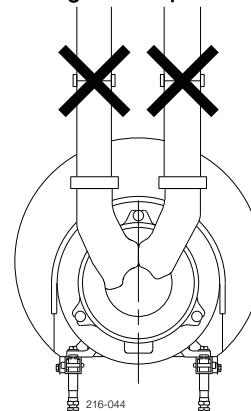

Step 4



Never stick your fingers or any tool through the adaptor or the drain hole in the pump casing when the pump is running.

Rotating parts!

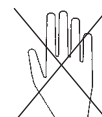

Step 5

CAUTION

The shaft seal must not run dry.

CAUTION

Never throttle the inlet side.

Step 6

Control:

Reduce the capacity by means of:

- Throttling the pressure side of the pump.
- Speed control of the motor.

4 Operation

*Pay attention to possible faults.
Study the instructions carefully.*

4.2 Trouble shooting

NOTE!

Study the maintenance instructions carefully before replacing worn parts.

Problem	Cause/result	Remedy
Overload motor	<ul style="list-style-type: none">- Pumping of viscous liquid- Pumping of high density liquids	<ul style="list-style-type: none">- 18.5 kW motor if 15 kW is fitted- Increase capacity
Leaking shaft seal	<ul style="list-style-type: none">- Dry run- Incorrect rubber grade	Replace: All wearing parts <ul style="list-style-type: none">- Select a different rubber grade
Leaking O-ring seals	Incorrect rubber grade	Change rubber grade

The pump is designed for cleaning in place (CIP). CIP = Cleaning In Place.
 Study the instructions carefully and pay special attention to the warnings!
 NaOH = Caustic Soda.
 HNO₃ = Nitric acid.

4.3 Recommended cleaning

Step 1



Always handle lye and acid with great care.

Caustic danger!



Always use rubber gloves!



Always use protective goggles!

Step 2



Never touch the pump or the pipelines when pumping hot liquids or when sterilising.

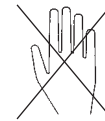

Danger of burns!

Step 3

Examples of cleaning agents: Use clean water, free from chlorides.

1. 1% by weight NaOH at 70°C (158°F).

1 kg (2.2 lb) NaOH	+	100 l (26.4 gal) water	= Cleaning agent.
-----------------------	---	---------------------------	-------------------

2.2 l (0.6 gal) 33% NaOH	+	100 l (26.4 gal) water	= Cleaning agent.
-----------------------------	---	---------------------------	-------------------

2. 0.5% by weight HNO₃ at 70°C (158°F).

0.7 l (0.2 gal) 53% HNO ₃	+	100 l (26.4 gal) water	= Cleaning agent.
---	---	---------------------------	-------------------

1. Avoid excessive concentration of the cleaning agent
 ⇒ Dose gradually!
2. Adjust the cleaning flow to the process.
 Sterilisation of milk/viscous liquids
 ⇒ Increase the cleaning flow!

Step 4



Always rinse well with clean water after using a cleaning agent.

NOTE

The cleaning agents must be stored/disposed of in accordance with current regulations/directives.

Always rinse!



Clean water

Cleaning agent

5 Maintenance

Maintain the pump carefully. Study the instructions carefully and pay special attention to the warnings! Always keep spare shaft seals and rubber seals in stock. See separate motor instructions.

5.1 General maintenance

Step 1



Always read the technical data thoroughly.



Always disconnect the power supply when servicing the pump.
Always disconnect the power supply when checking the impeller position.

NOTE

All scrap must be stored/discharged in accordance with current rules/directives.

Step 2



Never service the pump when it is hot.



The pump and the pipelines must **never** be pressurised when the pump is serviced.

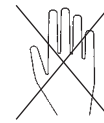

Danger of burns!

Step 3

CAUTION

Always ensure that the impeller rotates smoothly after service.

1. Ensure that impeller (19) does not come into contact with pump casing (8) or casing cover (23).
 2. Adjust the impeller position if necessary (see page 17).
-

Step 4

CAUTION

Fit the electrical connections correctly if they have been removed from the motor during service.

Pay special attention to the warnings!

Ordering spare parts

Contact your local Alfa Laval sales company.

Recommended spare parts:

Order Service kits from the Service kits list (see chapter 7 Parts list and service kits).

5 Maintenance

Maintain the pump carefully. Study the instructions carefully and pay special attention to the warnings! Always keep spare shaft seals and rubber seals in stock. See separate motor instructions.

	Shaft seals	Rubber seals	Motor bearings
Preventive maintenance	Replace after 12 months (one-shift) Complete shaft seal	Replace when replacing the shaft seal	
Maintenance after leakage (leakage normally starts slowly)	Replace at the end of the day: Complete shaft seal	Replace when replacing the shaft seal	
Planned maintenance	<ul style="list-style-type: none"> - Regular inspection for leakage and smooth operation - Keep a record of the pump - Use the statistics for inspection planning Replace after leakage: Complete shaft seal	Replace when replacing the shaft seal	Yearly inspection is recommended <ul style="list-style-type: none"> - Replace complete bearing if worn - Ensure that the bearing is axially locked (See motor instructions)
Lubrication	Before fitting Lubricate the O-rings with silicone grease or silicone oil	Before fitting Silicone grease or silicone oil	See section

5 Maintenance

Study the instructions carefully. The items refer to the parts list and service kits section. Handle scrap correctly.

5.2 Dismantling of pump/removing the shaft seal (1-4*)

Step 1

*

Remove cap nuts (25), washers (24) and casing cover (23)

Step 2

*

1. Remove impeller screw (21), washer (20) and O-ring (22), (counterhold impeller (19), with the tool supplied).
2. Remove the impeller.

NOTE!

Ensure that shims (18) remain in the impeller.

Step 3

*

1. Remove rotating seal ring (14) from impeller (19) by turning it clockwise and pulling it simultaneously.
 2. Remove O-ring (15) washer (16) and spring (17) from the rotating seal ring.
-

Step 4

*

1. Remove stationary seal ring (13) from pump casing (8) by hooking the tool supplied to the rear edge of the seal ring and pulling it out.
 2. Remove O-ring (12) from the stationary seal ring.
-

Step 5

Remove O-ring (11) from pump casing (8).

Step 6

Remove shroud (2).

Step 7

1. Remove screws (6) and washers (7).
 2. Remove pump casing (8).
-

Step 8

1. Remove thrower (10) from the motor shaft.
-

Study the instructions carefully. The items refer to the parts list and service kits section. Lubricate the rubber seals before fitting them.

5.3 Assembly of pump/fitting of shaft seal (5-8*)

Step 1

NOTE!

The impeller position may have to be adjusted if:

- The motor has been replaced.
- Shims (18) are missing in impeller (19).

(For impeller adjustment, see page 18).

Step 2

1. Fit thrower (10) on the motor shaft.
 2. Fit pump casing (8) on the motor.
 3. Fit washers (7) and screws (6).
-

Step 3

1. Fit shrouds (2).
-

Step 4

1. Fit O-ring (11) on pump casing (8).
-

Step 5

* *

1. Lubricate O-ring (12) and fit it on stationary seal ring (13).
 2. Fit the stationary seal ring in pump casing (8).
-

Step 6

* *

1. Lubricate O-ring (15).
 2. Fit the O-ring, washer (16) and spring (17) in rotating seal ring (14).
 3. Fit the rotating seal ring by turning it clockwise and pressing it simultaneously.
-

Step 7

* *

1. Check that shims (18) are positioned correctly in impeller (19).
 2. Fit the impeller.
 3. Fit O-ring (22) on impeller screw head (21).
 4. Fit washer (20) and the impeller screw (tighten firmly while counterholding the impeller with the tool supplied).
 5. Check that the clearance between the impeller and pump casing (8) is 0.3 - 0.4 mm.
-

Step 8

* *

1. Fit casing cover (23), washers (24) and cap nuts (25).
2. Tighten the cap nuts firmly.
3. Ensure that impeller (19) rotates smoothly (see page 8).

Pay special attention to the warnings!

5 Maintenance

Study the instructions carefully. The items refer to the parts list and service kits section.

5.4 Adjustment of impeller position

Step 1

NOTE!

- Adjust the impeller position with **only** the pump casing, the thrower and the impeller fitted on the motor.
 - Fit all other parts after the adjustment.
-

Step 2

1. Fit thrower (10) on the motor shaft.
 2. Fit pump casing (8) on the motor.
 3. Fit washers (7) and screws (6).
-

Step 3

Place some shims (18) in impeller (19).

Step 4

1. Fit impeller (19) on the motor shaft.
 2. Fit impeller screw (21) and tighten firmly.
-

Step 5

Adjust the impeller position by adding or removing shims (18) until the clearance between impeller (19) and pump casing (8) is 0.3 - 0.4 mm.

Step 6

CAUTION!

Ensure that the correct number of shims (18) are fitted. Too few or too many shims cause the impeller to come into contact with the pump casing or the casing cover and damage them. The efficiency of the pump may also be affected.

*It is important to observe the technical data during installation, operation and maintenance.
Inform personnel about the technical data.*

6.1 Technical data

MR is a liquid-ring pump specially designed for pumping liquids containing air or gas. The pump is for use in food, chemical, pharmaceutical and similar industries. The pump is mainly used for the CIP-return application. This instruction manual is part of the delivery. Read the instructions carefully.

Data	
Max. inlet pressure	400 kPa (4 bar)
Temperature range	-10°C to +140°C (EPDM)
Max. speed	1800 rpm
Materials	
Product wetted steel parts	AISI 316L
Other steel parts	Stainless steel
Product wetted seals	EPDM (standard)
Alternative seals	Nitrile (NBR) and flourinated rubber (FPM)
Finish	Semi bright
Shaft seal	
Seal type	Mechanical single seal
Material, stationary seal ring	AISI 329 (standard) or AISI 329 with sealing surface of silicon carbide
Material, rotating seal ring	Carbon (standard) or silicon carbide
Material, O-rings	EPDM (standard)
Alternative material, O-rings	Nitrile (NBR) and flourinated rubber (FPM)
Motor	
Standard foot-flanged motor according to IEC metric standard	
4 pol = 1500/1800 rpm. at 50/60 Hz	
IP55 (with drain holes with labyrinth plug), insulation class F	
Motor sizes (kW), 50 Hz	15, 18.5
Motor sizes (kW), 60 Hz	17, 21
Tightening torques: See addendum	
Noise: See addendum	

6 Technical data

*It is important to observe the technical data during installation, operation and maintenance.
Inform personnel about the technical data.*

6.2 Torque specifications

The table below specifies the tightening torques for the screws, bolts and nuts in this pump.

Always use the torques specified below if no other values are stated. This can be a matter of personal safety.

Size	Tightening torque	
	Nm	lbf-ft
M8	20	14.8
M10	40	29.5
M12	67	49.0
M14	110	81.0

6.3 Weight (kg)

Pump Type: MR-300

Size	90	132		160	18.5kW
	2.2kW	5.5kW	7.5kW	11kW	15kW
166S	71				
185S		104			
200S			119	160	
300				188	217

Weight can vary depending of configuration. Weight is only to be seen as a reference value during handling, transporting and packaging.

*It is important to observe the technical data during installation, operation and maintenance.
Inform personnel about the technical data.*

6.4 Noise emission

Pump Type	Sound pressure level (dBA)
LKH-5	60
LKH-10	69
LKH-15	72
LKH-20	70
LKH-25	74
LKH-35	71
LKH-40	75
LKH-45	70
LKH-50	75
LKH-60	77
LKH-70	88
LKH-75	79
LKH-85	86
LKH-90	75
LKH-112	70
LKH-113	69
LKH-114	68
LKH-122	75
LKH-123	77
LKH-124	80
SolidC-1	68
SolidC-2	72
SolidC-3	73
SolidC-4	72
MR-166	76
MR-185	82
MR-200	81
MR-300	82
GM	54
FM-OS	61

The above LKH noise levels are the same for LKHPPF, LKHI, LKH UltraPure, LKH Evap and LKHHex.
The above SolidC noise levels are the same for SolidC UltraPure.

The noise measurements have been carried out with the original motor and shroud, at the approximate Best Efficiency Point (BEP) with water at ambient temperature and at 50 Hz.

Very often, the noise level generated by the flow through the process system (e.g. valves, pipes, tanks etc.) is much higher than that generated by the pump itself. Therefore it is important to consider the noise level from the total system and take the necessary precautions with regard to personal safety if required.

7 Parts list and service kits

*It is important to observe the technical data during installation, operation and maintenance.
Inform personnel about the technical data.*

7.1 Drawings

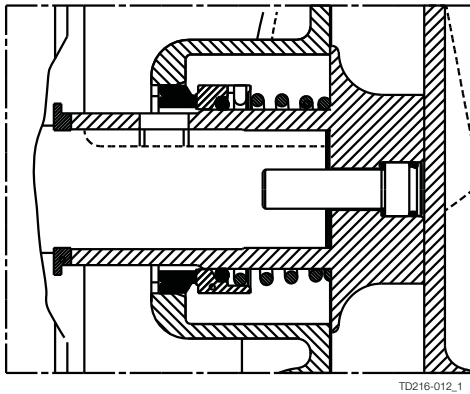
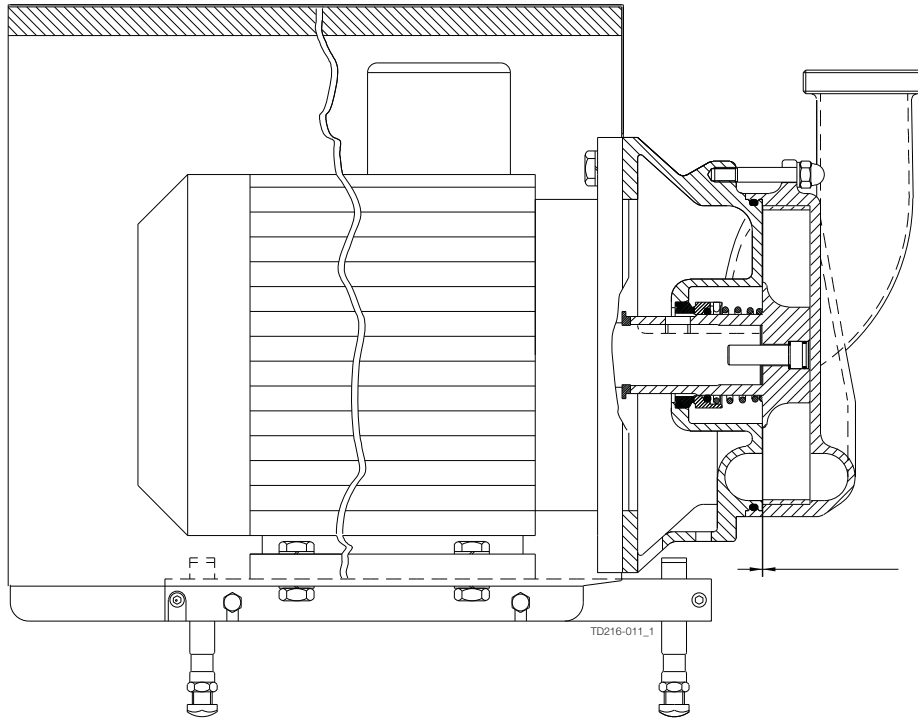

7 Parts list and service kits

It is important to observe the technical data during installation, operation and maintenance.
Inform personnel about the technical data.

7.2 MR-300

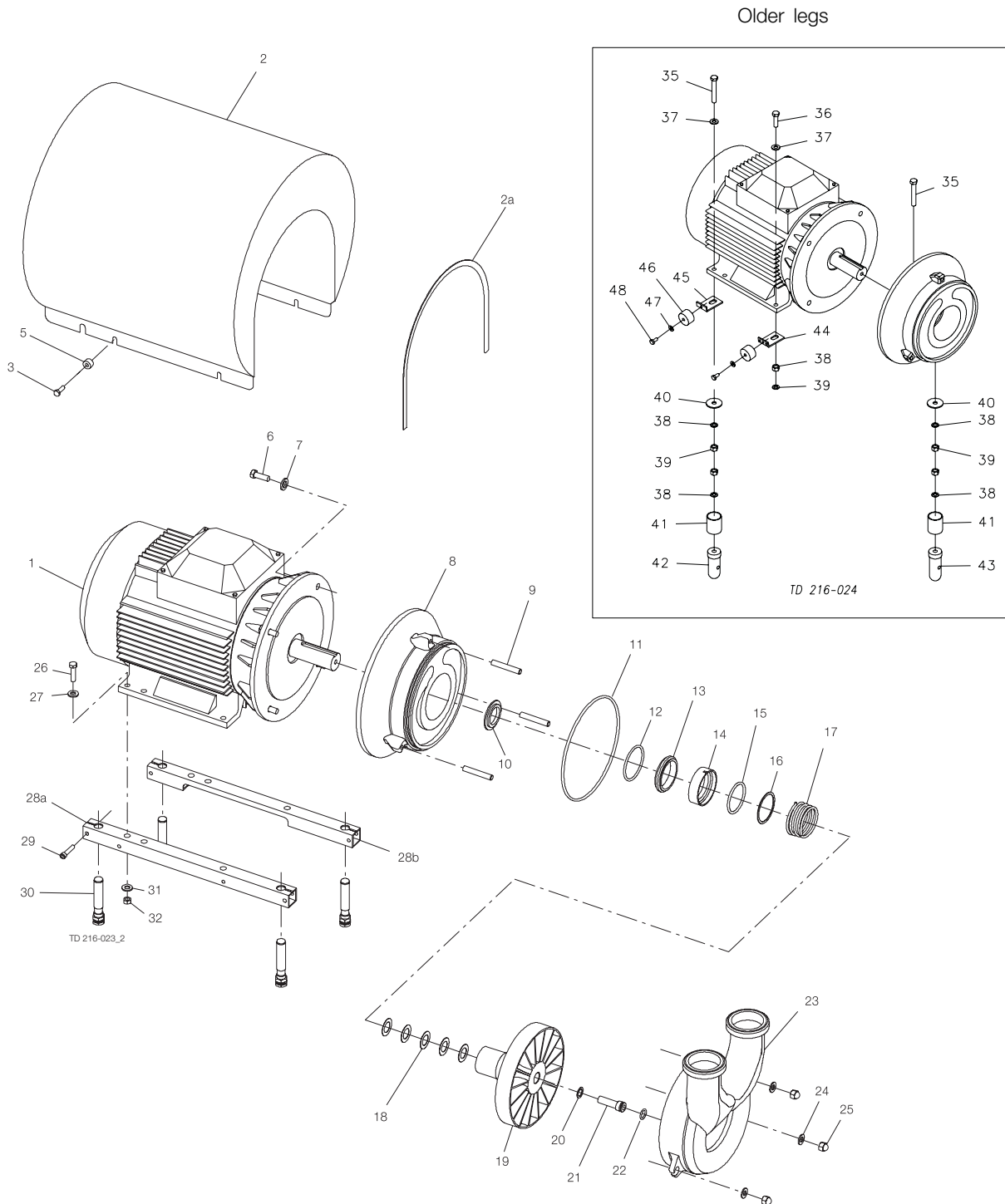

7 Parts list and service kits

*It is important to observe the technical data during installation, operation and maintenance.
Inform personnel about the technical data.*

Parts list

Pos.	Qty	Denomination
	1	Key for hexagonal socket
	1	Impeller tool
□	1	Shaft seal tool Shaft seal complete
1	1	Motor
2	1	Shroud
2a	1	Edge list
3	4	Screw
5	4	Distance sleeve
6	4	Screw
7	4	Spring washer
8	1	Pump casing
9	3	Stud bolt
10	1	Thrower
11	1	O-ring
12	1	O-ring
13	1	Stationary seal ring
14	1	Rotating seal ring
15	1	O-ring
16	1	Washer
17	1	Spring
18	1-2	Shims
19	1	Impeller
20	1	Washer for impeller screw
21	1	Impeller screw
22	1	O-ring
23	1	Cover, 76.2 mm in-/outlet + fitting
	1	ISO male
	1	SMS
	1	DIN
	1	ISO clamp
	1	BS
24	3	Washer (Period 9501-)
25	3	Cap nut (Period 9501-)
25a	1	Handle (Period -9501) (Long)
26	4	Screw (Period 9409-)
27	4	Washer (Period 9409-)
28a	2	Support bar, right (Period 9409-)
28b	2	Support bar, left (Period 9409-)
29	4	Screw (Period 9711-)
30	4	Adjustable leg (Period 9409-)
31	4	Spring washer (Period 9409-)
32	4	Nut
35	3	Screw (Period -9409)
36	2	Screw (Period -9409)
37	4	Washer (Period -9409)
38	8	Spring washer (Period -9409)
39	8	Nut (Period -9409)
40	3	Disk (Period -9409)
41	3	Sleeve nut (Period -9409)
42	2	Back leg (Period -9409)
43	1	Front leg (Period -9409)
44	2	Bracket, front (Period -9409)
45	2	Bracket, back (Period -9409)
46	4	Vibration damper (Period -9409)
47	4	Washer (Period -9409)
48	4	Screw (Period -9409)

Service kits

Denomination	
Service kit	
Service kit, EPDM.....	□ 9611-92-1084
Service kit, NBR.....	□ 9611-92-1085
Service kit, FPM.....	□ 9611-92-1086

Parts marked with □ are included in the Service kits.

Recommended Spare parts: Service kits.

How to contact Alfa Laval

Contact details for all countries are continually updated on our website.

Please visit www.alfalaval.com to access the information directly.

© Alfa Laval Corporate AB

This document and its contents is owned by Alfa Laval Corporate AB and protected by laws governing intellectual property and thereto related rights. It is the responsibility of the user of this document to comply with all applicable intellectual property laws. Without limiting any rights related to this document, no part of this document may be copied, reproduced or transmitted in any form or by any means (electronic, mechanical, photocopying, recording, or otherwise), or for any purpose, without the expressed permission of Alfa Laval Corporate AB. Alfa Laval Corporate AB will enforce its rights related to this document to the fullest extent of the law, including the seeking of criminal prosecution.