

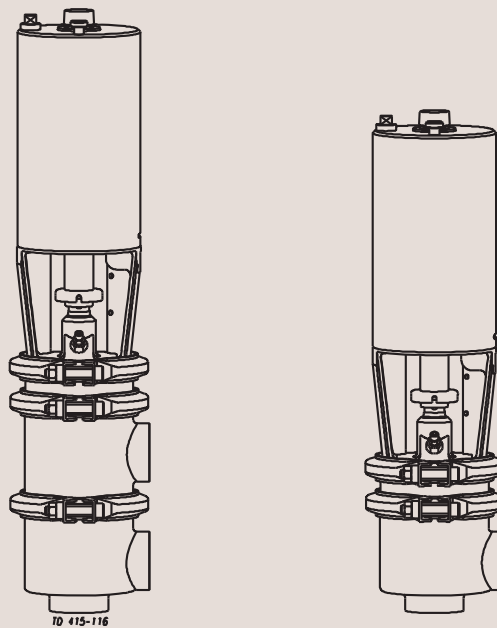

Instruction Manual

ARC Aseptic Remote-Controlled Valve with PTFE diaphragm



IM70727-EN6 2010-03

Original Instructions

This manual is divided into main sections. - See below.

Safety

1. Important information	2
2. Warning signs	2
3. Safety precautions	3

Installation

1. Unpacking/Delivery	4
2. General installation	5
3. Welding	6
4. Fitting of oil damper (optional extra)	7
5. Fitting of indication equipment (optional extra)	8
6. Adjustment of indication equipment (optional extra)	10

Operation

1. Operation	11
2. Fault finding	12
3. Recommended cleaning	13

Maintenance

1. General maintenance	14
2. Dismantling of valve	16
3. Assembly of valve	18
4. Dismantling of actuator	20
5. Assembly of actuator	21

Technical data

1. Technical data	22
-------------------------	----

Drawings/Parts list

1. Parts list	
- ARC	24+26+28+30
- Oil damper	32+34
- Indication units	36
2. Exploded drawing	
- ARC	25+27
- Oil damper	33
- Indication units	37
3. Drawings	
- ARC	29+31
- Oil damper	35

Safety

Unsafe practices and other important information are emphasized in this manual.

Warnings are emphasized by means of special signs.

1. Important information

Always read the manual before using the valve!

2

- WARNING!** : Indicates that special procedures **must** be followed to avoid severe personal injury.
- CAUTION!** : Indicates that special procedures **must** be followed to avoid damage to the valve.
- NOTE!** : Indicates important information to simplify practices or to make them clearer.

2. Warning signs



: General warning.



: Caustic agents.

Transportation:

Always secure that compressed air is released

Always secure that all connections is disconnected before attempt to remove the valve from the installation

Always drain liquid out of valves before transportation

Always used predesigned lifting points if defined

Always secure sufficient fixing of the valve during transportation - if special designed packaging material is available it must be used

All warnings in the manual are summarized on this page.

Pay special attention to the instructions below so that severe personal injury or damage to the valve are avoided.

3. Safety precautions

Installation:



- : - **Always** observe the technical data (see page 22).
- **Always** release compressed air after use.



- : **Never** touch the clip assembly or the actuator piston rod if the actuator is supplied with compressed air.



- : **Never** touch the valve or the pipelines when processing hot liquids or when sterilizing.



- : The valve and the pipelines must **never** be pressurised when dismantling the valve.

Operation:



- : - **Always** observe the technical data (see page 22).
- **Always** release compressed air after use.



- : **Never** touch the valve or the pipelines when processing hot liquids or when sterilizing.



- : **Never** touch the clip assembly or the actuator piston rod if the actuator is supplied with compressed air.



- : **Always** handle lye and acid with great care.

Maintenance:



- : - **Always** observe the technical data (see page 22).
- **Always** release compressed air after use.



- : - The valve must **never** be hot when serviced.
- The valve and the pipelines must **never** be pressurised when the valve is serviced.



- : **Never** stick your fingers through the valve ports if the actuator is supplied with compressed air.



- : **Never** touch the clip assembly or the actuator piston rod if the actuator is supplied with compressed air.

Installation

4

*The instruction manual is part of the delivery.
Study the instructions carefully.
The items refer to the drawings and the parts list on
pages 24-31.*

*The valve is supplied as separate parts as standard
(for welding).
The valve is assembled before delivery, if it is
supplied with fittings.*

1. Unpacking/Delivery

1

NOTE!

We cannot be held responsible for incorrect
unpacking.

Check the delivery:

1. Complete valve, stop valve or change-over
valve (see 2 and 3).
2. Delivery note.
3. Instruction Manual.

2

Delivery of stop valve:

1. Complete actuator with bonnet (8).
2. Clip assembly (11).
3. Intermediate ring (13).
4. Diaphragm ring (21) and seal ring (17), (only
for valve sizes 76-101.6 mm and DN80-100).
5. Diaphragm stem seal (20).
6. Two clamps (15).
7. Valve stem unit (19, 22).
8. Valve body (18).

3

Delivery of change-over valve:

1. Complete actuator with bonnet (8).
2. Clip assembly (11).
3. Intermediate ring (13).
4. Diaphragm ring (21) and seal ring (17), (only
for valve sizes 76-101.6 mm and DN80-100).
5. Diaphragm stem seal (20).
6. Three clamps (15).
7. Valve stem unit (19, 22).
8. Two valve bodies (16, 18).
9. Valve body seal ring (17).

4

Clean the valve/valve parts from possible
packing materials.

5

Inspect the valve/valve parts for visible transport
damage.

6

Avoid damaging the valve/valve parts.

Study the instructions carefully and pay special attention to the warnings!
The valve has welding ends as standard but can also be supplied with fittings.

NO = Normally open.
NC = Normally closed.
A/A = Air/air activated.

2. General installation

1



- **Always** observe the technical data (see page 22).
- **Always** release compressed air after use.

NOTE!

We cannot be held responsible for incorrect installation.

2

Moving parts!

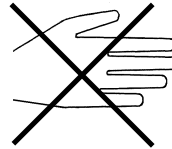

Never touch the clip assembly or the actuator piston rod if the actuator is supplied with compressed air.

3

It is recommended to install the valve so that:

- The actuator is not turned downwards.
- The flow is against the closing direction to avoid water hammer.

4

Risk of damage!

Avoid stressing the valve.

Pay special attention to:

- Vibrations.
- Thermal expansion of the tubes.
- Excessive welding.
- Overloading of the pipelines.

5

Fittings:

Ensure that the connections are tight (remember seal rings).

6

Air connection: R1/8" (BSP)

Connect air correctly:

- NO: Top connection.
- NC: Side connection.
- A/A: Top and side connection.

Installation

6

Study the instructions carefully.
The valve is supplied as separate parts to facilitate the welding.

The items refer to the drawings and the parts list on pages 24-31.
Check the valve for smooth operation after welding.

3. Welding

1

Always weld the valve so that the valve body seal ring can be replaced (change-over valve).

Maintain the minimum clearances (A and B) so that the lower valve plug (change-over valve) and the actuator with the internal valve parts can be removed.

Valve size	A (mm)	B ₁ (mm)	B ₂ (mm)
DN40/38 mm	160	550	730
DN50/51 mm	160	550	730
DN65/63,5 mm	180	550	730
DN80/76 mm	205	600	780
DN100/101,6 mm	240	650	830

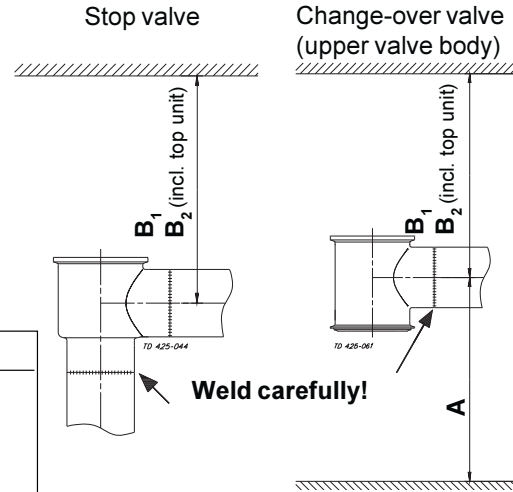

2

Stop valve:
Assemble the valve in accordance with instructions 4-11 on pages 18-19.
Pay special attention to the warnings!

3

Change-over valve:
Assemble the valve in accordance with instructions 3-11 on pages 18-19.
Pay special attention to the warnings!

4

Pre-use check:

1. Supply compressed air to the actuator.
2. Open and close the valve several times to ensure that it operates smoothly.

Pay special attention to the warnings!

The valve can be fitted with an oil damper if water hammer occurs when the valve closes in the flow direction.

Study the instructions carefully and pay special attention to the warnings!
 NC = normally closed.
 A/A = air/air activated.

4. Fitting of oil damper (optional extra)

1

Burning danger!

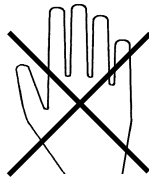

Never touch the valve or the pipelines when processing hot liquids or when sterilizing.

3

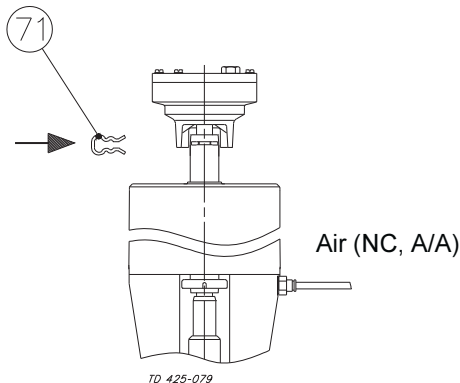

1. Connect the two piston rods by means of clip (71).
2. Release compressed air to the actuator.
Pay special attention to the warnings!

5

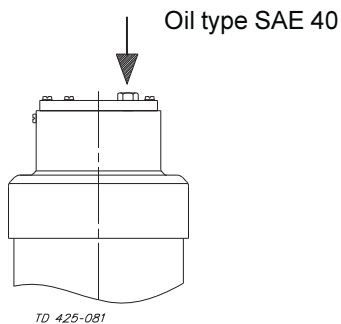

Fill further oil through the plug hole if large air bubbles occur under the plexiglas cover.

NOTE!

There should be a small air bubble which equalizes changes in the pressure because of temperature changes.

2

Ensure that no other equipment is fitted on the actuator top!

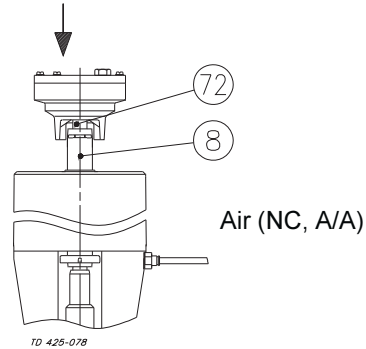

1. Supply compressed air to the actuator.
Pay special attention to the warnings!
2. Fit the damper so that damper piston rod (72) enters actuator piston rod (8).

4

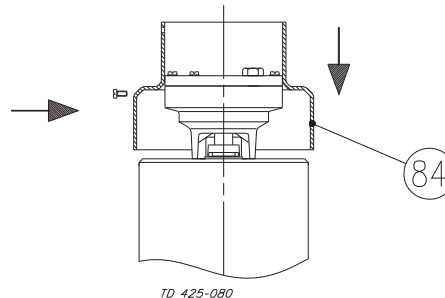

1. Fit protective hood (84).
2. The valve is now ready for operation.

6

Removal/dismantling:

Remove the damper by following the instructions in reverse order.

Pre-use check:

1. Supply compressed air to the actuator.
2. Open and close the valve several times to ensure that it operates smoothly.

Pay special attention to the warnings!

Installation

8

The valve can be fitted with the top unit *ThinkTop*[®]. It can also be fitted with an indication unit.

Study the instructions carefully and pay special attention to the warnings!
The items refer to the drawings and the parts list on pages 36-37.

5. Fitting of indication equipment (optional extra)

1

Atmospheric pressure required!

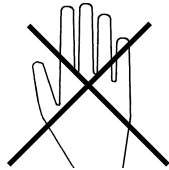

Burning danger!



- The valve must **never** be hot when dismantling it.
- The valve and the pipelines must **never** be pressurised when dismantling the valve.

2

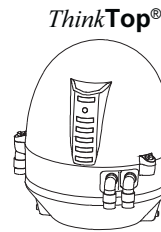

Indication unit

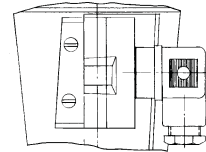

CAUTION!

The indication and control equipment must be electrically installed by authorized personnel.

- *ThinkTop*[®]:
(see the separate instruction manual)
- Indication unit:
(see the instructions on pages 8-10)

3

Dismantle the valve in accordance with instructions 1-2 on page 16.

Pay special attention to the warnings!

4

1. Fit ring (56) on the plug stem.
2. Assemble the valve in accordance with instructions 10-11 on page 19.

Pay special attention to the warnings!

5

Micro switch unit:

1. Assemble and fit the switch unit
2. Turn ring (56) so that the edges of holder (51) guide its movements.
3. Ensure that spring (57) enters the recess in the ring.
4. Fix the switch unit by means of screws (58).

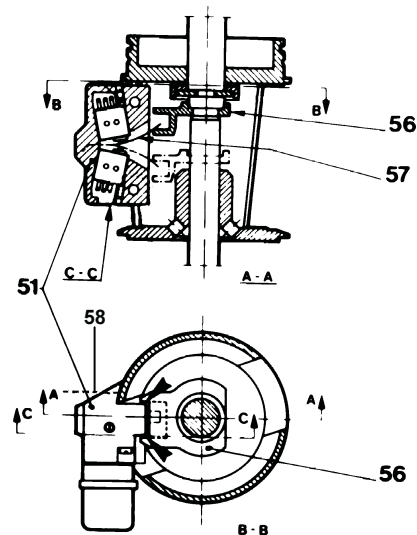

The indication unit has one or two micro switches or an inductive proximity switch.

Study the instructions carefully.
The items refer to the drawings and the parts list on pages 36-37.

5. Fitting of indication equipment (optional extra)

6

Inductive proximity switch unit:

1. Assemble and fit the switch unit
2. Turn ring (56) so that the edges of holder (51) guide its movements.
3. Fix the switch unit by means of screws (58).

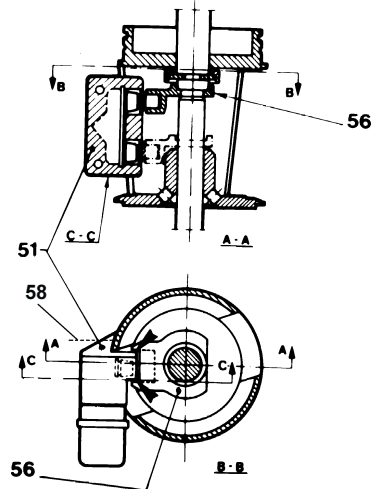

7

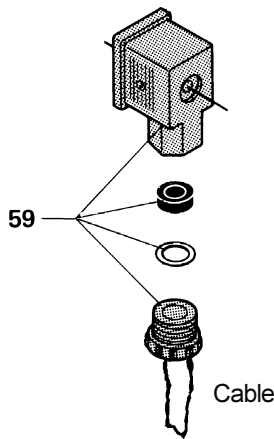

Fit the cable through the cable gland and assemble cable socket (59).

8

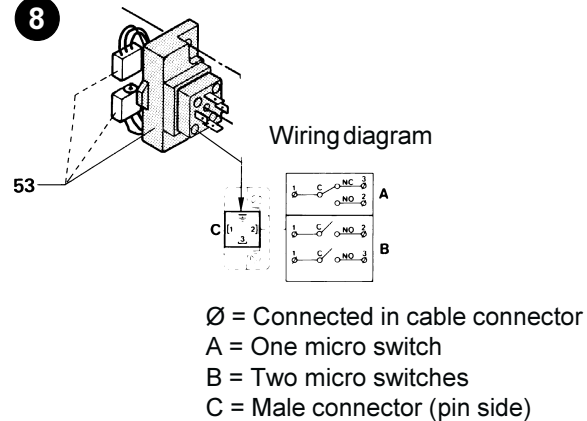

Micro switch unit:

Connect the cable to switch unit (53) as shown in the wiring diagram.

9

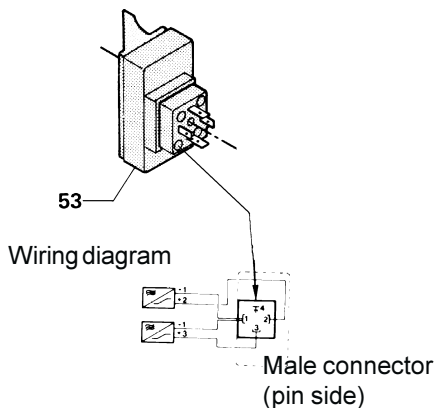

Inductive proximity switch unit:

Connect the cable to switch unit (53) as shown in the wiring diagram.

10

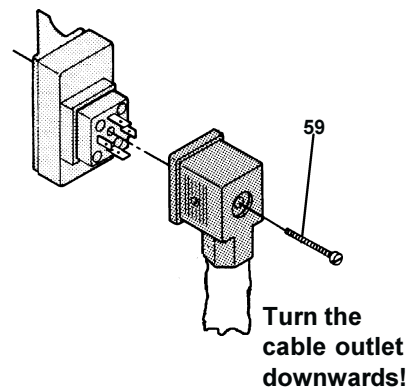

Tighten screw (59) firmly

NOTE!

The cable gland should be sealed with silicone rubber under extreme conditions.

Installation

Adjust the micro switch and inductive proximity switch units after installation.

Study the instructions carefully.

The items refer to the drawings and the parts list on pages 36-37.

10

6. Adjustment of indication equipment (optional extra)

1

Micro switch unit:

(Adjustment of contact point between spring (57) and switch unit (53)).

1. Loosen switch unit (53) slightly (screw (58)).
2. Rotate adjustment screw (60) until a signal is obtained.
3. Tighten the switch unit.
4. Check that the signal is correct.
5. Readjust if necessary.

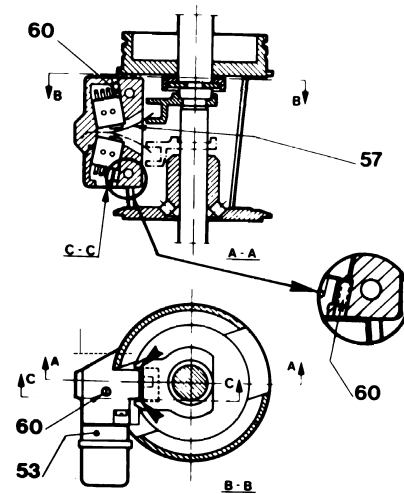

2

Pre-use check:

1. Supply compressed air to the actuator.
2. Open and close the valve several times to ensure that it operates smoothly.

Pay special attention to the warnings!

Recycling information.

• Unpacking

- Packing material consists of wood, plastics, cardboard boxes and in some cases metal straps.
- Wood and cardboard boxes can be reused, recycled or used for energy recovery.
- Plastics should be recycled or burnt at a licensed waste incineration plant.
- Metal straps should be sent for material recycling.

• Maintenance

- During maintenance oil and wear parts in the machine are replaced.
- All metal parts should be sent for material recycling.
- Worn out or defective electronic parts should be sent to a licensed handler for material recycling.
- Oil and all non metal wear parts must be taken care of in agreement with local regulations.

• Scrapping

- At end of use, the equipment shall be recycled according to relevant, local regulations. Beside the equipment itself, any hazardous residues from the process liquid must be considered and dealt with in a proper manner. When in doubt, or in the absence of local regulations, please contact the local Alfa Laval sales company.

Study the instructions carefully and pay special attention to the warnings!
Ensure that the valve operates smoothly.

The items refer to the drawings and the parts list on pages 24-31.

1. Operation

1



- **Always** observe the technical data (see page 22).
- **Always** release compressed air after use.

NOTE!

We cannot be held responsible for incorrect operation.

2

Burning danger!

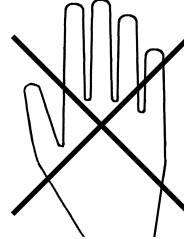

Never touch the valve or the pipelines when processing hot liquids or when sterilizing.

3

Moving parts!

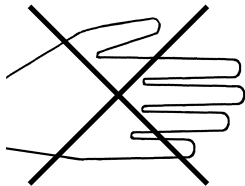

Never touch the clip assembly or the actuator piston rod if the actuator is supplied with compressed air.

4

CAUTION!

It is recommended **not** to re-use diaphragm (20b) after dismantling (risk of damage and leakage).

5

NOTE!

It is recommended **not** to use the valve under vacuum as there will be no visual leakage indication.

6

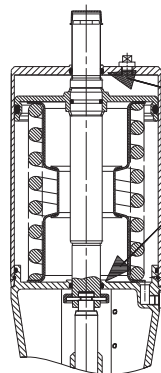

Lubricate if necessary!
(see page 15)

TD 425-054

Lubrication of actuator

1. Ensure smooth movement of the actuator (the actuator is lubricated before delivery).
2. Lubricate with oil/grease if necessary.

Pay attention to possible faults.

Study the instructions carefully.
The items refer to the drawings and the parts list on pages 24-31.

2. Fault finding

12

NOTE!

Study the maintenance instructions carefully before replacing worn parts. - See page 14!

Problem	Cause/result	Repair
The valve plug jerks	The seals seize	Lubricate: - O-rings (2) - O-ring (6) and the inside of cylinder (3)
Product leakage at stem and/or clamp	Worn/product affected diaphragm stem seal and/or seal ring (17)	- Replace the seals - Select a different rubber grade
Product leakage (closed valve)	- Worn/product affected plug seal ring - Loose plug parts (vibrations) - Product deposits on the seat and/or plug	- Replace the seal ring - Select a different rubber grade - Tighten the loose parts - Frequent cleaning
Product leakage (too high pressure or too small actuator)	- Worn actuator O-rings - Too small actuator or actuator spring	- Replace the O-rings - Select a larger actuator (for valve sizes 38 - 63.5 mm (1½" - 2½")) - Fit a stronger spring - Use auxiliary air on the spring side (NOT-element)
Water hammer	The flow direction is the same as the closing direction	- The flow direction should be against the closing direction - Fit a damper on the valve (optional extra) - Use auxiliary air on the spring side (NOT-element)
The valve does not open/close	- Faulty clip assembly (11) - The pressure on the plug is too high	- Replace the clip assembly - Reduce the pressure - Fit stronger spring/larger actuator

The valve is designed for cleaning in place (CIP).
CIP = Cleaning In Place.

Study the instructions carefully and pay special attention to the warnings!

NaOH = Caustic Soda.

HNO₃ = Nitric acid.

3. Recommended cleaning

1

Caustic danger!



Always use rubber gloves!



Always use protective goggles!



Always handle lye and acid with great care.

3

Clean the plug and the seats correctly.

- Stop valve: Open it.
- Change-over valve: Lift and lower momentarily (flip).

Pay special attention to the warnings!

5

1. Avoid excessive concentration of the cleaning agent
⇒ **Dose gradually!**
2. Adjust the cleaning flow to the process
⇒ **Milk sterilization/viscous liquids**
⇒ **Increase the cleaning flow!**
3. **Always** rinse well with clean water after the cleaning.

2

Burning danger!

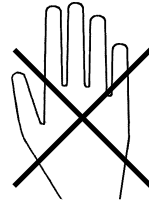

Never touch the valve or the pipelines when sterilizing.

4

Examples of cleaning agents:

Use clean water, free from chlorides.

1. 1% by weight NaOH at 70°C.

1 kg NaOH	+	100 l water	= Cleaning agent.
--------------	---	----------------	-------------------

2.2 l 33% NaOH	+	100 l water	= Cleaning agent.
-------------------	---	----------------	-------------------

2. 0.5% by weight HNO₃ at 70°C.

0.7 l 53% HNO ₃	+	100 l water	= Cleaning agent.
-------------------------------	---	----------------	-------------------

6

NOTE!

The cleaning agents must be stored/discharged in accordance with current rules/directives.

Maintain the valve carefully.
Study the instructions carefully and pay special attention to the warnings!

Always keep spare rubber seals and diaphragms in stock.

1. General maintenance

1



- **Always** observe the technical data (see page 22).
- **Always** release compressed air after use.

NOTE!

All scrap must be stored/discharged in accordance with current rules/directives.

2

Burning danger!

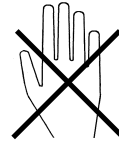

Atmospheric pressure required!



- The valve must **never** be hot when serviced.
- The valve and the pipelines must **never** be pressurised when the valve is serviced.

3

Cutting danger!

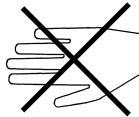

Never stick your fingers through the valve ports if the actuator is supplied with compressed air.

4

Moving parts!

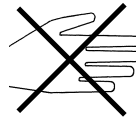

Never touch the clip assembly or the actuator piston rod if the actuator is supplied with compressed air.

Ordering spare parts

- Contact the Sales Department.
- Order from the Spare Parts List.

Recommended spare parts: Service kits (see Spare Parts List).

Maintain the valve carefully.
Study the instructions carefully.

Always keep spare rubber seals and diaphragms in stock.
Check the valve for smooth operation after service.

1. General maintenance

	Valve diaphragm unit	Valve rubber seals	Actuator rubber seals
Preventive maintenance	Replace after 12 months (depending on working conditions)	Replace when replacing the diaphragms	Replace after 5 years
Maintenance after leakage (leakage normally starts slowly)	Replace at the end of the day	Replace when replacing the diaphragms	Replace when possible
Planned maintenance	<ul style="list-style-type: none"> - Regular inspection for leakage and smooth operation - Keep a record of the valve - Use the statistics for planning of inspections Replace after leakage	Replace when replacing the diaphragms	<ul style="list-style-type: none"> - Regular inspection for leakage and smooth operation - Keep a record of the actuator - Use the statistics for planning of inspections Replace after air leakage
Lubrication (USDA H1 approved oil/grease)	Before fitting Silicone oil or silicone grease	Before fitting Silicone oil or silicone grease	Before fitting Oil or grease

Pre-use check:

1. Supply compressed air to the actuator.
2. Open and close the valve several times to ensure that it operates smoothly.

Pay special attention to the warnings!

Maintenance

16

*Study the instructions carefully.
The items refer to the drawings and the parts list on
pages 24-31.*

*Handle scrap correctly.
NC = Normally closed.
NO = Normally open.
A/A = Air/air activated.*

2. Dismantling of valve

1

NC actuator:

1. Remove clip assembly (11).
2. Supply compressed air to the actuator.
3. Remove upper clamp (15).
4. Remove the actuator.
5. Release compressed air.

Pay special attention to the warnings!

3

1. Remove clamp (15).
2. Remove intermediate ring (13).

5

1. Remove the complete diaphragm/stem unit from valve body (16 or 18).
2. For valve sizes 76-101.6 mm and DN80-100 the unit is removed from diaphragm ring (21).

2

NO actuator:

1. Remove upper clamp (15).
2. Supply compressed air to the actuator.
3. Remove clip assembly (11).
3. Remove the actuator.
5. Release compressed air.

Pay special attention to the warnings!

4

Change-over valve:

1. Remove lower clamp (15).
2. Dismantle upper and lower valve bodies (16, 18).
3. Remove lower seal ring (17).

6

Stop valve:

1. Remove diaphragm ring (21) and seal ring (17), (only for valve sizes 76-101.6 mm and DN80-100).
2. Remove washer (14) from upper stem (19).

Study the instructions carefully.
The items refer to the drawings and the parts list on pages 24-31.

Handle scrap correctly.
NC = Normally closed.
NO = Normally open.
A/A = Air/air activated.

2. Dismantling of valve

7

Turn upper stem (19) anticlockwise and remove it from lower stem (22a), (counterhold with a spanner).

9

Change-over valve:

1. Remove diaphragm ring (21) and upper seal ring (17), (only for valve sizes 76-101.6 mm and DN80-100).
2. Remove lower stem (22a) from upper valve body (16).

11

Stop valve:

1. Remove screw (22g), O-ring (22f) and washer (22e) from lower stem (22a).
2. Remove seal (22d or 22h) from the stem.

8

1. Remove diaphragm (20a), diaphragm (20b) and stem seal (20d) from lower stem (22a).
2. Remove L-seal (20c) from diaphragm (20b).

10

Change-over valve:

1. Remove screw (22g), O-ring (22f) and washer (22e) from lower stem (22a).
2. Remove seal (22d or 22h), middle piece (22c) and seal (22b or 22h) from the stem.

Maintenance

18

Study the instructions carefully.
The items refer to the drawings and the parts list on pages 24-31.

Lubricate the rubber seals and the diaphragms before fitting them.

3. Assembly of valve

1

Stop valve:

1. Fit seal (22d or 22h) on lower stem (22a).
2. Fit washer (22e), O-ring (22f) and screw (22g) on the stem (use Loctite 243 or similar!).

2

Change-over valve:

1. Fit seal (22b or 22h), middle piece (22c) and seal (22d or 22h) on lower stem (22a).
2. Fit washer (22e), O-ring (22f) and screw (22g) on the stem (use Loctite 243 or similar!).

3

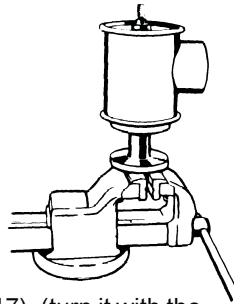

Change-over valve:

1. Fit upper seal ring (17), (turn it with the diagonal surface upwards!) and diaphragm ring (21) on the top of the upper valve body (only for valve sizes 76-101.6 mm and DN80-100).
2. Fit lower stem (22a) in upper valve body (16) so that the stem flange contacts the bottom of the valve body.

4



1. Fit lower stem (22a) through diaphragm ring (21), (only stop valve).
2. Fit L-seal (20c) on diaphragm (20b).
3. Fit stem seal (20d), diaphragm (20b) and diaphragm (20a) on lower stem (22a).

5



1. Apply Loctite 243 or similar on the thread of lower stem (22a).
2. Fit upper stem (19) on the lower stem, turn it clockwise and tighten until there is metallic contact between the upper and lower stems (counterhold with a spanner!).

6

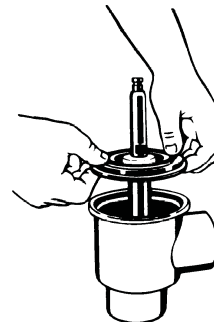

Stop valve:

1. Fit washer (14) on upper stem (19).
2. Fit seal ring (17), (turn it with the diagonal surface upwards!) and diaphragm ring (21) together with stem unit (22a) on the top of valve body (18), (only for valve sizes 76-101.6 mm and DN80-100).

Study the instructions carefully.
The items refer to the drawings and the parts list on pages 24-31.

Lubricate the rubber seals and the diaphragms before fitting them.

3. Assembly of valve

7

Correct!

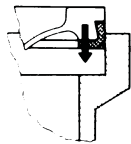

Wrong!

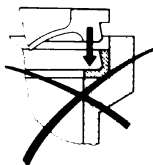

1. Fit the complete diaphragm/stem unit in valve body (16 or 18).
2. For valve sizes 76-101.6 mm and DN80-100 the unit is fitted in diaphragm ring (21).

NOTE!

Ensure that L-seal (20c) is fitted on diaphragm (20b) before placing the diaphragm unit in the valve body.

9

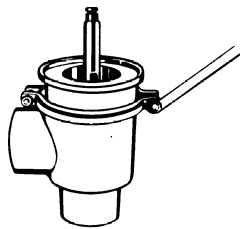

1. Fit intermediate ring (13) on valve body (16 or 18).
2. Fit and tighten clamp (15).

11

NC actuator:

1. Supply compressed air to the actuator.
2. Fit the plastic ring of clip assembly (11) on the actuator piston rod.
3. Fit the actuator on valve body (16 or 18) so that upper stem (19) enters the actuator piston rod.
4. Fit and tighten upper clamp (15).
5. Release compressed air.
6. Fit and assemble clip assembly (11).

Pay special attention to the warnings!

8

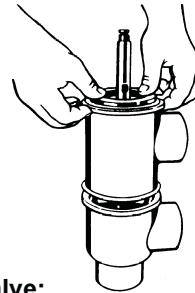

Change-over valve:

1. Fit lower seal ring (17), (Turn it with the diagonal surface upwards!) in lower valve body (18).
2. Fit upper valve body (16) and the complete diaphragm/stem unit together with the lower valve body.
3. Fit and tighten lower clamp (15).

10

NO actuator:

1. Fit the plastic ring of clip assembly (11) on the actuator piston rod.
2. Supply compressed air to the actuator.
3. Fit the actuator on valve body (16 or 18) so that upper stem (19) enters the actuator piston rod.
4. Fit and assemble clip assembly (11).
5. Release compressed air.
6. Fit and tighten upper clamp (15).

Pay special attention to the warnings!

Maintenance

20

Study the instructions carefully.
The items refer to the drawings and the parts list on pages 24-31.

Handle scrap correctly.
A/A = Air/air activated.

4. Dismantling of actuator

1

Turn with the
service tool!

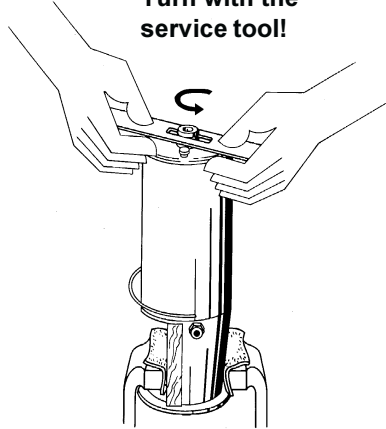

1. Turn cylinder (3).
2. Remove lock wire (4).

2

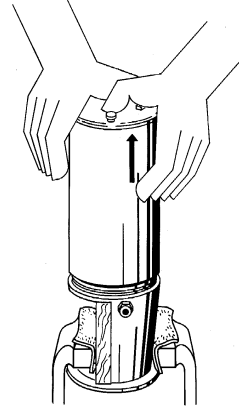

1. Remove cylinder (3).
2. Remove O-rings (2, 7) from bonnet (8).

3

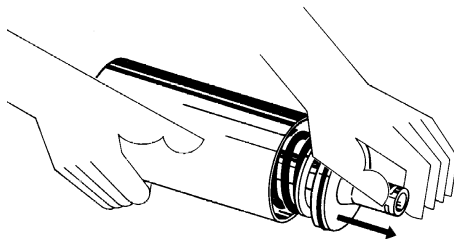

1. Remove piston (6) and spring assembly (10).
2. Remove O-ring (5) from the piston.
3. Remove O-ring (2) from cylinder (3).

NOTE!

The A/A actuator has no spring assembly.

4

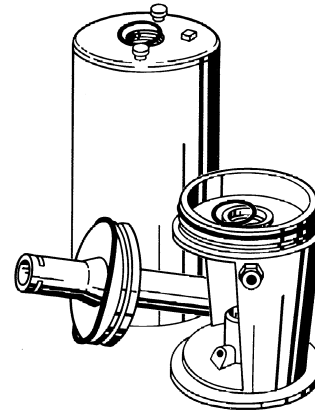

Replace the rubber seals.

Study the instructions carefully.
The items refer to the drawings and the parts list on pages 24-31.
Lubricate the rubber seals before fitting them.

5. Assembly of actuator

1

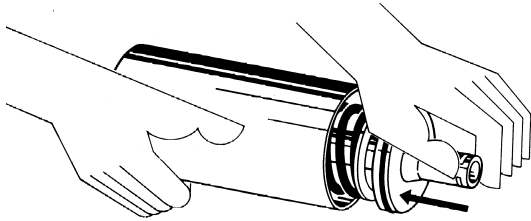

1. Fit O-ring (2) in cylinder (3).
2. Fit O-ring (5) on piston (6).
3. Fit the piston and spring assembly (10).

NOTE!

The A/A actuator has no spring assembly.

2

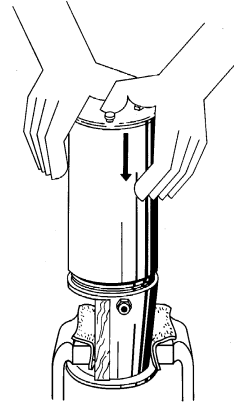

1. Fit O-rings (2, 7) in bonnet (8).
2. Fit cylinder (3).

3

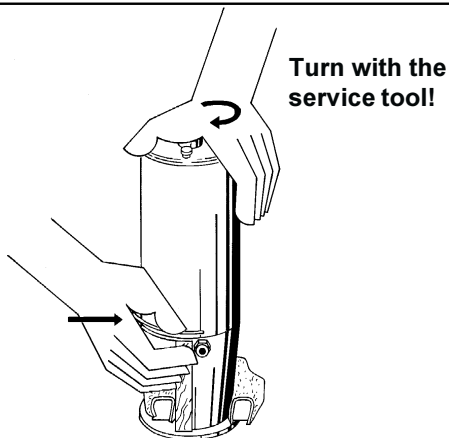

1. Fit lock wire (4) through the slot in cylinder (3) into the hole in bonnet (8).
2. Turn the cylinder 360° (see 4).

4

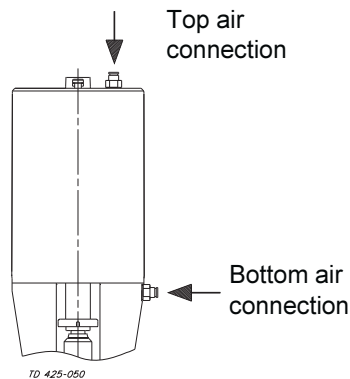

NOTE!

It is recommended to turn cylinder (3) further 180° in relation to bonnet (8) so that the top and bottom air connections are fixed on the same side.

Technical data

22

It is important to observe the technical data during installation, operation and maintenance.

*Inform the personnel about the technical data.
NO = Normally open.
NC = Normally closed.*

1. Technical data

Technical data

Pressure range	0 - 800 kPa (0-8 bar)
Temperature range	-10°C to 140°C (EPDM)
Optimum process conditions	>50 kPa (0,5 bar), > 20°C
Max. sterilisation temperature (steam – short time) ...	150°C – 380kPa (3,8 bar)
Air pressure	500 – 800 kPa (5-8 bar)
Air consumption (litres free air)	
38mm, 51mm, DN40, DN50	0,2 x air pressure in bar
63,5mm, 76mm, 101,6mm, DN65, DN 80, DN100	0,7 x air pressure in bar

NOTE! Vacuum is not recommended in aseptic applications.

Expected lifetime of diaphragm unit under normal conditions: (no pressure shocks or cavitation)		
Size\Type	Stop valve activations	Change over valve activations
38mm/DN40	25.000	10.000
51mm/DN50	25.000	10.000
63,5mm/DN65	25.000	5.000
76,1mm/DN80	5.000	5.000
101mm/DN100	5.000	5.000

NOTE! Activating the valve without internal product pressure reduces lifetime of diaphragm unit.

Materials

Product wetted steel parts	Acid resistant steel AISI 316L
Other steel parts	Stainless steel AISI 304
Finish	Semi bright
Product wetted seals	EPDM, PTFE
Other seals	NBR, EPDM

Noise

One meter away from - and 1.6 meter above the exhaust the noise level of a valve actuator will be approximately 77db(A) without noise damper and approximately 72 db(A) with damper - Measured at 7 bars air-pressure.



Drawing/Parts list

The drawings and the parts list include all items.
 NO = Normally open.
 NC = Normally closed.

The items are identical with the items in the Spare Parts List.
 When ordering spare parts, please use the Spare Parts List!

Parts list ARC - stop valve

24

Item	Qty.	Denomination
1	1	Cap
2Δ	2	O-ring
3	1	Cylinder
4Δ	1	Lock wire
5Δ	1	O-ring
6	1	Piston
7Δ	1	O-ring
8	1	Bonnet
9	2	Plug
10◆	1	Spring assembly (Standard, black) Extra strong spring (alternative, white)
11Δ	1	Clip, complete
12	1	Drain tube
13	1	Intermediate piece
14	1	Washer
15	1	Clamp and screws
16	1	Valve body, upper
17Δ	1	Seal ring (stop valve)
	2	Seal ring (change-over valve)
18	1	Valve body, lower
19	1	Stem, upper
20Δ	1	Diaphragm set
20a	1	Diaphragm support
20b	1	Diaphragm
20c	1	L-seal
20d	1	Stem seal
21	1	Diaphragm ring
22		Plug, single, compl.
a	1	Stem, lower
b Δ	1	Seal
c	1	Middle piece
d Δ	1	Seal
e	1	Washer
f Δ	1	O-ring
g	1	Screw
h Δ	1	O-ring
i Δ	1	O-ring

Δ : Service kit - EPDM, NBR, FPM
 (See Spare Parts List)

◆ : Only for NO- and NC actuators

This page shows an exploded drawing of ARC, stop valve.

The drawing includes all items of the valve. They are identical with the items in the Spare Parts List

Exploded drawing

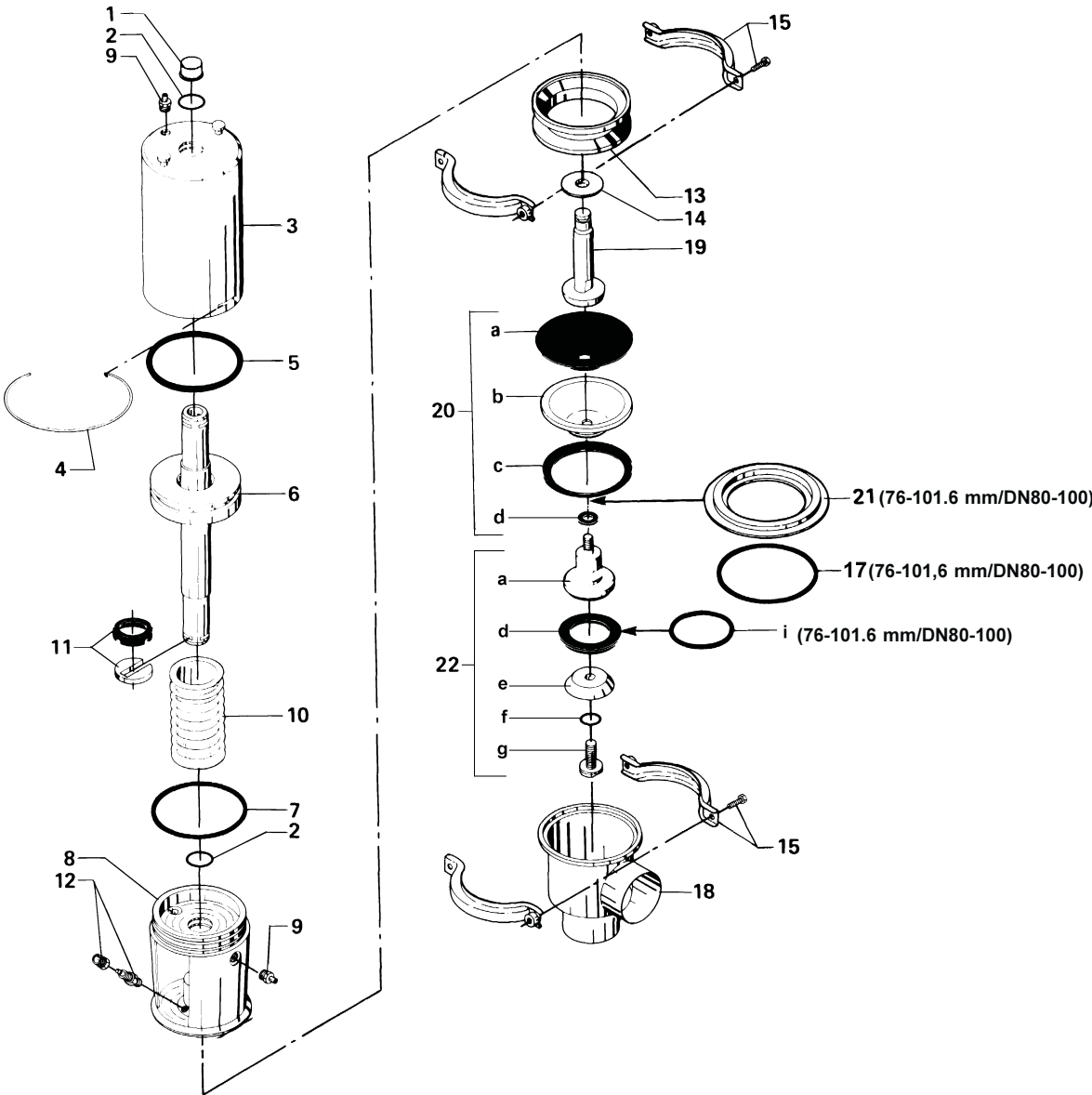

Drawing/Parts list

The drawings and the parts list include all items.
 NO = Normally open.
 NC = Normally closed.

The items are identical with the items in the Spare
 Parts List.
 When ordering spare parts, please use the Spare
 Parts List!

Parts list ARC - change-over valve

26

Item	Qty.	Denomination
1	1	Cap
2Δ	2	O-ring
3	1	Cylinder
4Δ	1	Lock wire
5Δ	1	O-ring
6	1	Piston
7Δ	1	O-ring
8	1	Bonnet
9	2	Plug
10◆	1	Spring assembly (Standard, black) Extra strong spring (alternative, white)
11Δ	1	Clip, complete
12	1	Drain tube
13	1	Intermediate piece
14	1	Washer
15	1	Clamp and screws
16	1	Valve body, upper
17Δ	1	Seal ring (stop valve)
	2	Seal ring (change-over valve)
18	1	Valve body, lower
19	1	Stem, upper
20Δ	1	Diaphragm set
20a	1	Diaphragm support
20b	1	Diaphragm
20c	1	L-seal
20d	1	Stem seal
21	1	Diaphragm ring
22		Plug, single, compl.
a	1	Stem, lower
b Δ	1	Seal
c	1	Middle piece
d Δ	1	Seal
e	1	Washer
f Δ	1	O-ring
g	1	Screw
h Δ	1	O-ring
i Δ	1	O-ring

Δ : Service kit - EPDM, NBR, FPM
 (See Spare Parts List)

◆ : Only for NO- and NC actuators

This page shows an exploded drawing of ARC, change-over valve.

The drawing includes all items of the valve. They are identical with the items in the Spare Parts List.

Exploded drawing

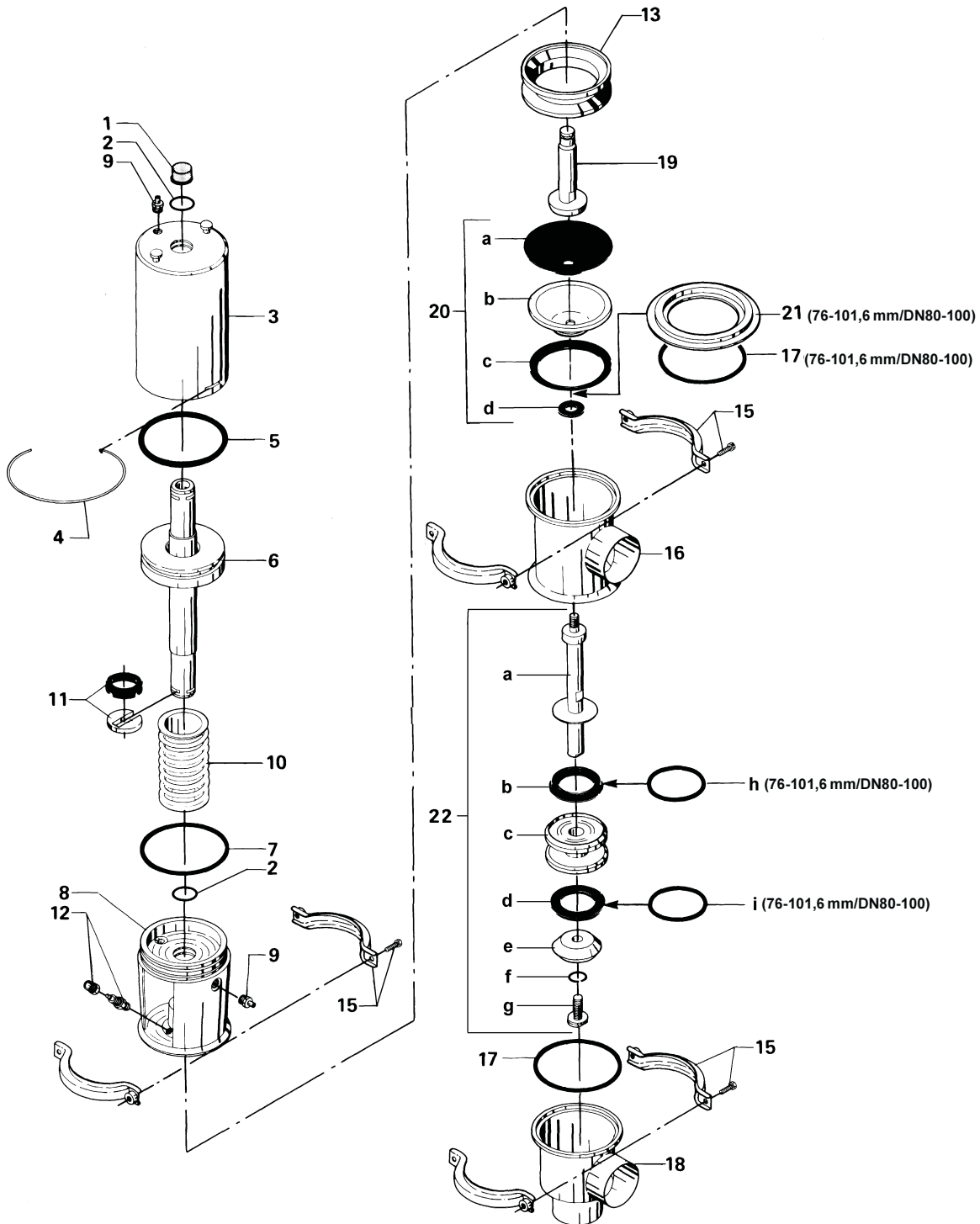

Drawing/Parts list

The drawings and the parts list include all items.
 NO = Normally open.
 NC = Normally closed.

The items are identical with the items in the Spare Parts List.
 When ordering spare parts, please use the Spare Parts List!

Parts list ARC

28

Item	Qty.	Denomination
1	1	Cap
2Δ	2	O-ring
3	1	Cylinder
4Δ	1	Lock wire
5Δ	1	O-ring
6	1	Piston
7Δ	1	O-ring
8	1	Bonnet
9	2	Plug
10◆	1	Spring assembly (Standard, black) Extra strong spring (alternative, white)
11Δ	1	Clip, complete
12	1	Drain tube
13	1	Intermediate piece
15	1	Clamp and screws
16	1	Valve body, upper
17Δ	1	Seal ring (stop valve)
	2	Seal ring (change-over valve)
18	1	Valve body, lower
19	1	Stem, upper
20Δ	1	Diaphragm set
20a	1	Diaphragm support
20b	1	Diaphragm
20c	1	L-seal
20d	1	Stem seal
21	1	Diaphragm ring
22		Plug, single, compl.
a	1	Stem, lower
b Δ	1	Seal
c	1	Middle piece
d Δ	1	Seal
e	1	Washer
f Δ	1	O-ring
g	1	Screw
h Δ	1	O-ring
i Δ	1	O-ring

Δ : Service kit - EPDM, NBR, FPM
 (See Spare Parts List)

◆ : Only for NO- and NC actuators

The drawings below show ARC, stop valve and change-over valve.

The items refer to the parts list on the opposite part of the page.

Drawings

Stop valve

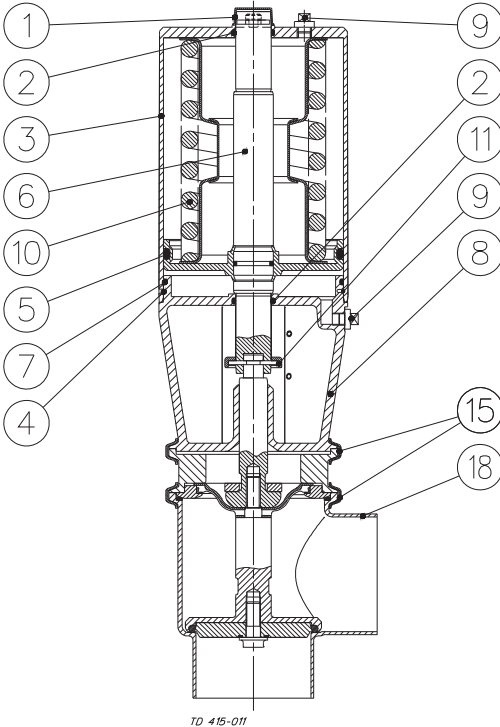

Change-over valve

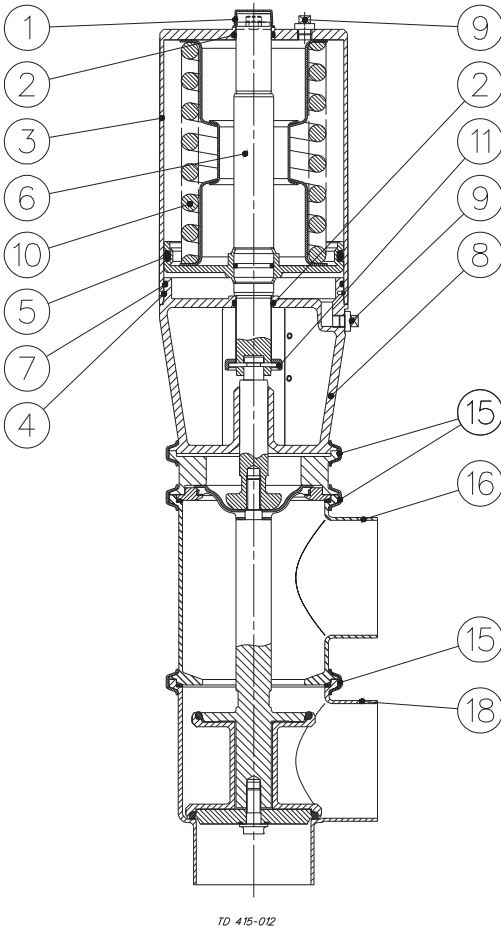

Drawing/Parts list

The drawings and the parts list include all items.
 NO = Normally open.
 NC = Normally closed.

The items are identical with the items in the Spare Parts List.
 When ordering spare parts, please use the Spare Parts List!

Parts list ARC

30

Item	Qty.	Denomination
1	1	Cap
2Δ	2	O-ring
3	1	Cylinder
4Δ	1	Lock wire
5Δ	1	O-ring
6	1	Piston
7Δ	1	O-ring
8	1	Bonnet
9	2	Plug
10◆	1	Spring assembly (Standard, black) Extra strong spring (alternative, white)
11Δ	1	Clip, complete
12	1	Drain tube
13	1	Intermediate piece
14	1	Washer
15	1	Clamp and screws
16	1	Valve body, upper
17Δ	1	Seal ring (stop valve)
	2	Seal ring (change-over valve)
18	1	Valve body, lower
19	1	Stem, upper
20Δ	1	Diaphragm set
20a	1	Diaphragm support
20b	1	Diaphragm
20c	1	L-seal
20d	1	Stem seal
21	1	Diaphragm ring
22		Plug, single, compl.
a	1	Stem, lower
b Δ	1	Seal
c	1	Middle piece
d Δ	1	Seal
e	1	Washer
f Δ	1	O-ring
g	1	Screw
h Δ	1	O-ring
i Δ	1	O-ring

Δ : Service kit - EPDM, NBR, FPM
 (See Spare Parts List)

◆ : Only for NO- and NC actuators

The drawings below show ARC, stop valve and change-over valve.

The items refer to the parts list on the opposite part of the page.

Drawings

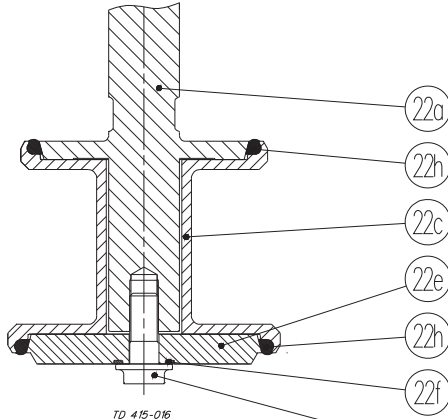
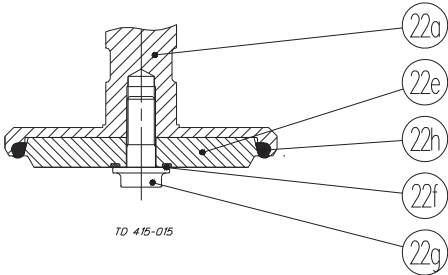
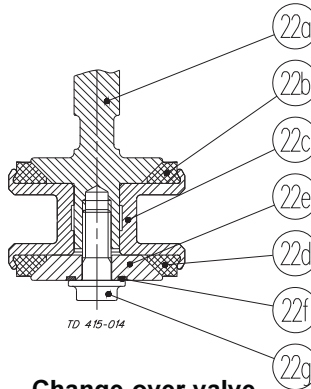
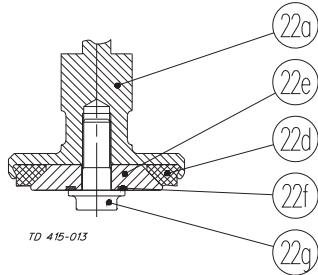
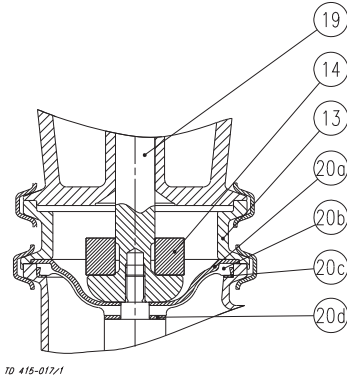
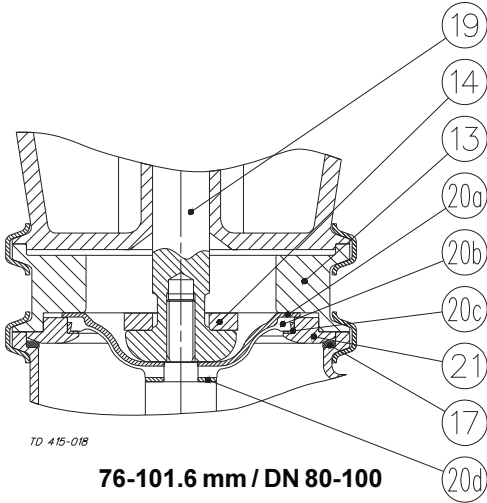

Drawing/Parts list

The drawings and the parts list include all items.
NO = Normally open.
NC = Normally closed.

The items are identical with the items in the Spare Parts List.
When ordering spare parts, please use the Spare Parts List!

Parts list Oil damper for ARC (optional extra)

32

Item	Qty.	Denomination
70	1	Housing
71	1	Clip
72	1	Piston rod
73	1	O-ring
74	1	Spring
75	1	O-ring
76	6	Screw
77	6	Washer
78	1	O-ring
79	1	Circlip
80	1	Piston
81	1	Cover
82	1	Plug
83	1	O-ring
84	1	Protective hood
85	3	Screw
86	1	Spring
87	1	Nut
88	1	Screw

*This page shows an exploded drawing of the oil damper for ARC.
The damper is an optional extra.*

*The drawing includes all items of the valve.
They are identical with the items in the Spare Parts List.*

Exploded drawing

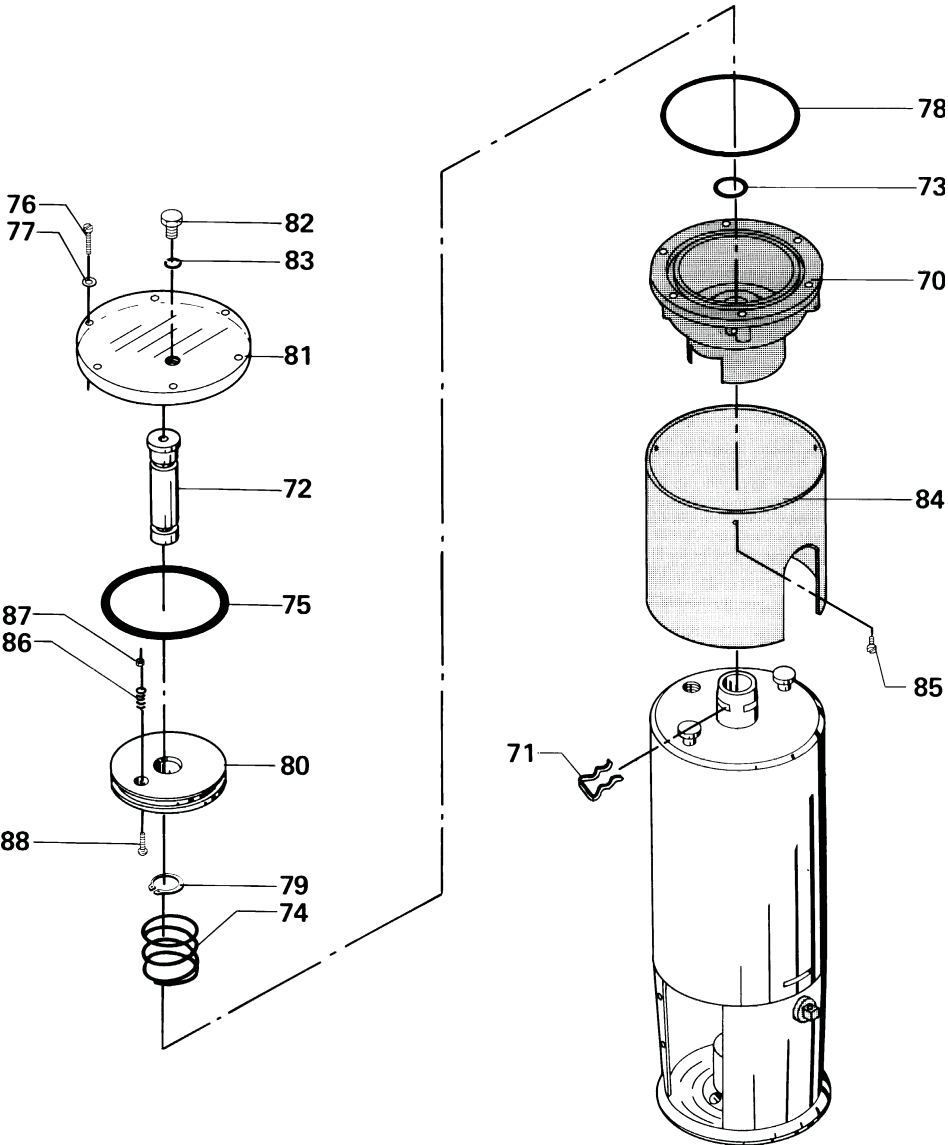

Drawing/Parts list

The drawings and the parts list include all items.
NO = Normally open.
NC = Normally closed.

The items are identical with the items in the Spare Parts List.
When ordering spare parts, please use the Spare Parts List!

Parts list Oil damper for ARC (optional extra)

34

Item	Qty.	Denomination
70	1	Housing
71	1	Clip
72	1	Piston rod
73	1	O-ring
74	1	Spring
75	1	O-ring
76	6	Screw
77	6	Washer
78	1	O-ring
79	1	Circlip
80	1	Piston
81	1	Cover
82	1	Plug
83	1	O-ring
84	1	Protective hood
85	3	Screw
86	1	Spring
87	1	Nut
88	1	Screw

The drawings below show the oil damper for ARC.
The damper is an optional extra.

The items refer to the parts list on the opposite part of
the page.

Drawings

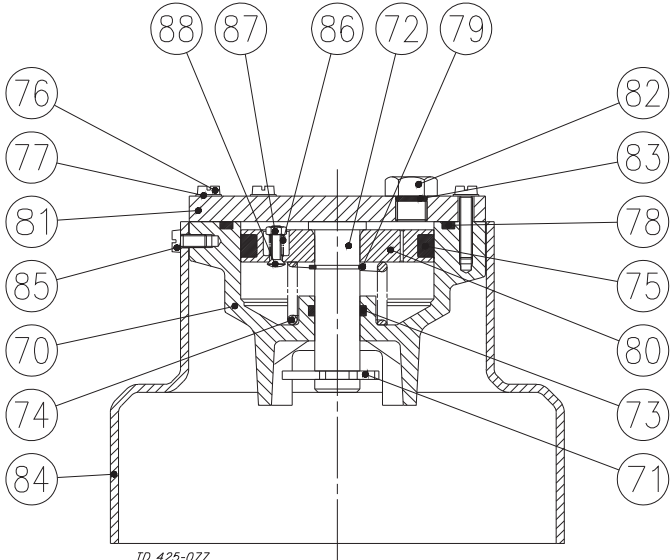

76-101.6 mm / DN 80-100

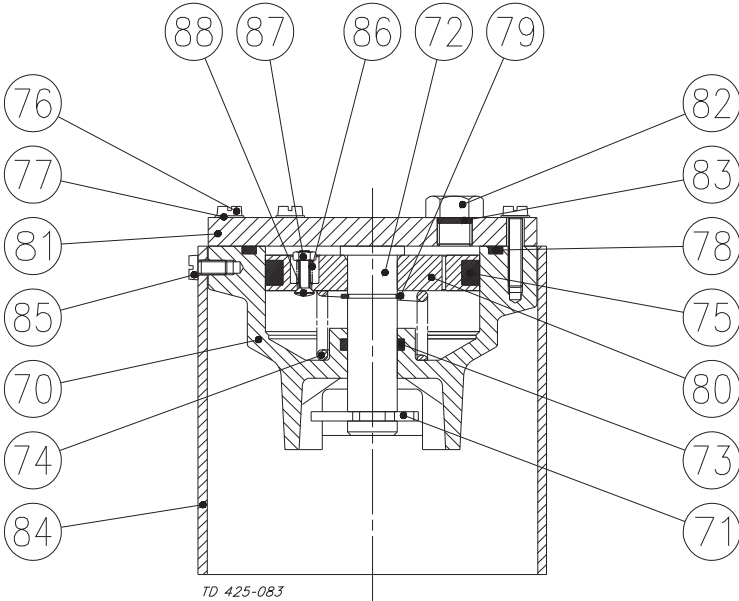

38-63.5 mm / DN 40-65

Drawing/Parts list

The parts list includes all items.

The items are identical with the items in the Spare Parts List.

When ordering spare parts, please use the Spare Parts List!

Parts list

Indication units for ARC (optional extra)

36

Item	Qty.	Denomination
51	1	Holder
53	1	Switch unit, 1 micro switch
	1	Switch unit, 2 micro switches
53♦	1	Switch unit complete with 2 switches
55	2	Screw
56	1	Ring
56♦	1	Ring (grey), change-over valve
	1	Ring (black), stop valve
57	1	Spring
58	2	Screw
58♦	2	Screw
59	1	Cable connector complete for 4.5-7mm cable
60	2	Adjustment

♦: Inductive proximity switch unit.

This page shows exploded drawings of the indication unit with micro switch or with inductive proximity switch.

*The indication unit is an optional extra.
The drawings include all items of the valve.
They are identical with the items in the Spare Parts List.*

Exploded drawing

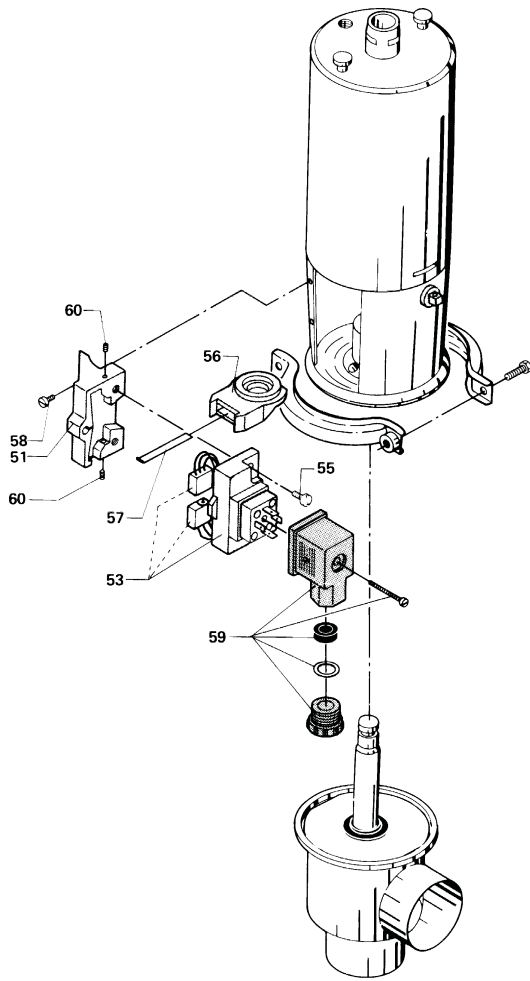

Micro switch unit

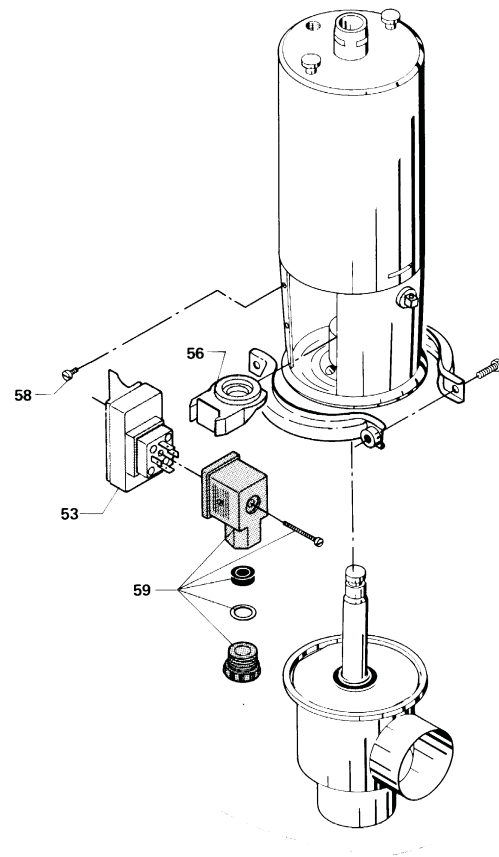

Proximity switch unit (◆)

How to contact Alfa Laval

Contact details for all countries are continually updated on our website. Please visit www.alfalaval.com to access the information direct.