

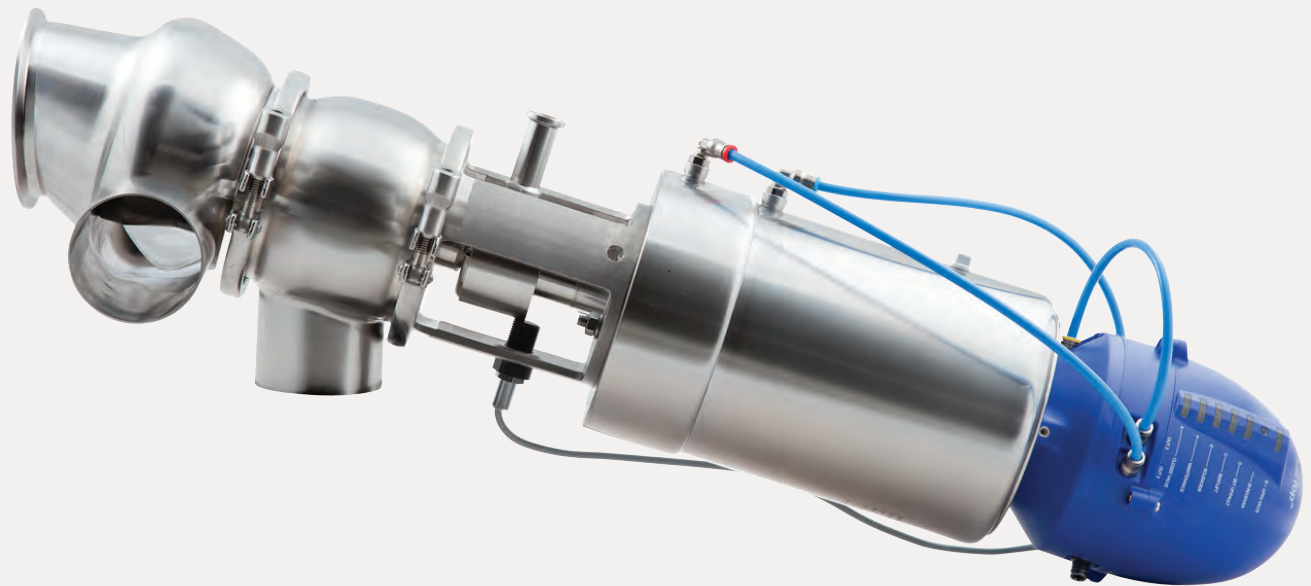

## Instruction Manual

**Unique PMO Plus CP HT Series** Sanitary Mixproof Valve  
Sizes 2½", 3", 4" & 6"

Effective 05/04/2012



ESE 02217 2012-05



# Table of Contents

---

The information contained herein is correct at the time of issue but may be subject to change without prior notice.

|                                      |                |
|--------------------------------------|----------------|
| Introduction .....                   | 4              |
| Safety .....                         | 5              |
| Installation .....                   | 6              |
| Specifications .....                 | 8              |
| Pneumatic Connections.....           | 10             |
| Position Indication .....            | 11             |
| Electrical Connections .....         | 12-1 thru 12-4 |
| ThinkTop.....                        | 13             |
| Cleaning Procedures .....            | 31             |
| Valve Seat Position Indication ..... | 35             |
| Maintenance.....                     | 41             |
| Parts List .....                     | 62             |

Thank you for purchasing an Alfa Laval product.

This manual has been provided to instruct you how to operate and service this product correctly and safely. Be sure to follow all directions and instructions; failure to do so could result in personal injury or equipment damage.

This manual should be considered part of this product and should remain with it at all times for reference. (If you sell it, please be sure to include this manual with it).

Warranty is provided as part of Alfa Laval's commitment to our customers who operate and maintain their equipment as this manual dictates. Failure to do so may result in loss of warranty.

Where defects appear on the product during the warranty period, Alfa Laval Inc. will back the product and correct the problem. Should the equipment be modified or not kept in the manner prescribed within this manual, the warranty will become null and void.

**Follow Safety Directions**

Read this manual thoroughly before working on equipment.

Leave all safety stickers on equipment and keep them maintained in legible condition. In the event that stickers become damaged or are missing, contact Alfa Laval for replacement.

Maintain equipment in good working condition.

**Do Not Make Machine Modifications**

Alfa Laval offers a full range of products to suit all your needs. Therefore, product modification is never necessary.

**Keep Maintenance Safe**

Replace damaged or worn parts immediately. Never allow old product, debris, or any lubricants to build up on equipment. Never operate unless equipment is in proper working order.

Before attempting to service the machine, disconnect all power and compressed air. Allow machine to come to a complete stop. Never service a machine while it is operating. Keep all limbs away from moving equipment. Be sure that product pressure has been relieved before beginning maintenance.

## Unpacking

The valves should be unpacked immediately upon receipt from the factory and carefully inspected for damage that may be occurred during shipping. The equipment should also be checked against the bill of lading to make sure there are no shortages. Any damage or shortage should be reported to the carrier.

## Locating

The valves are mounted directly into the product line. Care should be taken, however, to locate the valves in a place where they are easily reached for maintenance and disassembly.

## Installing

**Line Mounted Valve:** The valves may be installed in lines that are firmly supported and capable of carrying the valve's weight. Mount valves at an 15° angle, or as close as possible, ensuring that the angle is as least 15°. Furthermore Alfa Laval recommends that the valve is supported at the actuator.

Clearances required for removal of actuator/plug assembly for repair.

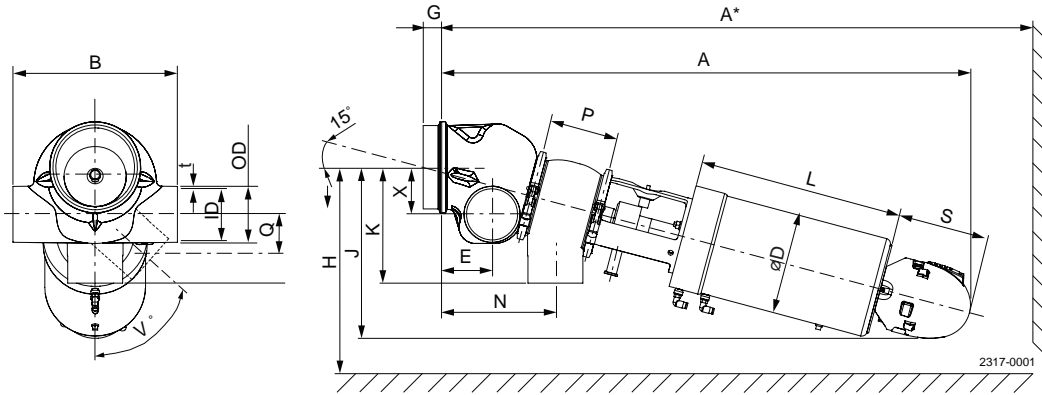

| Size           | 2.5"  | 3"    | 4"    | 6"<br>(2.95")<br>stroke | 6"<br>(2.32")<br>stroke |
|----------------|-------|-------|-------|-------------------------|-------------------------|
| A              | 28.94 | 29.88 | 38.46 | 42.83                   | 42.83                   |
| A*             | 34.13 | 35.59 | 45.47 | 52.32                   | 52.32                   |
| B              | 8.66  | 8.66  | 11.81 | 16.54                   | 16.54                   |
| OD             | 2.50  | 3.00  | 4.00  | 6.07                    | 6.07                    |
| ID             | 2.37  | 2.87  | 3.84  | 5.78                    | 5.78                    |
| t              | 0.06  | 0.06  | 0.08  | 0.14                    | 0.14                    |
| ØD             | 7.32  | 7.32  | 7.32  | 7.32                    | 7.32                    |
| E              | 2.79  | 3.04  | 3.63  | 5.10                    | 5.10                    |
| F1             | 1.50  | 1.50  | 2.95  | 2.95                    | 2.32                    |
| F2 (Tank plug) | 0.39  | 0.39  | 0.39  | 0.39                    | 0.39                    |
| G              | 0.63  | 0.63  | 1.50  | 1.75                    | 1.75                    |
| H              | 11.06 | 11.46 | 14.33 | 16.65                   | 16.65                   |
| J              | 9.69  | 9.92  | 12.48 | 14.13                   | 14.13                   |
| K              | 6.02  | 6.22  | 8.46  | 12.09                   | 12.09                   |
| L              | 9.92  | 9.92  | 14.92 | 14.92                   | 14.92                   |
| N              | 5.98  | 6.69  | 8.27  | 11.14                   | 11.14                   |
| P              | 3.52  | 4.01  | 4.98  | 7.09                    | 7.09                    |
| Q              | 0.63  | 0.63  | 1.50  | 1.75                    | 1.75                    |
| S              | 7.09  | 7.09  | 7.09  | 7.09                    | 7.09                    |
| V°             | 0-67° | 0-60° | 0-53° | 0-49°                   | 0-53°                   |
| X              | 1.51  | 1.44  | 2.07  | 3.69                    | 3.69                    |
| M/Tri-Clamp®   | 0.83  | 0.83  | 0.83  | 1.52                    | 1.52                    |

\*Includes ThinkTop®

It is important to observe the specification data during installation, operation and maintenance.

| Valve size   | 2", 2½" & 3" | 4"   | 6"   |      |
|--|--------------|------|------|------|
| Stroke length (inch)                                       | 1.50         | 2.95 | 1.97 | 2.95 |
| Product pressures (PSI)                                    |              |      |      |      |
| Maximum product pressure valve body                        | 145          | 145  | 145  | 145  |
| Maximum product pressure tank                              | 86           | 87   | 38   | 28   |
| Maximum product pressure valve body - Seat lift upper plug | 145          | 145  | 145  | 145  |
| Maximum product pressure tank - Seat lift tank plug        | 77           | 90   | 27   | 27   |

Min. Process Pressure

Full Vacuum

Max. Air Pressure

116 PSI — All Sizes

Min. Air Pressure

80 PSI

Temperature Range

23°F to 257°F

**Materials**

Product wetted steel parts: Acid-resistant steel AISI 316L

Other steel parts: Stainless steel AISI 304/304L

Product wetted parts: NBR, HNBR, EPDM or FPM

Other Seals: CIP Seals: EPDM  
Actuator seals: NBR

Finish: int./ext. Polished Ra<32

**Note: The Ra-values are only for the internal surfaces.**



**CIP solution flows for seat lift**

(viscosity and density similar to water)

| <b>CV Values</b>             |          |      |       |
|------------------------------|----------|------|-------|
| <b>Unique PMO Plus CP HT</b> |          |      |       |
|                              | 2½" & 3" | 4"   | 6"    |
| Upper seat lift              | 2.6      | 5.3  | 12.1  |
| Tank plug push               | 30       | 58.3 | 137.2 |

The following formula is used to estimate CIP flow during seat lifts:

$$Q = Cv \cdot (\sqrt{\Delta p})$$

Where: Q = Flow in USGPM

Cv = Value from table above

\*  $\Delta p$  = CIP pressure in PSI

**Valve Pneumatic Functions:**  
 Unique PMO Plus CP HT Valve Series

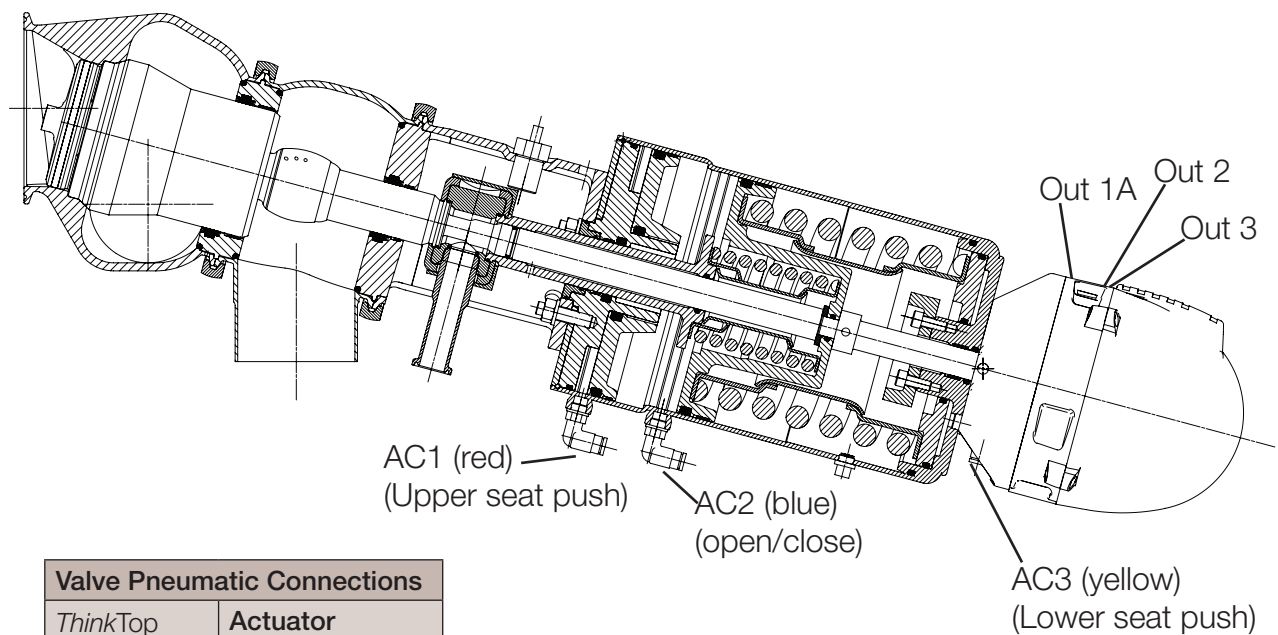

| Valve Pneumatic Connections |                     |
|-----------------------------|---------------------|
| ThinkTop Fitting ID         | Actuator Fitting ID |
| Out 1A                      | AC 2 (Blue)         |
| Out 2                       | AC 3 (Yellow)       |
| Out 3                       | AC 1 (Red)          |

**Valve Position Indication:**  
*Unique PMO Plus CP HT Series*

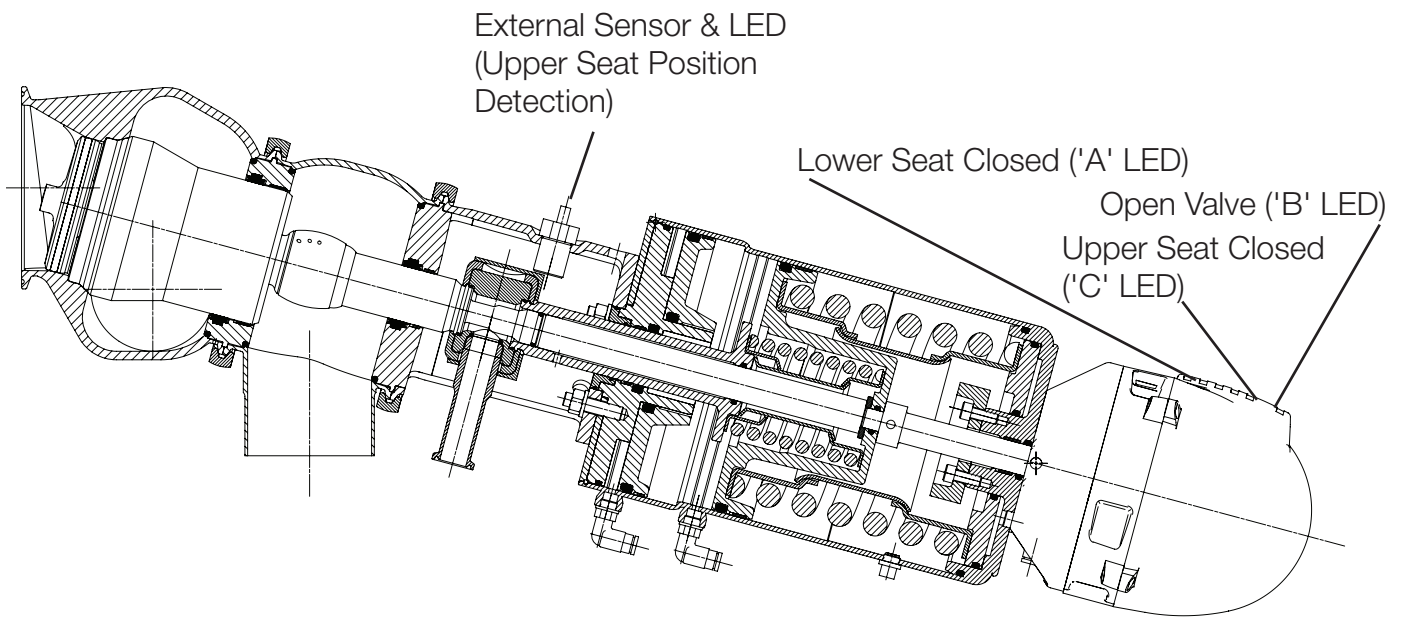

**Unique PMO Plus CP HT Valve Series Mixproof Valve**  
**ThinkTop® , 8-30 VDC #9612-5789-66 (0 Solenoid)**  
**Electrical Connection Chart**

| ThinkTop Term. No. | Function                      | Remarks                  |
|--------------------|-------------------------------|--------------------------|
| 9                  | +8-30 VDC                     | Power +                  |
| 10                 | -Common                       | Power -                  |
|                    | Ground                        | -----                    |
| 1                  | Closed Valve                  | PLC Input - Valve Closed |
| 2                  | Open Valve                    | PLC Input - Valve Open   |
| 3                  | Seat Lift - 1                 | PLC Input - Valve Closed |
| 5                  | Status                        | PLC Input - Optional     |
| 24                 | Seat Lift-1 (Upper) ( Signal) | External Sensor (WHT)    |
| 26                 | Supply +                      | External Sensor (BRN)    |
| 27                 | Supply -                      | External Sensor (BLU)    |
|                    | Not Used -                    | External Sensor (BLK)    |

**Unique PMO Plus CP HT Valve Series**  
**ThinkTop®**, 8-30 VDC #9612-5789-69 (3 Solenoids)  
**Electrical Connection Chart**

| ThinkTop Term. No. | Function                      | Remarks                  |
|--------------------|-------------------------------|--------------------------|
| 6                  | Solenoid - 1                  | Output - Valve Open      |
| 7                  | Solenoid - 2                  | Output - Lower Seat Push |
| 8                  | Solenoid - 3                  | Output - Upper Seat Lift |
| 9                  | +8-30 VDC                     | Power +                  |
| 10                 | -Common                       | Power - *(Jump to 11)    |
| 11                 | Solenoid Com.                 | Power - *(Jump to 10)    |
|                    | Ground                        | -----                    |
| 1                  | Closed Valve                  | PLC Input - Valve Closed |
| 2                  | Open Valve                    | PLC Input - Valve Open   |
| 3                  | Seat Lift - 1                 | PLC Input - Valve Closed |
| 5                  | Status                        | PLC Input - Optional     |
| 24                 | Seat Lift-1 (Upper) ( Signal) | External Sensor (WHT)    |
| 26                 | Supply +                      | External Sensor (BRN)    |
| 27                 | Supply -                      | External Sensor (BLU)    |
|                    | Not Used -                    | External Sensor (BLK)    |

\*One power supply, positive activation of solenoids.

**Unique PMO Plus CP HT Valve Series**  
**ThinkTop®**, 110 VAC #9612-9906-66 (0 Solenoid)  
**Electrical Connection Chart**

| ThinkTop Term. No. | Function                      | Remarks                           |
|--------------------|-------------------------------|-----------------------------------|
| 9                  | 110 VAC                       | Power +                           |
| 10                 | -Common                       | Power -                           |
|                    | Ground                        | -----                             |
| 1                  | Closed Valve                  | PLC Input - Valve Closed          |
| 2                  | Open Valve                    | PLC Input - Valve Open            |
| 3                  | Seat Lift - 1                 | PLC Input - Valve Closed          |
| 5                  | Status                        | PLC Input - Optional              |
| 24                 | Seat Lift-1 (Upper) ( Signal) | External Sensor (Red w/BLK rings) |
| 26                 | Supply +                      | External Sensor (Red w/WHT rings) |

**Unique PMO Plus CP HT Valve Series**  
**ThinkTop®, 110 VAC #9612-9906-69 (3 Solenoids)**  
**Electrical Connection Chart**

| ThinkTop Term. No. | Function                      | Remarks                           |
|--------------------|-------------------------------|-----------------------------------|
| 6                  | Solenoid - 1                  | Output - Valve Open               |
| 7                  | Solenoid - 2                  | Output - Lower Seat Push          |
| 8                  | Solenoid - 3                  | Output - Upper Seat Lift          |
| 9                  | 110 VAC                       | Power +                           |
| 10                 | -Common                       | Power - *(Jump to 11)             |
| 11                 | Solenoid Com.                 | Power - *(Jump to 10)             |
|                    | Ground                        | -----                             |
| 1                  | Closed Valve                  | PLC Input - Valve Closed          |
| 2                  | Open Valve                    | PLC Input - Valve Open            |
| 3                  | Seat Lift - 1                 | PLC Input - Valve Closed          |
| 5                  | Status                        | PLC Input - Optional              |
| 24                 | Seat Lift-1 (Upper) ( Signal) | External Sensor (Red w/BLK rings) |
| 26                 | Supply +                      | External Sensor (Red w/WHT rings) |
| 27                 | Supply -                      | External Sensor (BLU)             |
|                    | Not Used -                    | External Sensor (BLK)             |

\*One power supply, positive activation of solenoids.



# Instruction Manual

ThinkTop® Digital 8 - 30 VDC & 110 VAC PNP/NPN Used with **Unique PMO Plus CP HT**  
Series Mixproof Valves

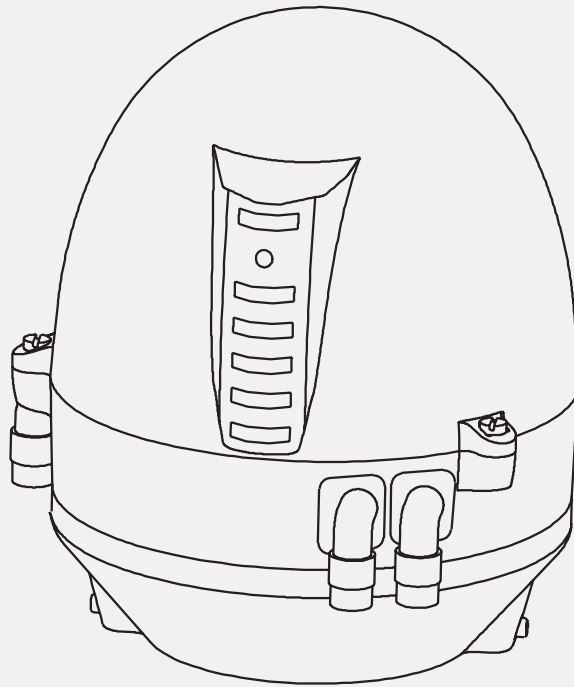

TD 800-006



## ThinkTop® Digital 8-30 or 110 VAC NO/NC

### Features

#### Tolerance

The tolerance band is  $\pm 1.5$  mm.

#### Built-In Maintenance Monitor

The unit can be preset to indicate when the time for maintenance of the valve has been reached. A status signal and flashing maintenance LED can be programmed to return after 3, 6, 9 or 12 months or more.

#### Other Features

Another very important fact is that the setup is kept until programmed otherwise even during failure in the power supply.

The accurate sensor system enables indication of seat lift to be integrated in the top unit.

#### Materials

|                |   |
|----------------|---|
| Plastic Parts: | Nylon PA 12.  |
| Steel part     | Stainless steel AISI 304 and 316.                     |
| Seals          | Nitrile (NBR). EPDM rubber for SMP-EC activator stem. |

#### Technical Data

|                     |                                    |
|---------------------|------------------------------------|
| Sensor accuracy:    | $\pm 0,1$ mm (0.0004 inch)         |
| Distance to magnet: | $5 \pm 3$ mm (0.12 $\pm$ 0.2 inch) |
| Stroke length:      | 0.1 - 80 mm (0.004 - 3.15 inch)    |

#### Electrical Connection

Direct cable gland entry (hard wired) PG11 ( $\varnothing 4$  -  $\varnothing 10$ mm) ( $\varnothing 0.16$  -  $\varnothing 0.39$  inch).

#### Terminals

The terminal row of the sensor unit is equipped with screw terminals for both internal as well as external cables and wires. The terminals are suitable for wires up to 0.75mm<sup>2</sup> (AWG19).

#### Power Supply - AC

The ThinkTop® is designed to be a part of the PLC's Input/Output (I/O) system. It should be supplied from the same protected power supply as the other I/O devices. The I/O power supply should not be used for other kinds of loads.

The unit is reversed polarity and short circuit protected. The power supply must meet the requirements of EN 61131-2.

|                              |  |
|------------------------------|--|
| Supply voltage:              | 8-30 or 100 - 126.5 VAC  |
| Supply voltage nominal:      | 24 or 110 VAC (+15%, -10%)<br>- pr. EN 61131-2   |
| Supply voltage absolute max: | 30 or 126.5 VAC  |
| Supply voltage absolute min: | 8 or 100 VAC   |
| Power consumption*):         | Max. 1.5 VA (8-30 VAC) or<br>max. 2.0 VA (110 VAC (for<br>sensor unit along) (Exclud-<br>ing current to the solenoids,<br>external proximity switches<br>and the PLC input current.) |

\*)The initial current during power-on is higher. Typical values are 440 mARCS during 10 ms (the first half cycle) followed by 270 ms at 2 x normal steady state current.

The fulfilling of the UL requirements in UL508 requires that the unit is supplied by an isolating source complying with the requirements for class 2 power units (UL1310) or class 2 and 3 transformers (UL 1585).

#### Feedback Signals

Output signals from the sensor unit to be connected digital interface (PLC).

|                  |   |
|------------------|---|
| Nominal voltage: | Must match the selected type of ThinkTop® |
| Load current:    | 50 mA Typical, 100 mA max.                |
| Voltage drop:    | Typical 3V at 50 mA                       |

#### External Sensors

The external sensors are used for seat-lift supervision when seat-lift cannot be internally detected. The sensors get their supply voltage from the terminal row. The output signals from the sensors are connected to two inputs on the terminal row on the internal sensor unit. If the actual setup is set for internal seat-lift, the corresponding external signal is not used, otherwise the external signal logically controls the corresponding feedback to the PLC.

|                 |  |
|-----------------|--|
| Supply voltage: | Must match the selected type of ThinkTop®. |
| Supply current: | Max. 15 mA per sensor.                     |
| Type of sensor: | 2 wire VAC (EN60947-5-2)                   |
| Cable length:   | Max. 3 m. (16.4 ft.)                       |

#### Polarity

NO or NC function is selected with a jumper between terminals 12 and 13. Jumper present = NO. If changing to NC remove the jumper and make a power recycle. A power recycle is always required when changing this function.

### ThinkTop® Digital 8-30 or 110 VAC NO/NC

#### Solenoid valves

Up to 3 solenoid valves in each unit.

|   |   |
|---|---|
| Type .....  | 3/2 or 5/2 valve (only with one 5/2 valve). |
| Air supply .....                                      | 300-900 kPa (3-9 bar) (43.5-130.5 PSI)      |
| Filtered air, max. particules or dirt.....            | 0.01 mm (0.0004 inch).                      |
| Max. oil content .....                                | 1.0 ppm.                                    |
| Max. water content.....                               | 0.0075 kg/kg air. (0.02 lb/lb)              |
| Throughput° .....                                     | Ø2.5mm                                      |
| Air restriction (throttle function) air inlet/outlet. |   |

Manual hold override.

|                                    |                                     |
|------------------------------------|-------------------------------------|
| External air tube connection ..... | Ø6 mm or ¼"                         |
| Silencer/filter*).....             | Connection possible via Ø6 mm or ¼" |
| Nominal voltage.....               | 24 or 110V                          |
| Nominal power .....                | 1.0 W.                              |

\*) Filter recommended in tropical regions.

#### Micro environment demand specifications

|                               |                                    |                        |
|-------------------------------|------------------------------------|------------------------|
| <b>Temperature</b>            |                                    |                        |
| Working:                      | -4°F to +185°F                     | IEC 68-2-1/2           |
| Storage:                      | -40°F to +185°F                    | IEC 68-2-1/2           |
| Temperature change:           | -13°F to +158°F                    | IEC 68-2-14            |
| <b>Vibration</b>              |                                    |                        |
| 10-55 Hz, 0.7 mm              | IEC 68-2-6                         |                        |
| 155-500 Hz, 10g               |                                    |                        |
| 3 x 30 min, 1 octave/min      |                                    |                        |
| <b>Drop test</b>              |                                    | IEC 68-2-32            |
| <b>Humidity</b>               |                                    |                        |
| Constant humidity             | +104°F, 21 days, 93% R.H.          | IEC 68-2-3             |
| Cyclic humidity:<br>(working) | +77°F/+131°F 12 cycles<br>93% R.H. | IEC 68-2-30            |
| <b>Protection class</b>       | IP67                               | IEC 529                |
| <b>Input treshold</b>         |                                    |                        |
| Voltage/current:              | Type 1 input requirements          | EN 61131-2             |
| <b>Solenoid signals</b>       |                                    |                        |
| Isolation voltage             | (1000 + 2 x 117) VAC rms/1 min     | EN 61131-2             |
| <b>EMC Directive</b>          | 89/336/EEC                         | EN 50081-1, EN 50082-2 |
| <b>UL/CSA Approval</b>        |                                    |                        |
|                               | 8-30 VAC                           | UL508-E203255          |
|                               | 110 VAC                            | UL 508-E223664         |

ThinkTop®. Digital 8-30 or 110 VAC NO/NC

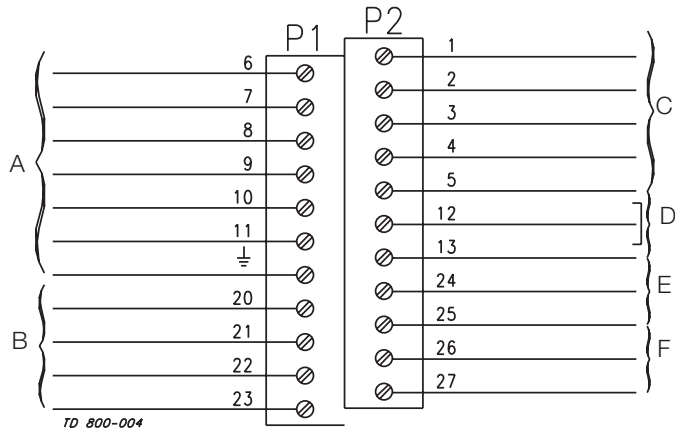

- A. Digital interface command signals
  - B. Internal connections to solenoid 1-3
  - C. Feedback signals to digital interface
  - D. Jumper connections \*\*)
  - E. Incoming signals from external sensors
  - F. Support to external sensors
- |                           |                             |
|---------------------------|-----------------------------|
| 6. Solenoid 1             | 1. Closed valve             |
| 7. Solenoid 2             | 2. Open valve               |
| 8. Solenoid 3             | 3. Seat-lift 1              |
| 9. Supply ~               | 4. Seat-lift 2              |
| 10. Supply ~              | 5. Status                   |
| 11. Solenoid common Earth | 12. NO/NC Jumper            |
| 20. Solenoid common Earth | 13. NO/NC Jumper            |
| 21. Solenoid 1            | 24. Seat-lift 1*) "upper" ~ |
| 22.                       | 25. Seat-lift 2*) "lower" ~ |
| 23.                       | 26. Supply ~ *) com. ~      |
|                           | 27. Earth                   |

\*) Note

- Terminals 24, 25, 26 and 27 can be used for external seat-lift sensors as well as for any digital input. Always use an external NO sensor.
- Two external signals can be connected, they are associated with feedback signals 3 (seat-lift 1) and 4 (seat-lift 2). External sensor must always be a 8-30 or 110 VAC NO 2 wire sensor. Connect ~ common on terminal 26. The signals from the external sensors are associated as follows: sensor signal on terminal 24 (seat-lift 1) associated with feedback 3 (seat-lift 1), and sensor signal on terminal 25 (seat-lift 2) associated with feedback 4 (seat-lift 2).

\*\* ) Note

Jumper present = NO. The selection NO/NC is done by the jumper. If changing the function a power recycle is necessary.

**Note!**

Remember to isolate wires that are not in use.

**Examples of connecting power supplies**

One power for sensor system and solenoid valves:

Two power supplies, one for sensor system and one for the solenoid valves:

### Step 1

- **Always** read the technical specifications thoroughly (see chapter 3).
- **Always** have the *ThinkTop*® electrically connected by authorized personnel.
- **Always** install the *ThinkTop*® before valve or relay is in a safe position.

### Step 2

1. Fit the air fittings on actuator if not mounted.
2. Fit the activator stem (magnet) and tighten carefully by hand.

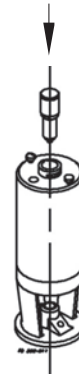

### Step 3

1. Place the *ThinkTop*® on top of the actuator.
2. Make sure X-ring is mounted.

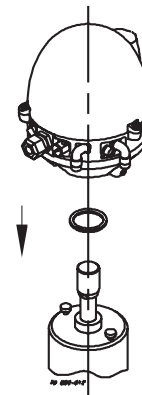

### Step 4

1. Ensure that the unit is correctly mounted by pressing down on top of the *ThinkTop*®.
2. Tighten the two Allen screws carefully.
3. Turn the actuator to have LEDs in a front view.

**Note:**

After a relevant period of time after installation (e.g. two weeks) it is recommended to check that all connections are properly tightened.

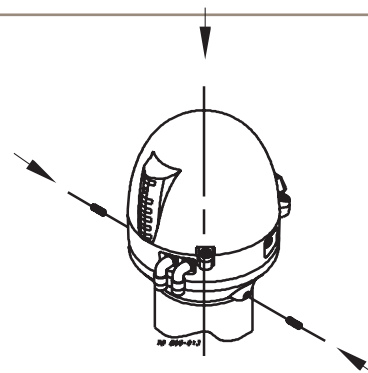

**Step 5**

Fit the  $\varnothing 6$  mm (1/4") air tubes to *ThinkTop*<sup>®</sup> (see drawing "Air connections" on page 20).

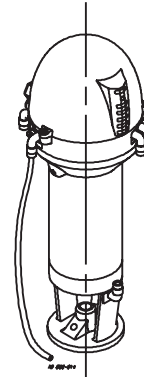

**Step 6**

Fit the air tubes to the actuator (see drawing "Air connections" on page 20).

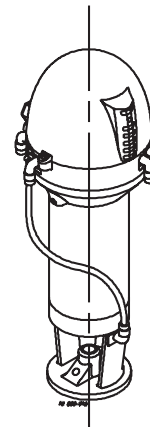

**Step 7**

Untighten the four screws and pull off cover of *ThinkTop*<sup>®</sup>.

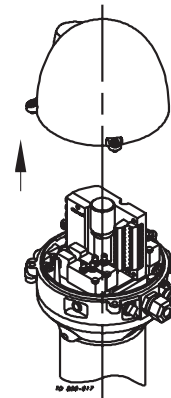

**Step 8**

1. Install cable (if not present) through the cable gland.
2. Connect the *ThinkTop*<sup>®</sup> electrically (see page 16).

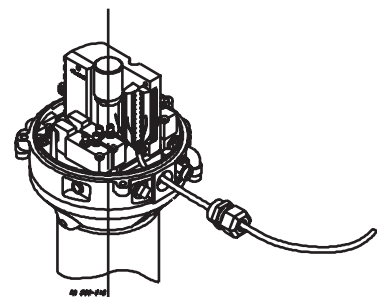

**Step 9**

Make sure the cable gland is completely tightened.

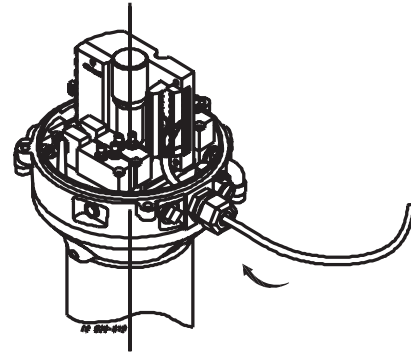

**Step 10**

Set up the *ThinkTop*® (see setup diagram page 21 and 22).

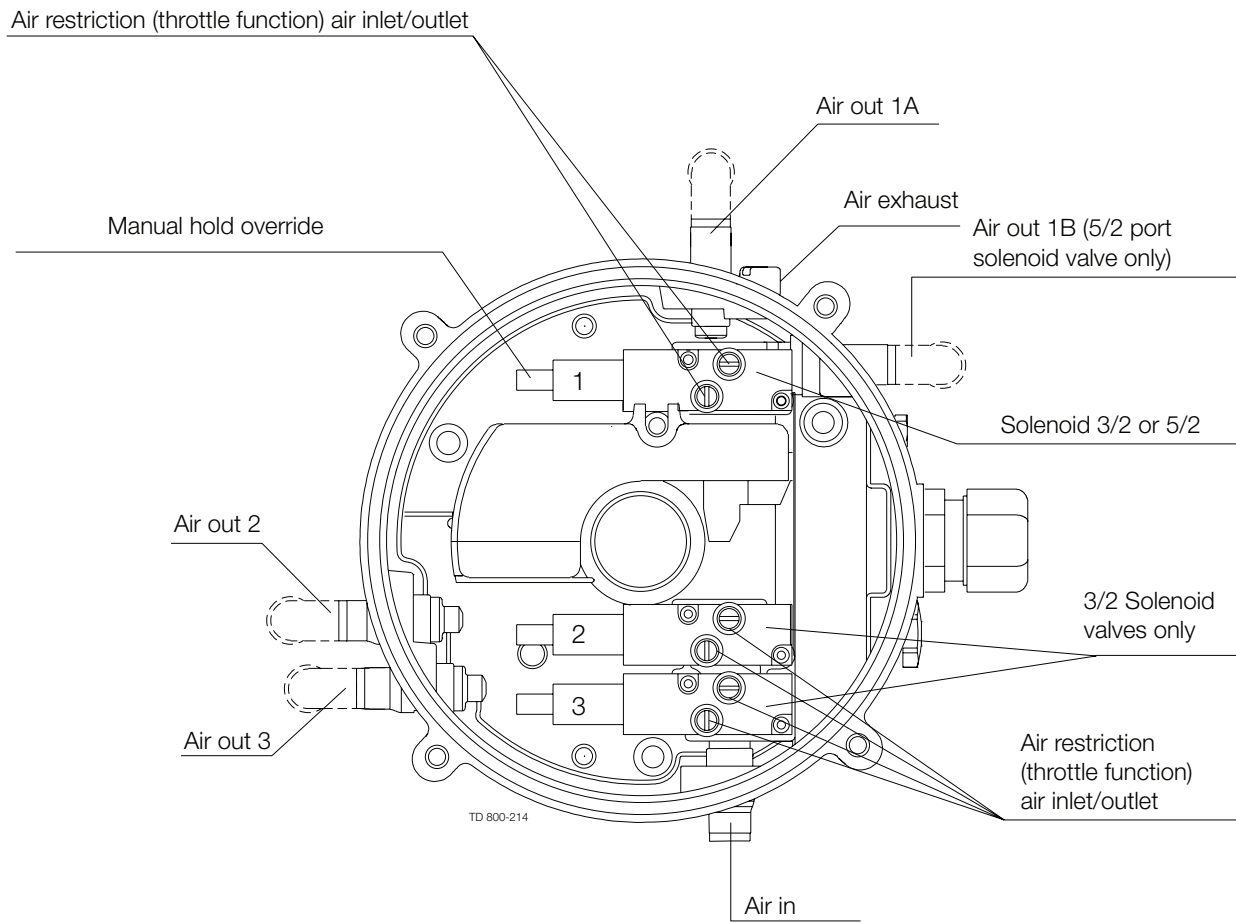

ThinkTop® setup utilizing local 'I' and 'II' Keys

- Notes:
- I - Scroll across, no change
  - \_\_\_\_\_ - Notes Requires Key Function
  - - Notes Automatic Progress as Indicated

- General:
1. Flashing IND means no value set. Steady IND means value set as shown.
  2. Default is: Step 2, Type 0 (+/- 5 mm) Step 3-8 disabled
  3. Lamp Status Shown in [ ]

ThinkTop® Visual Indications

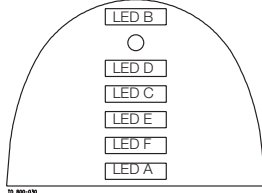

LED Indications

- \*Open valve\* (Yellow)
- \*Setup/Internal fault\* (Red)
- \*Seat-lift 1/2\* (Yellow)
- \*Solenoid valves\* (Green)
- \*Maintenance\* (Orange)
- \*Closed valve\* (Yellow)

4. [D] IND active during set-up.
  - Flashing in step 1,
  - Steady in all other steps.
 or during operations, error condition
  - Steady showing hardware fault
  - Flashing showing software fault
5. Timeout: A 60 second time-out is started as soon as any button(s) are released. If no button is pressed during the time-out time, go to normal condition (cancel & exit).

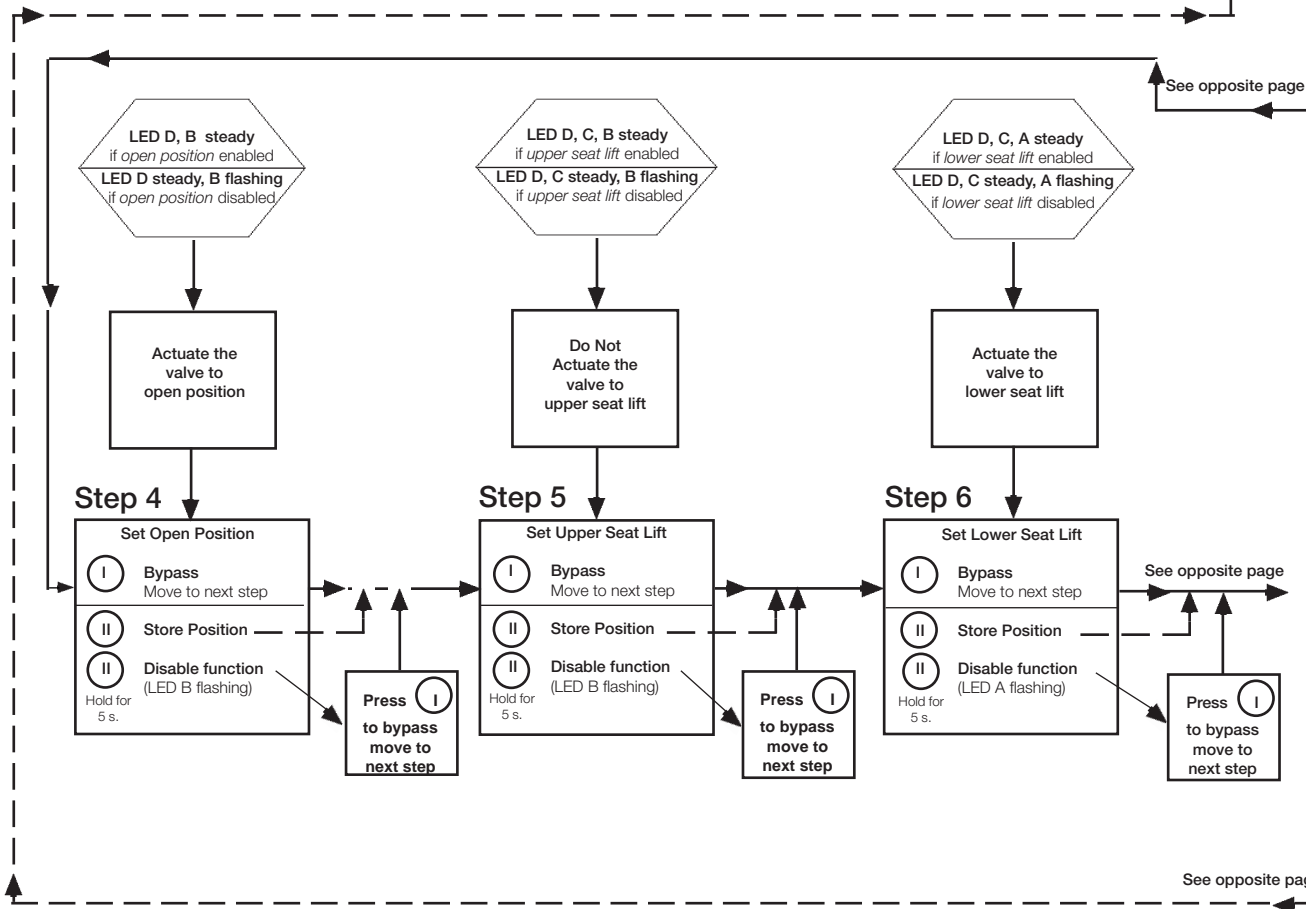
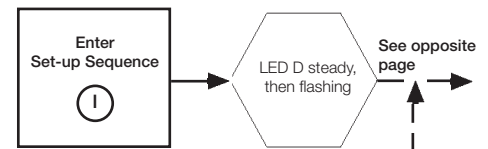



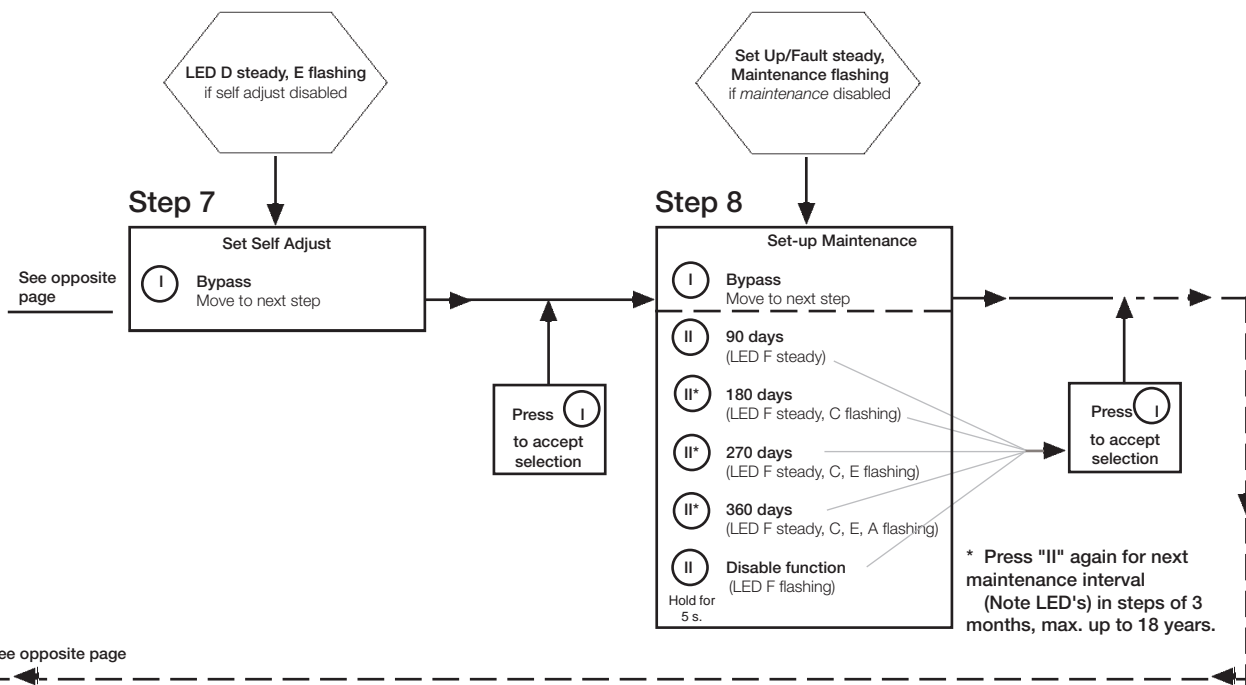
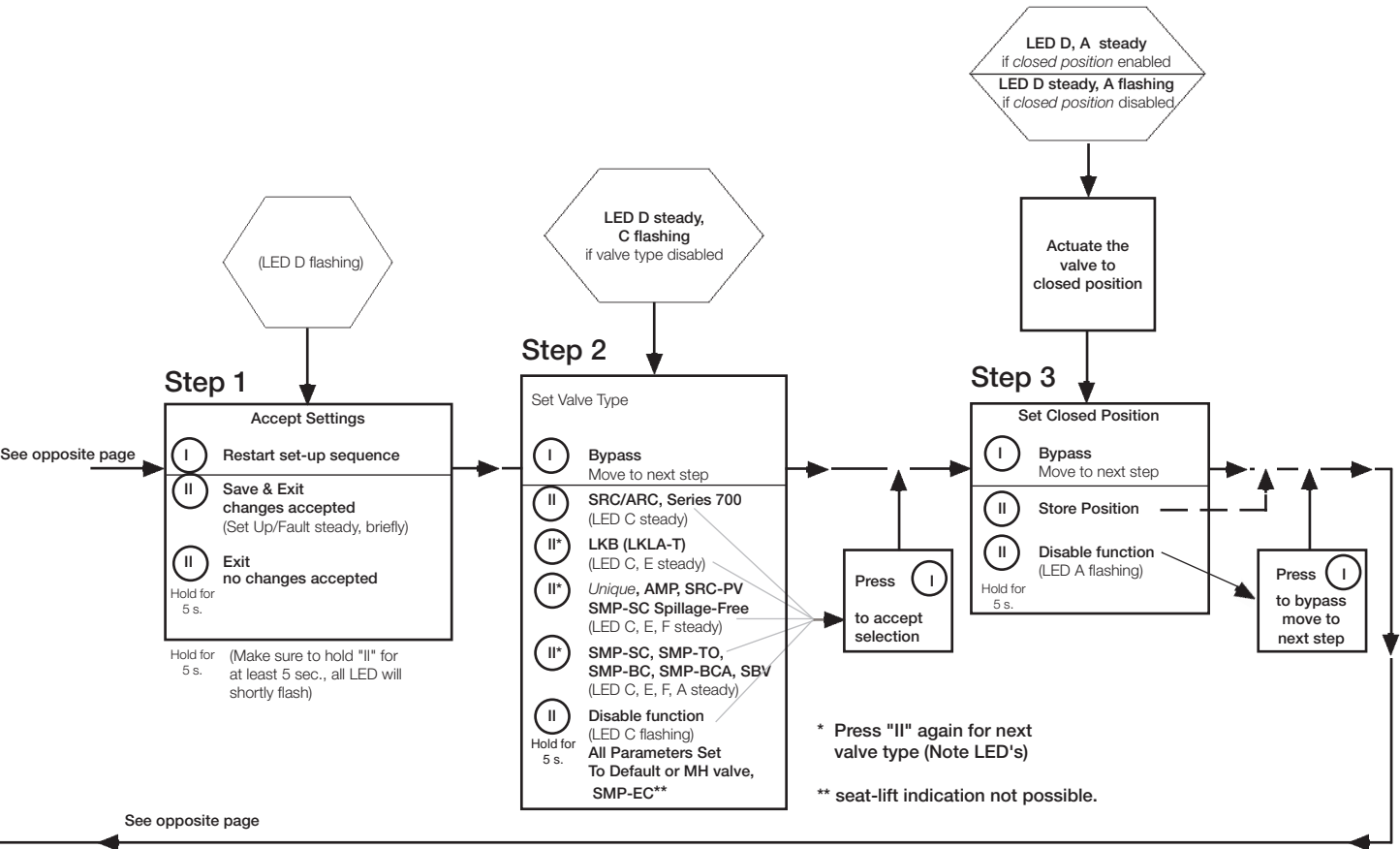

Below is stated the meaning of the LEDs' indications for fault finding in connection with the operation of the ThinkTop®.

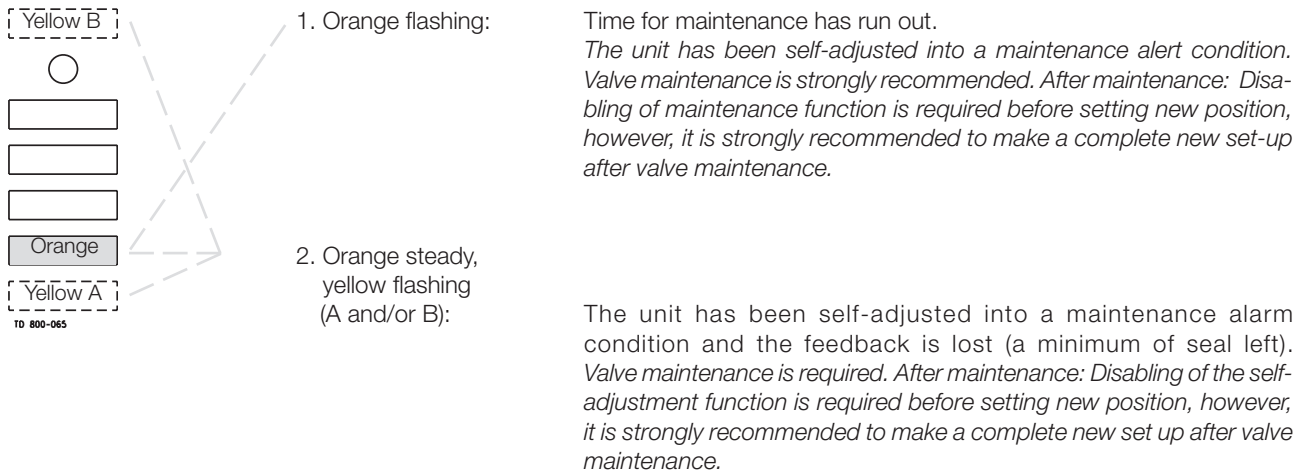
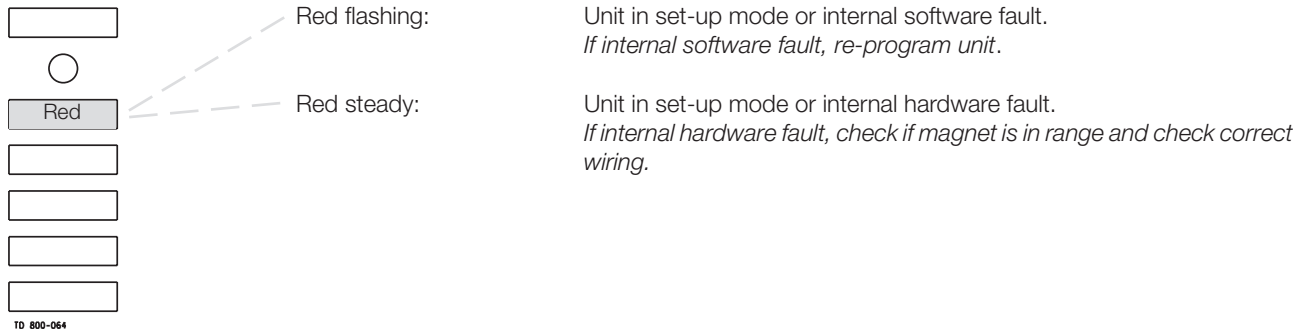

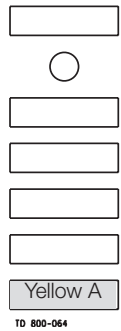

TD 800-064

Yellow steady: Position A (closed valve).

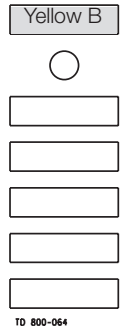

TD 800-064

Yellow steady: Position B (open valve).

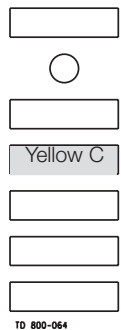

TD 800-064

Yellow steady: Position C (Seat lift 1-2 or external sensors).  
Green steady: Solenoid valves activated.

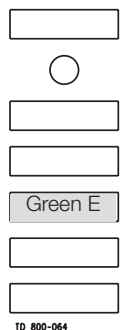

TD 800-064

Note: During set-up LED lights have different functions.

Study the instructions carefully.  
Handle scrap correctly.  
Always keep spare X-rings in stock.

**Step 1**

1. Remove the *ThinkTop*® from the actuator.
2. Pull out X-ring and replace it.

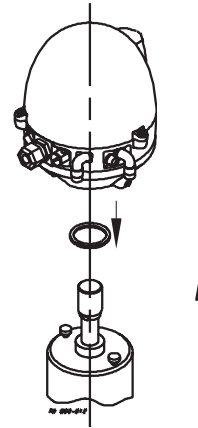

**Step 2**

1. Untighten the four screws.
2. Pull off cover of *ThinkTop*®.

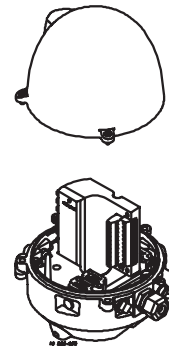

**Step 3**

1. Untighten screws.
2. Remove solenoid valves (up to three) and replace them with new ones.

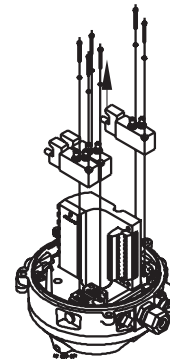

**Step 4**

1. To dismantle the adapter (the lower part of the *ThinkTop*®) from base (the middle part), unscrew the three screws.
2. Turn the lower part a little clockwise and pull.
3. Replace adapter if necessary.

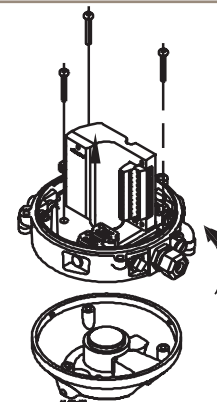

Note:  
Turn banjo  
connection!

*Study the instructions carefully.*  
*Handle scrap correctly.*  
*Always keep spare X-rings in stock.*

---

**Step 5**

To remove the sensor unit untighten screw and pull out the sensor unit.

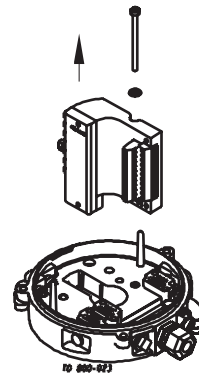

Study the instructions carefully.  
 Handle scrap correctly.  
 Always keep spare X-rings in stock.

**Step 1**

Place sensor unit in base and tighten screw (torque: 1 Nm).

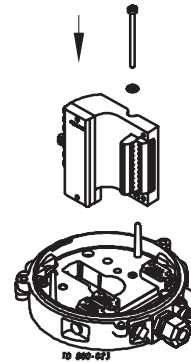

**Step 2**

Assemble base with adapter by turning adapter slightly anticlockwise and tighten the three screws (1.9 Nm).

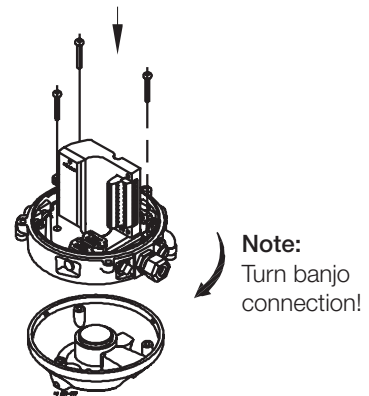

**Step 3**

1. Replace solenoid valves (up to three) with new ones.
2. Tighten screws (0.2 Nm).

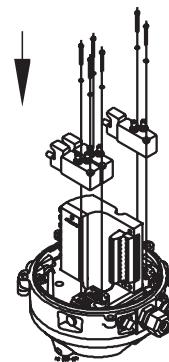

**Step 4**

Replace cover of ThinkTop® and tighten the four screws (0.6 Nm).

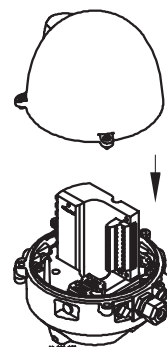

*Study the instructions carefully.*  
*Handle scrap correctly.*  
*Always keep spare X-rings in stock.*

---

**Step 5**

1. Replace X-ring.
2. Mount *ThinkTop*® on actuator.

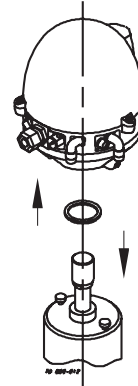



## Spare Parts

*ThinkTop*®

P/N 9612578966 } 8-30 VDC  
P/N 9612578969 }

P/N 9612990666 } 110 VAC  
P/N 9612990669 }

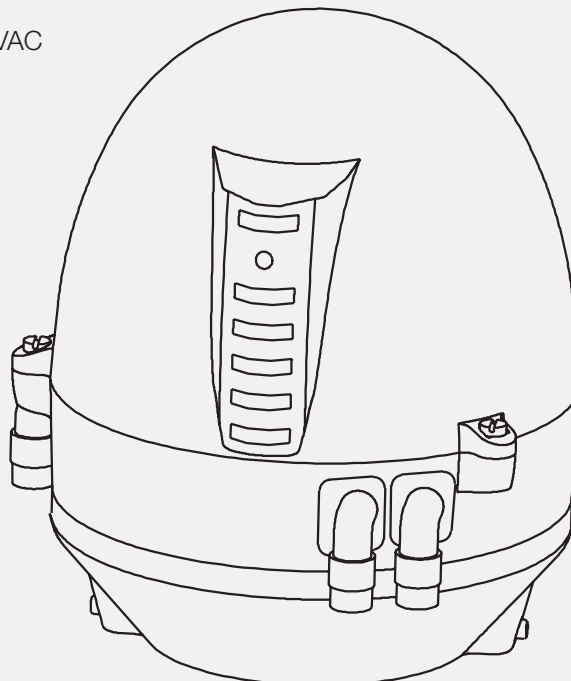

TD 800-006



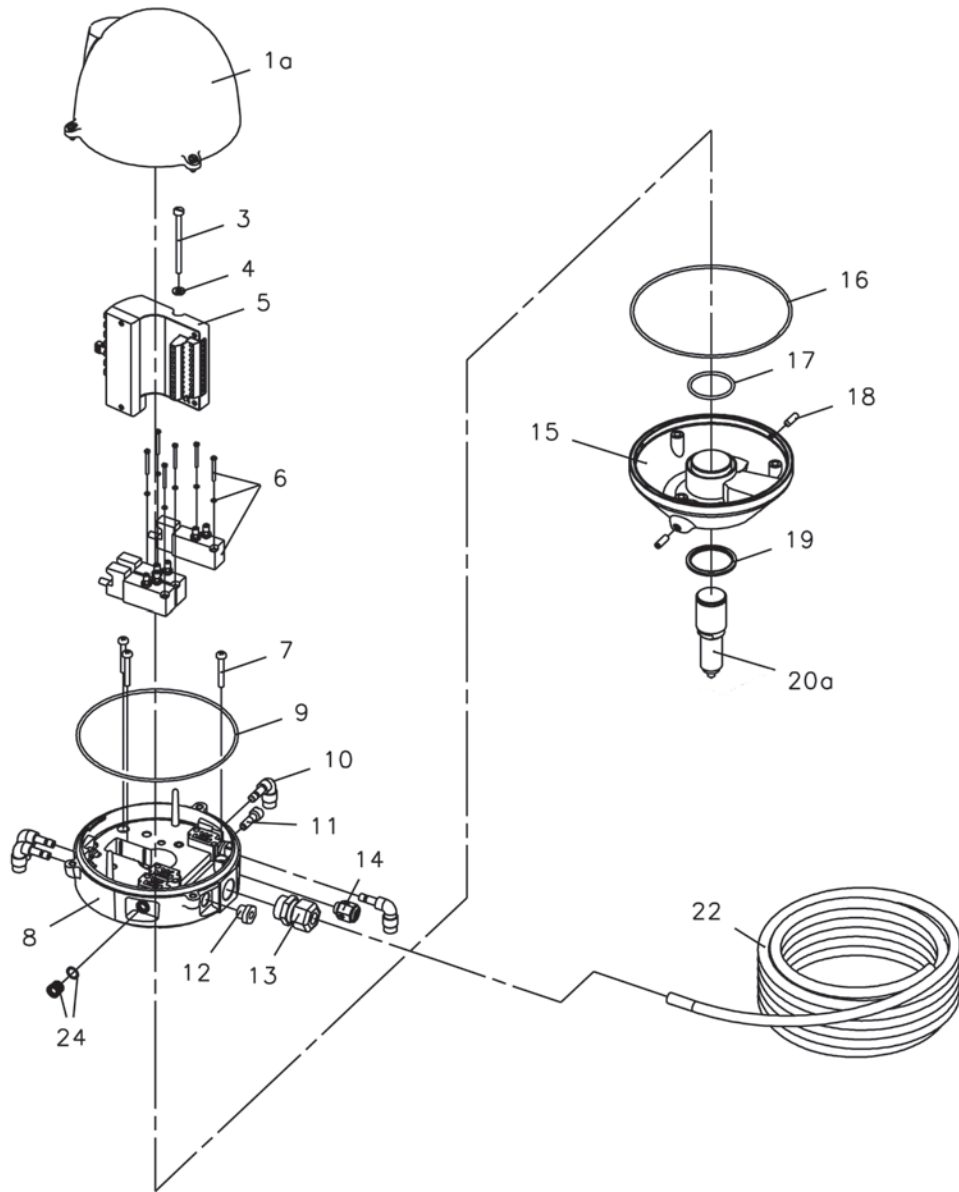

### **Recommend Cleaning – General**

In order to be compliant with the Pasteurized Milk Ordinance (PMO), the *Unique PMO Plus CP HT Series* mixproof valves shall be cleaned-in-place (CIP) with the following recommended procedures.

Each mixproof valve shall be properly operated, including seat lifting, during CIP cleaning to assure exposure to product contact surfaces.

Alfa Laval recommend that the cleaning nozzles inside the vent cavity is used during the CIP Cleaning. The nozzles are accessed though the external inlet located at the intermediate piece. The CIP though the nozzles can be controlled by a external valve.

**Recommend Cleaning – Specific**

The chart below provides reference to cleaning solution agents, temperature and exposure times necessary during circulation to achieve good cleaning results.

All data shown is required for **each** valve during cleaning.

Use clean water, free from chlorides, for mixing with chemical cleaning agents.

| CIP Event            | Exposure Time         | Temperature  | Agent                   | Concentration                     |
|----------------------|-----------------------|--------------|-------------------------|-----------------------------------|
| Warm Pre-Rinse       | 3 minutes continuous  | 100 - 110 °F | None                    | None                              |
| Hot Alkaline Wash    | 10 minutes continuous | 160 °F       | NAOH (sodium hydroxide) | .265 gal.+ 26.5 gal. water (1%)   |
| Cold Post Wash       | 3 minutes continuous  | Cold         | None                    | None                              |
| Cold Acidified Rinse | 3 minutes continuous  | Cold         | EHNO3 (nitric acid)     | .18 gal. + .265gal. water (.006%) |

**Valve Pneumatic Operation During In-Place Cleaning**  
*(Unique PMO Plus CP HT Series)*

Each valve seat shall be lifted during the length of the cleaning cycle. Seat lift durations shall not exceed 10 seconds.

These pneumatic functions include:

1. upper valve seat lift. (Cleaning of upper valve house)
2. lower valve seat push (Cleaning of lower valve house)

The following chart presents an overview of these functions together with the recommended time durations.

| CIP Event @ Length               | Valve Function  | Valve Solenoid No. | Solenoid Mode | PLC Timer Duration | Total Valve Functions Over 3 Minute Rinses and 10 Minute Washes |
|----------------------------------|-----------------|--------------------|---------------|--------------------|---|
| Warm Pre-Rinse @ 3 Minutes       | Upper Seat Lift | 3                  | Energized     | *5 sec             | 2   |
|                                  | Lower Seat Push | 2                  | Energized     | *5 sec             | 2   |
|                                  | Nozzles in Vent |                    |               | 5 sec              | 2   |
| Hot Alkaline Wash @ 10 Minutes   | Upper Seat Lift | 3                  | Energized     | *5 sec             | 5   |
|                                  | Lower Seat Push | 2                  | Energized     | *5 sec             | 5   |
|                                  | Nozzles in Vent |                    |               | 5 sec              | 2   |
| Cold Post Wash Rinse @ 3 Minutes | Upper Seat Lift | 3                  | Energized     | *5 sec             | 2   |
|                                  | Lower Seat Push | 2                  | Energized     | *5 sec             | 2   |
|                                  | Nozzles in Vent |                    |               | 5 sec              | 2   |
| Cold Acidified Rinse @ 3 Minutes | Upper Seat Lift | 3                  | Energized     | *5 sec             | 2   |
|                                  | Lower Seat Push | 2                  | Energized     | *5 sec             | 2   |
|                                  | Nozzles in Vent |                    |               | 5 sec              | 2   |

\*Approximately 2 seconds actual seat push average based upon 5 second PLC timer duration.

Note: **Unique PMO Plus**® Series valves can be thoroughly cleaned under gravity (atmospheric) or, pressure from the cleaning solution source pump, using seat lifting operations of the upper and lower plug seats.

**Guide Bearing Cleaning**

When the valves are removed for replacement of wetted parts and / or sealing elastomers, it is important to remove, and hand clean, the three PTFE guide rings (positions 45, 54, 80) and their seating grooves before placing the valves back into service.

See section, Maintenance, Re-Assembly Valve (points 1, 2, 5, 6, 24 and 25)

***Unique PMO Plus CP HT Valve Series* - Upper Seat Lift and Lower Seat Push**

***Unique PMO Plus CP HT Valve Series* - Upper Seat Lift  
 Flow of Cleaning Solution Through Valve Vent (example)**

The table below approximates the flow of cleaning solution through the valve vent tube during seat lift functions at 30 PSI CIP pressure.

(viscosity and density comparable to water)

| <b>Valve Size</b> | <b>Flow Per Second Through Vent Tube</b> | <b>Flow Every 2 Seconds Through Vent Tube</b> |
|-------------------|--|---|
| 2½" and 3"        | 0.24 gal                                 | 0.47 gal                                      |
| 4"                | 0.48 gal                                 | 0.97 gal                                      |
| 6"                | 1.10 gal                                 | 2.21 gal                                      |

Note: Refer to page 9 "CIP Solution Flows for seat lift" to determine flows for CIP pressures other than 30 PSI shown above.

***Unique PMO Plus CP HT Valve Series* - Lower Seat Push  
 Flow of Cleaning Solution Through Valve Vent Tube/O.D. Balancer (example)**

The table below approximates the flow of cleaning solution through the valve vent tube and O.D. cleaning element during lower seat push functions at 30 PSI CIP pressure.

(viscosity and density comparable to water)

| <b>Valve Size</b> | <b>Flow Per Second Through Vent Tube</b> | <b>Flow Every 2 Seconds Through Vent Tube</b> |
|-------------------|--|---|
| 2½" and 3"        | 2.74 gal                                 | 5.48 gal                                      |
| 4"                | 5.32 gal                                 | 10.64 gal                                     |
| 6"                | 12.52 gal                                | 25.05 gal                                     |

Note: Refer to page 9 "CIP Solution Flows for seat lift" to determine flows for CIP pressures other than 30 PSI shown above.

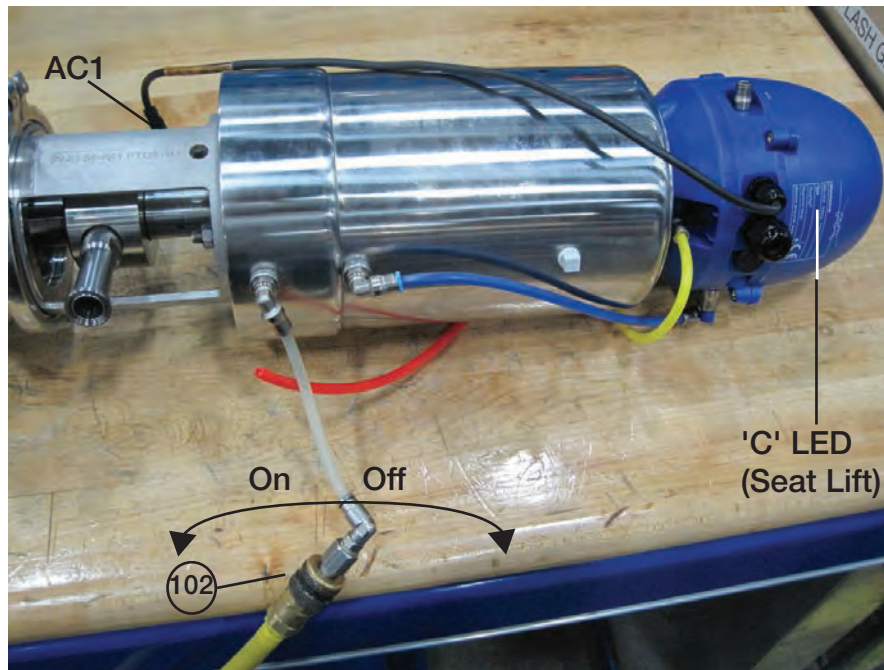
**Test - 1**  
**Upper Valve Seat**  
**Position Detection**

1. Valve at rest (closed) position
  - "C" LED (Seat Lift) on *ThinkTop* is illuminated.
2. Attach a manual air line to actuator air fitting AC1 using a 3-way air pilot switch (pos. 102).
3. Turn the air pilot switch to ON. (Open)
  - "C" LED (Seat Lift) on *ThinkTop* not illuminated.
4. Turn the air pilot switch to Off (Closed).
  - "C" LED (Seat Lift) on *ThinkTop* is illuminated.
5. Test complete. Remove manual air line.

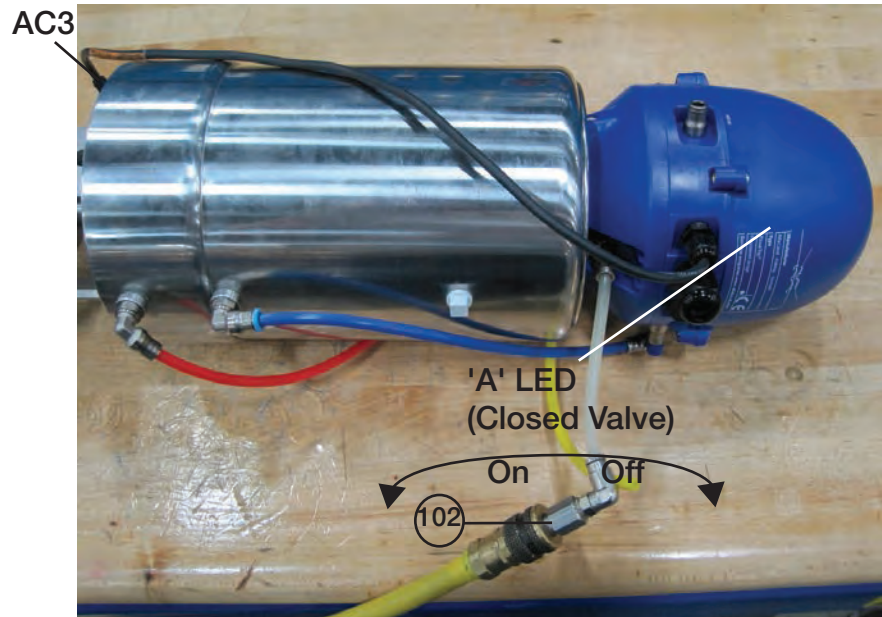
**Test - 2**  
**Lower Valve Seat**  
**Position Detection**

1. Valve at rest (closed) position
  - "A" LED (Closed Valve) on *ThinkTop* is illuminated.
2. Attach a manual air line to actuator air fitting AC3 using a 3-way air pilot switch (pos. 102).
3. Turn the air pilot switch to ON (Open)
  - "A" LED (Closed Valve) on *ThinkTop* not illuminated.
4. Turn the air pilot switch to Off (Closed).
  - "A" LED (Closed Valve) on *ThinkTop* is illuminated.
5. Test complete. Remove manual air line.



## Adjustments

Upper Valve Seat External Sensor (24VDC or 110VAC)  
(Position Data Existing on *ThinkTop*)

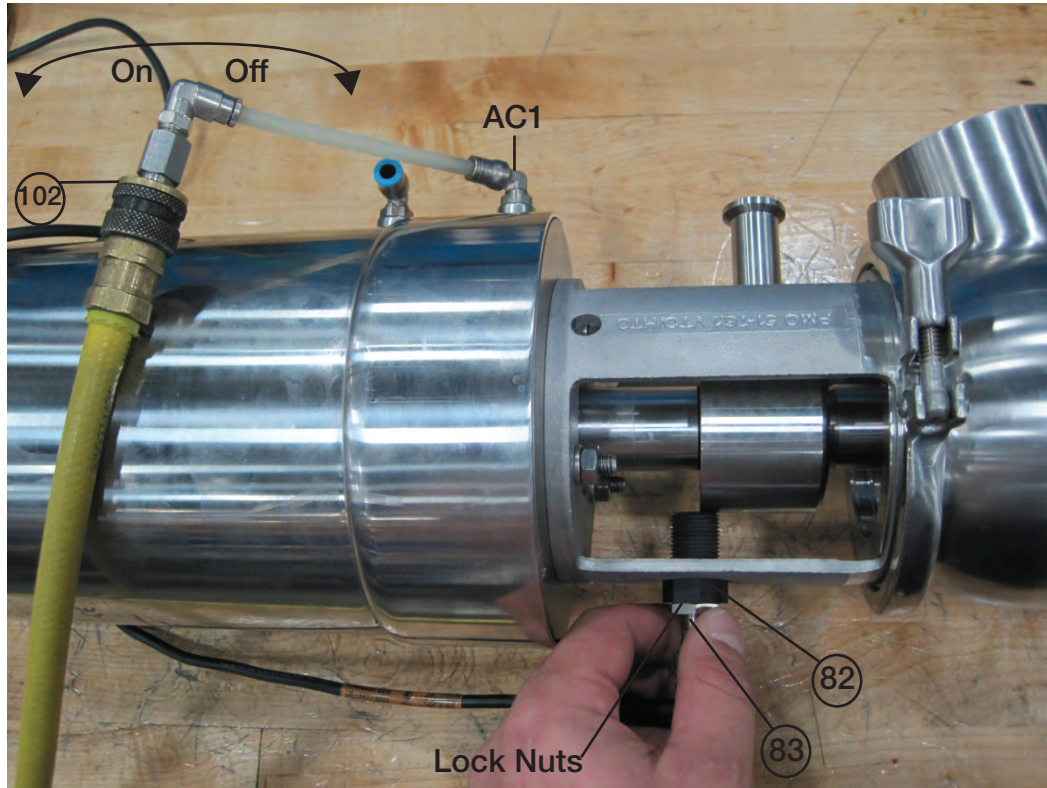

The following instructions should be made while the valve is hot from CIP cleaning. (worst case)

1. Valve is in a rest position.
2. Loosen sensor lock nut(s).
3. Turn the sensor (pos 83) clockwise to bottom of nylon plug (pos 82), (or, in some cases, until the sensor LED turns off.)
4. Turn the sensor (pos 83) counter clockwise until the sensor LED turns on, (or approximately one full turn from bottom of plug.)
5. Lightly tighten sensor lock nut(s).
6. Attach a manual air line to actuator fitting AC1 using a 3-way air pilot switch (pos 102).
7. Turn the air pilot switch to ON (open). Upper seat lift activated. Sensor LED turns off.
8. Turn the air pilot switch to OFF (closed). Upper seat lift de-activated. Sensor LED turns on.
9. Turn the air pilot switch ON and OFF several times to verify sensor LED actions as listed in steps 7 and 8 above.
10. Moderately tighten sensor lock nut(s).
11. Repeat step 9 when the valve is cold and re-adjust with valve hot if necessary.

See pages 66 to 74 for part numbers.



### Adjustments

Upper Valve Seat *ThinkTop*  
(Set Position New on *ThinkTop*)

The following instructions can be completed while the valve is at room (ambient) temperature.

1. Enter new 'UPPER SEAT LIFT' position data to the *ThinkTop* memory in step 5 of the programming sequence using the 'I' and 'II' keys.

**Note: Data entry is done with the valve deactivated (Closed).**

2. Adjust lateral sensor per instructions for 'UPPER VALVE SEAT EXTERNAL SENSOR' in this section.

Refer to "Electrical Connections/Instructions" in this manual for *ThinkTop* programming.

### Adjustments

Lower Valve Seat *ThinkTop*

The following instructions can be completed while the valve is at room (ambient) temperature.

1. Delete the current 'CLOSED VALVE' position data from the *ThinkTop* memory using the 'I' and 'II' keys.
2. Enter new 'CLOSED VALVE' position data to the *ThinkTop* memory using the 'I' and 'II' keys.
3. Repeat 'Test - 2, Lower Valve Seat Position Detection' procedures to confirm adjustment.

Refer to "Electrical Connections/Instructions" in this manual for *ThinkTop* programming.

**Test - 3**  
**Regulatory Inspection,**  
**Confirm Control System Seat Lifting**  
**Interlock During an Operating, active CIP Circuit**

Description of components to be used for this test:

1. *ThinkTop*® (blue control module located on top of the air actuator)
2. Compressed air solenoids (when furnished inside *ThinkTop*®\*\*) see page 20 for top view of solenoid layout inside *ThinkTop*®.
  - a. Solenoid-1, valve full open. (Note: not used for this test procedure)
  - b. Solenoid-2, lower seat push activation.
  - c. Solenoid-3, upper seat lift activation.

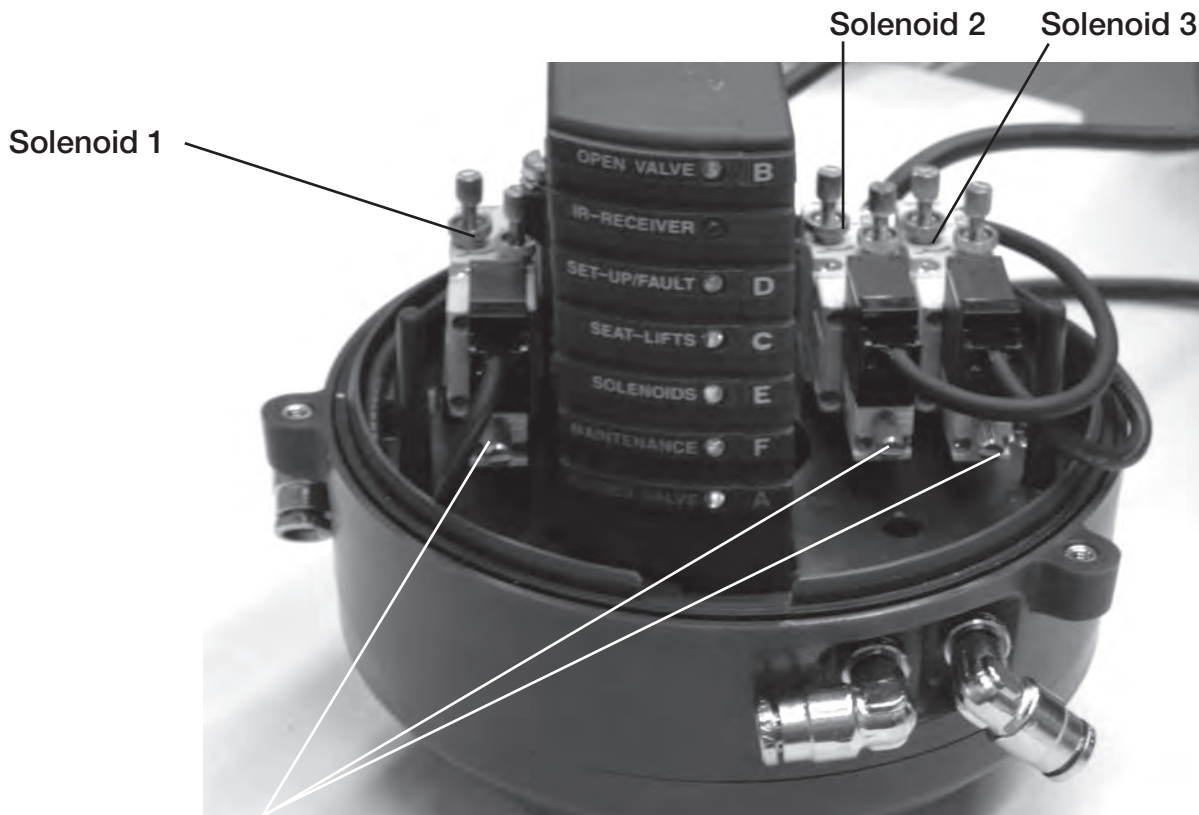

**Manual Air Pilot Buttons**

Test procedure listed as follows:

1. Select a Unique PMO Plus CP HT mixproof valve for interlock testing.
2. Decide if the cleaning solution will flow through the mixproof valve upper or lower body as part of the CIP cleaning circuit for the test.
3. Start the appropriate CIP circuit. (WARNING: be sure that there is no risk of mixing product with cleaning solution when conducting this test!!)
4. The CIP supply pump, or source of CIP solution pressure, should now be operating.
5. Remove the cover lid from the Think Top.

Move to step 6 or 7 below:

6. If cleaning solution is flowing through the valve upper body, push and hold the silver manual air pilot button on solenoid number 2 (lower seat push). If control system interlock is correct, the CIP supply pump, or source of CIP solution pressure, will be de-activated. Release manual air pilot button to end this test.
7. If cleaning solution is in the tank, push and hold the silver manual air pilot button on solenoid number 3 (upper seat lift). If the control system interlock is correct, the CIP supply pump, or source of CIP solution pressure, will be de-activated. Release manual air pilot button to end this test.
8. If the control system does NOT de-activate the cleaning solution pressure source as described in either 6 or 7 above, the control system should be shut down for evaluation, and correction, to the interlock functions written in the PLC logic.

\*\* If solenoids are located in a remote enclosure (not inside Think Top), the above test procedures are to be conducted in exactly the same method. Selection of the proper solenoids for testing are to be determined using the assistance of plant operating personnel.

*General Maintenance:*

*Replace all product wetted seals every 12 months.*

---

**Tools Required for Valve Service**

- 2 x 16mm Wrench
- Strap Wrench - 19mm and 13mm
- 8mm Wrench
- 17mm Wrench
- 2.5mm Allen Wrench
- Small Knife
- Straight Pick
- Small Standard Screw Driver
- Air Pilot Switch (Pos. 102)

**Tools Required for Actuator Service**

- 13mm Wrench
- Long Stem Phillips Screw Driver (#2 Point)
- Plastic Hammer
- Small Blunt Face Punch
- Small Standard Screw Driver

### Dis-Assemble Valve (Excluding Actuator)

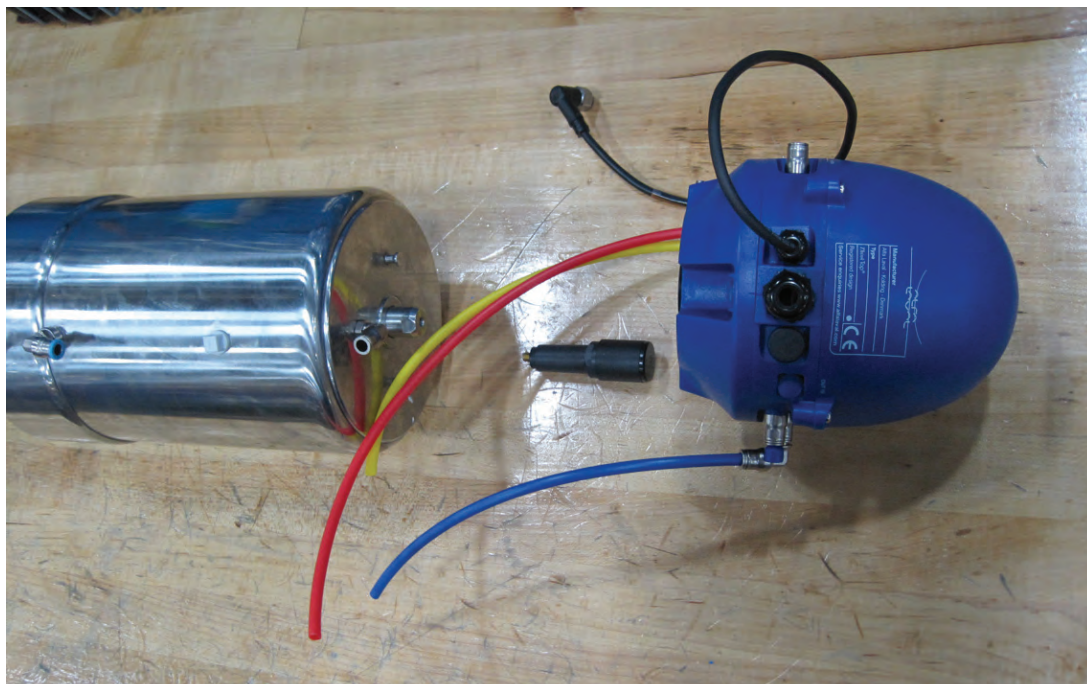

1. Remove *ThinkTop*.



2. Activate main stroke.



3. Remove clamp.
4. Remove valve.
5. Release air.



6. Remove flushing pipe using 19mm wrench.

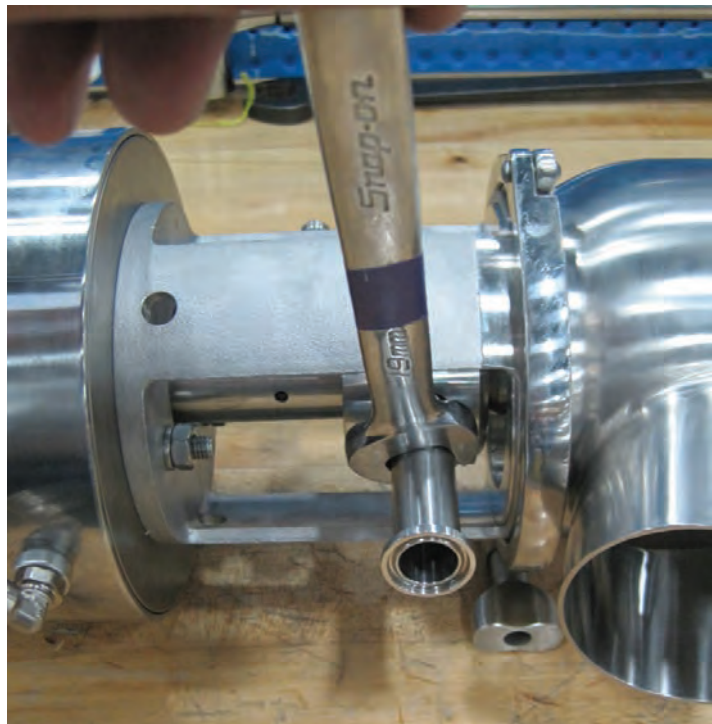

7. Remove clamp rings.

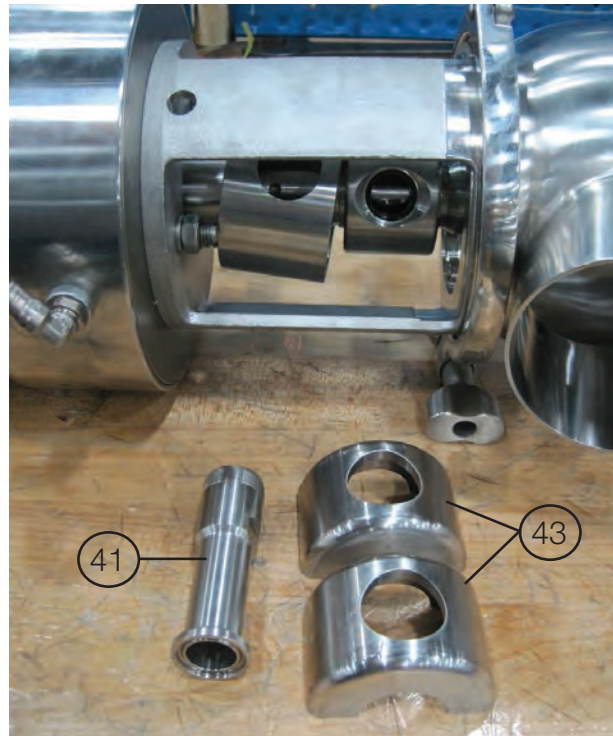

8. Activate upper seat lift.

9. Loosen lower plug by using 2 16mm wrenches.



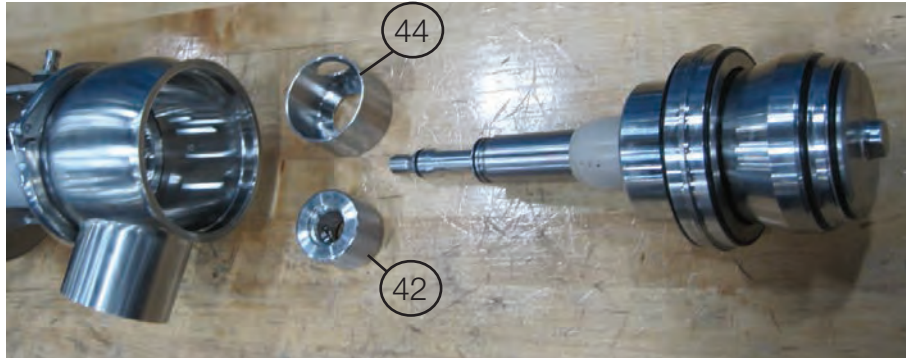

- 10. Turn out lower plug by hand and remove plug assembly.
- 11. Remove spindle liner and lock ring.



- 12. Remove upper stem by using a 13mm and a 16mm wrench.

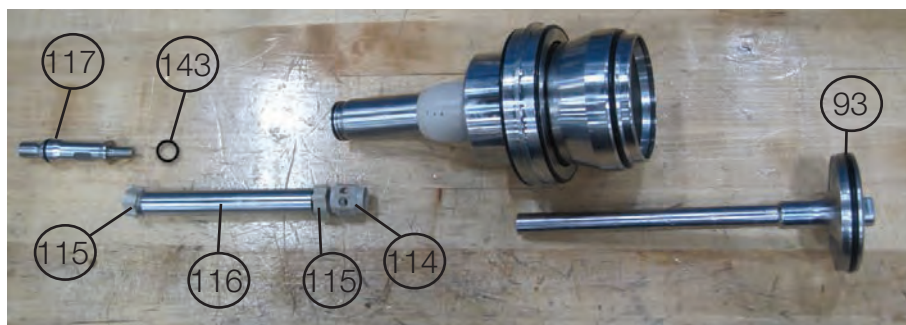

See pages 66 to 74 for part numbers.





13. Remove lock ring and rotating nozzle by pulling upwards.

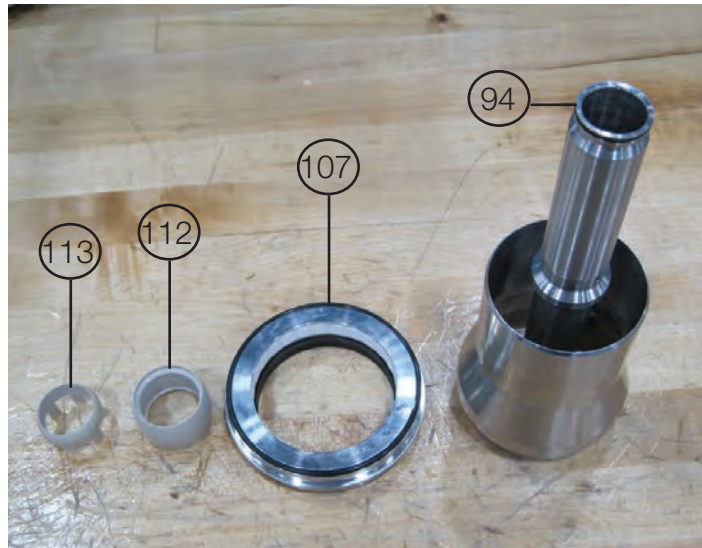

14. Remove valve body sealing element.



15. Sanitize guide ring.

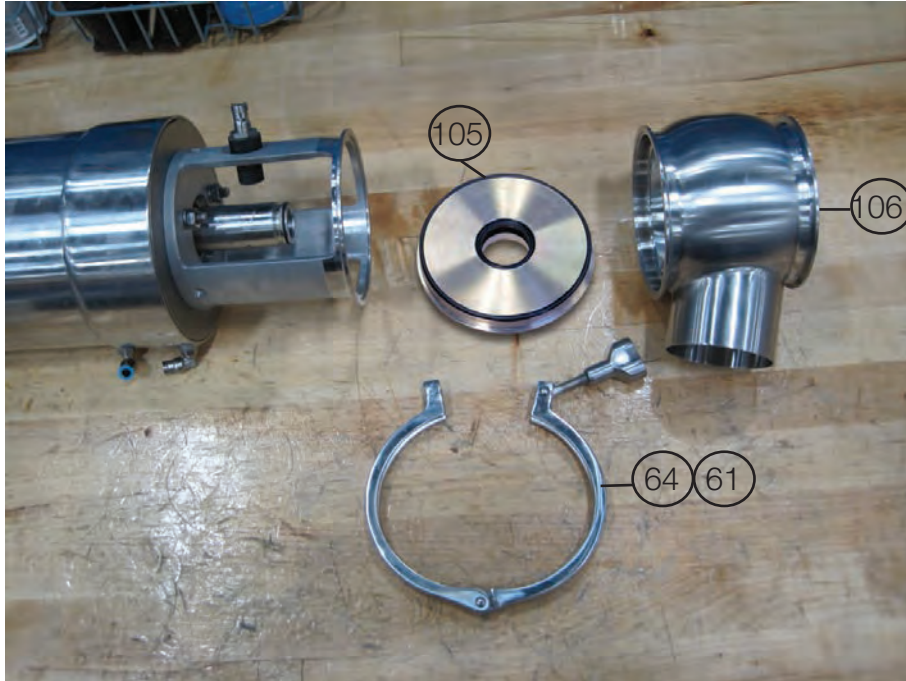

16. Remove clamp, vent body and sealing element.

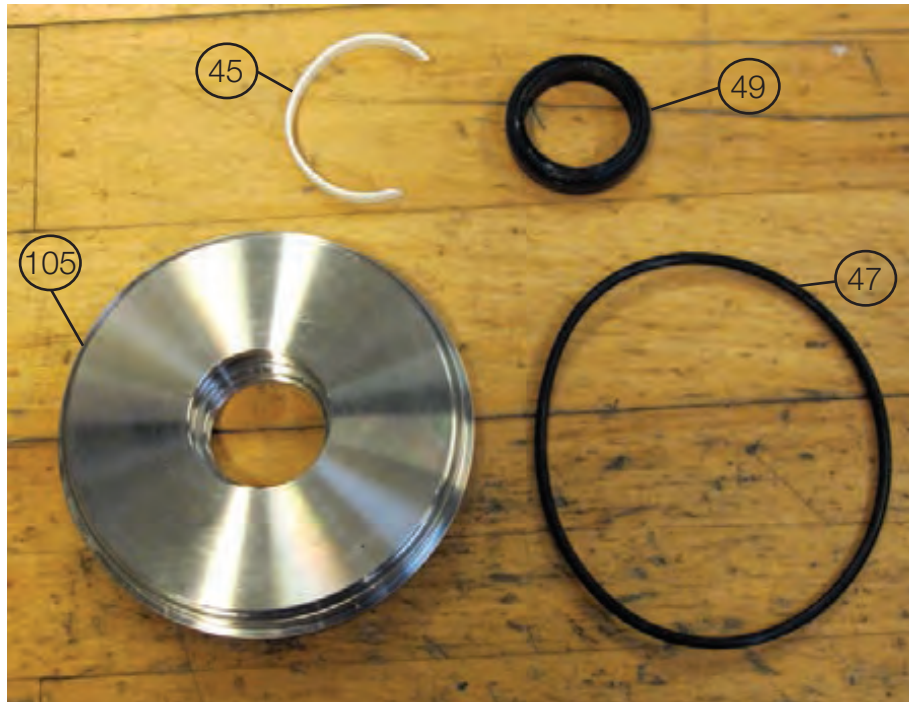

17. Sanitize guide ring.

Study the instructions carefully. Handle scrap correctly.

### 3. Replacement of seal ring, lower plug

**Step 1** Cut and remove old seal ring (74) using a knife, screwdriver or similar. Be careful not to scratch the plug.

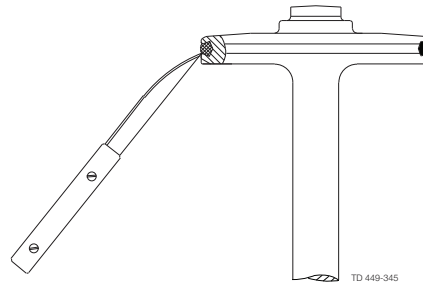

**Step 2** Pre-mount seal ring as shown on drawing.

Rotate along circumference to fix gasket as shown in the picture

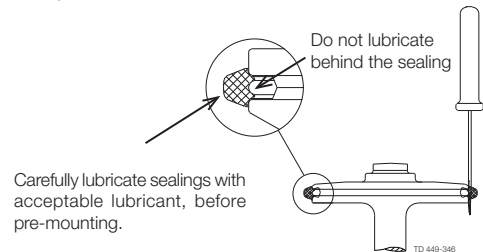

**Step 3** Place lower tool part.

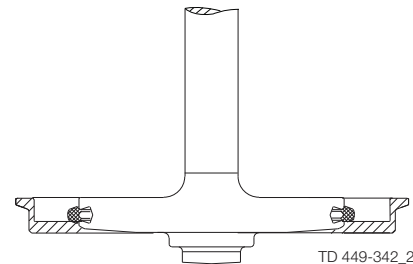

**Step 4**  
1. Place upper tool part including piston.  
2. Clamp the two tool parts together.

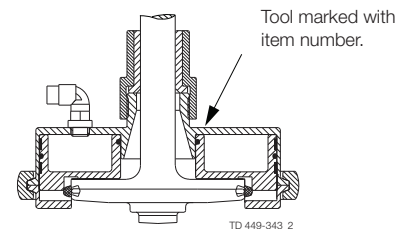

**Step 5**  
1. Supply compressed air.  
2. Release compressed air.  
3. Remove tool parts

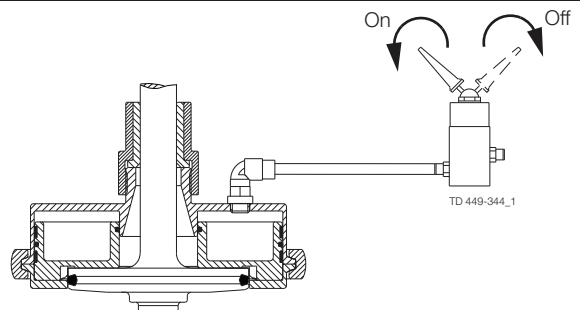

**Step 6** Inspect the seal to ensure it does not twist in the groove, and press in the 4 outsticking points with a screwdriver.

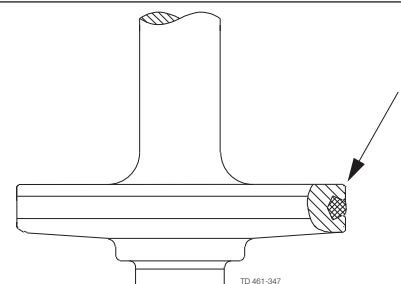

*Study the instructions carefully. Handle scrap correctly.*

#### 4. Replacement of seal ring, upper plug

**Step 1** Remove old seal ring (56) using a knife, screwdriver or similar. Be careful not to scratch the plug.

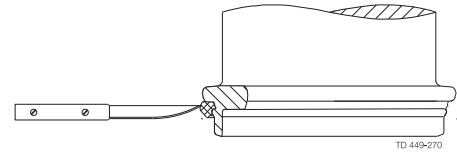

**Step 2** Pre-mount seal ring as shown on drawing.

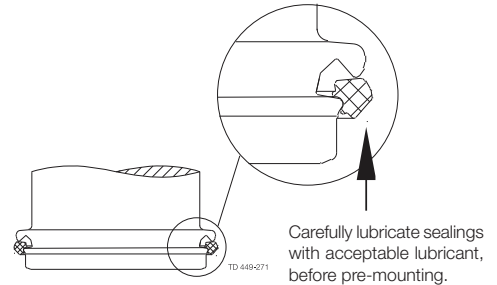
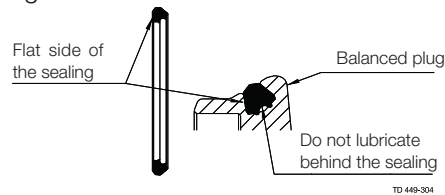

**Step 3** Place tool part 1.

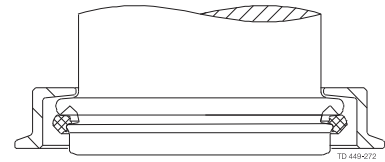

**Step 4**

1. Place tool part 2 including piston.
2. Clamp the two tool parts together.

Tooling marked with item number

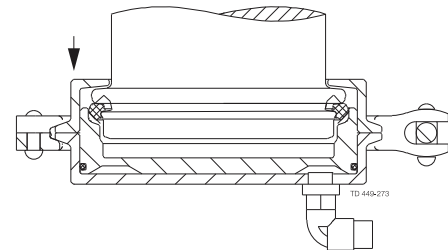

**Step 5**

1. Supply compressed air.
2. Release compressed air.
3. Rotate the tool 45° with regards to the plug.
4. Supply compressed air.
5. Release compressed air and remove tool.

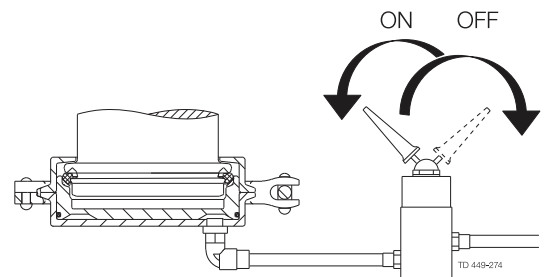

**Step 6**

1. Inspect the seal.
2. Release air at 3 different positions of the circumference.

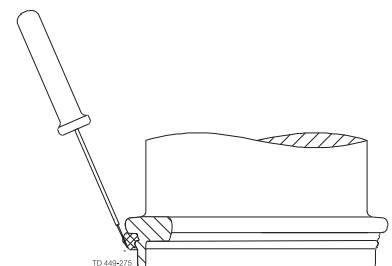

See pages 66 to 74 for part numbers.



**Re-Assemble Valve**  
(Excluding Actuator)

**Assembly valve body sealing element:**



1. Lubricate o-rings & lip seal.
2. Mount all components in sealing element.



Mounting rotating nozzle and O-ring on upper plug:



3. Lubricate o-ring.



4. Nozzle and lock ring slides over spindle.



5. Mount o-ring on upper plug.

**Mounting valve body sealing element on upper plug:**

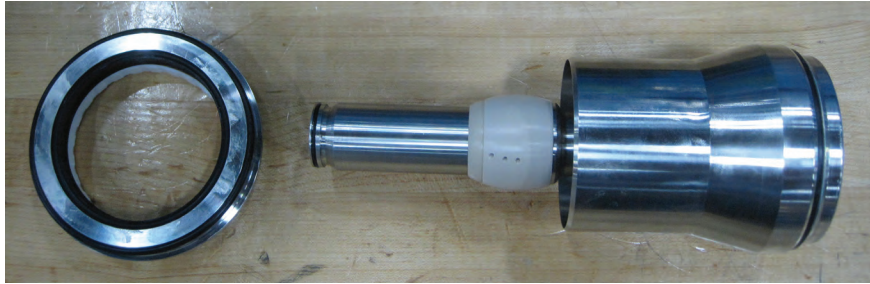

6. Ensure sealing element is orientated so the white guide ring is upwards.



**Mounting two-way nozzle, spacer and guide rings:**

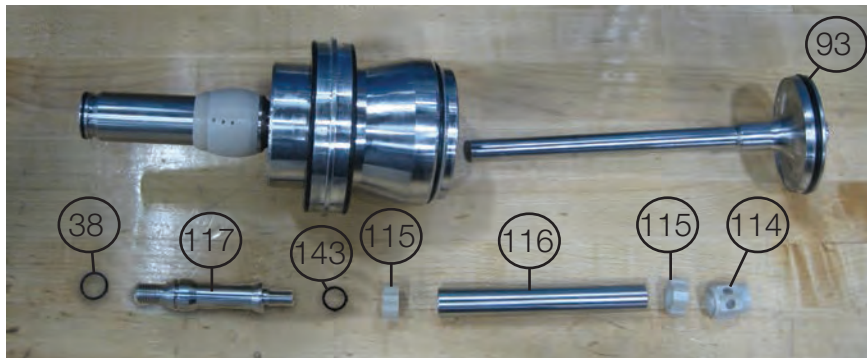

7. Lubricate o-ring.



8. Insert nozzle, ensure that it is inserted as shown on picture.



9. Insert first guide ring.





10. Insert spacer.



11. Insert last guide ring.



12. Insert tank plug from the bottom of upper plug.





13A and 13B.  
Mount stem for  
lower plug.



14. Tighten. Use a 13mm and 16mm wrench.  
Torque 20Nm.

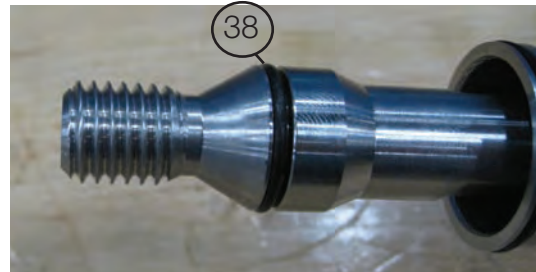

15. Mount o-ring.

**Mounting yoke on actuator:**

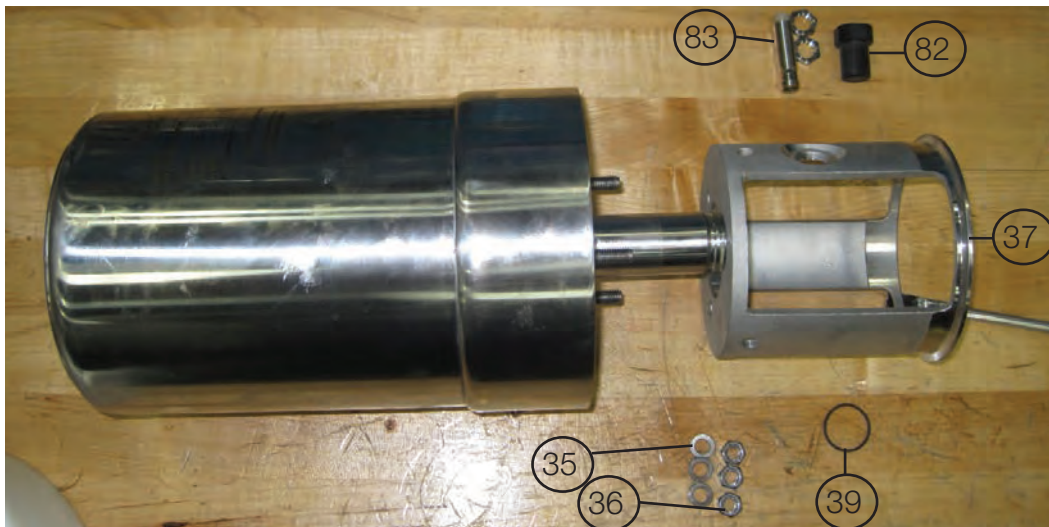

16. Lubricate o-ring.

See pages 66 to 74 for part numbers.



- 17. Mount yoke and the 3 nuts and washers.
- 18. Use a 13mm wrench. Tighten nuts to 12Nm.
- 19. Mount o-ring on actuator spindle.
- 20. Mount plastic bolt and sensor.

**Assembly vent body sealing element:**

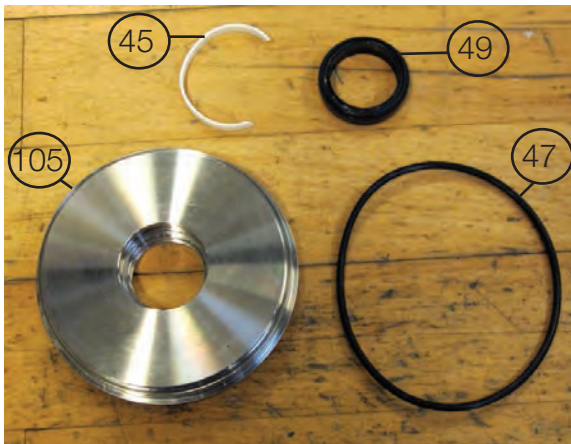

- 21. Lubricate o-rings and lip seal.
- 22. Mount all components in sealing elements.



**Assembly valve:**

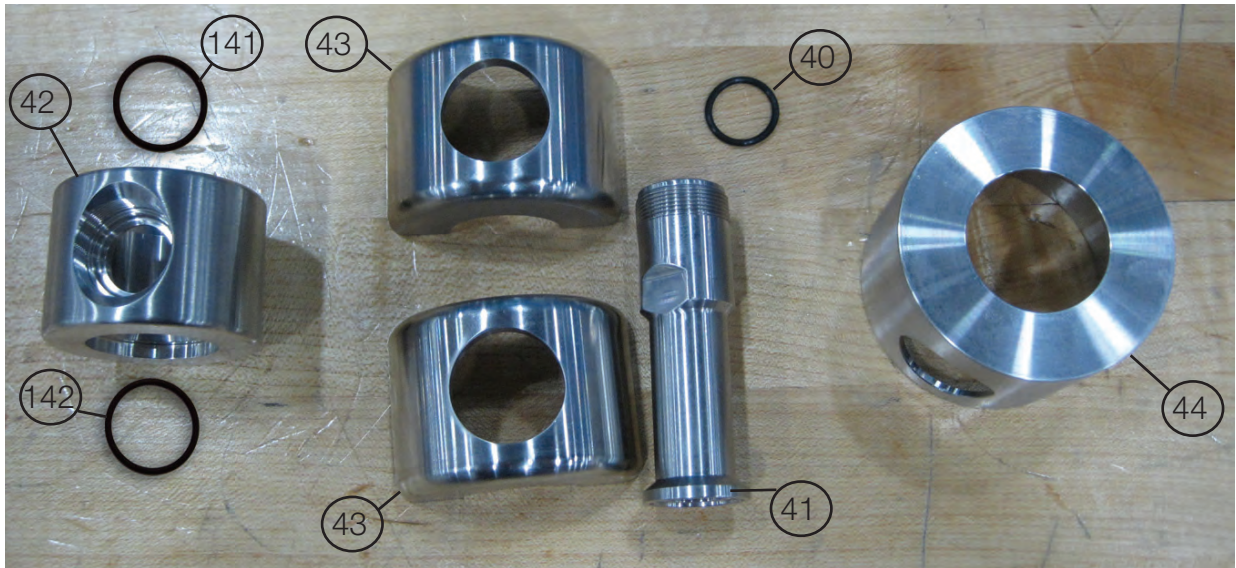

23. Lubricate o-ring.



24. Place sealing element with o-ring and lip seal upwards.



25. Mount the o-ring.

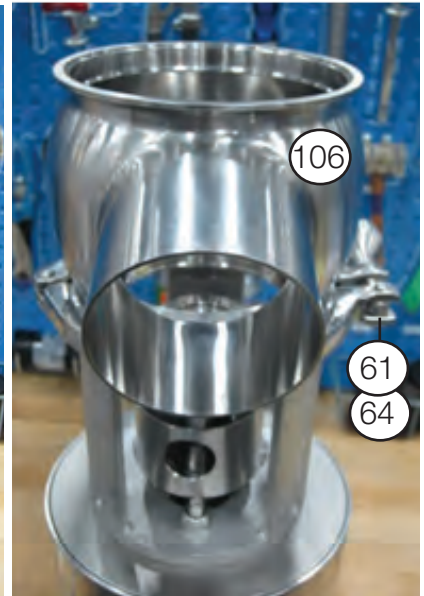

26. Mount vent body.

27. Mount clamp.

See pages 66 to 74 for part numbers.

Effective 05/04/2012



- 28. Activate compressed air on lower seat push (yellow air fitting placed on top of actuator).
- 29. Insert valve plug assembly through vent sealing element.
- 30. Tighten lower plug by hand.

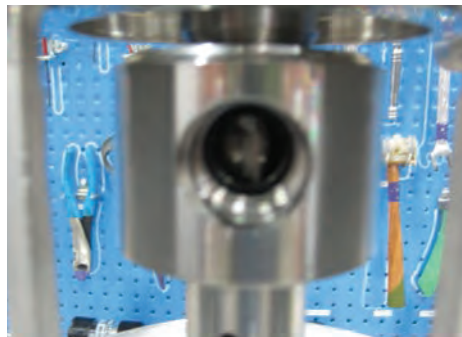

- 31. Mount clamp rings, ensure that hole in clamp and spindle liner are aligned.
- 32. Push up the lock ring.
- 33. Align hole in lock ring with the other holes.
- 34. Insert O-Ring



- 35. Mount flushing pipe. tighten with 19mm wrench.
- 36. Deactivate lower seat push.
- 37. Activate compressed air on main stroke (blue air fitting placed mid on actuator).



- 38. Mount valve body and clamp.
- 39. Deactivate main stroke.

### **Dismantling of actuator**

1. Remove nuts (36) and washers (35).
2. Pull out intermediate piece (37) from the actuator.
3. Remove cover disk (25).
4. Remove retaining ring (24).
5. Remove piston rod (29), bottom (21) and lower piston (30).
6. Separate the three parts.
7. Remove O-rings (20, 22 and 23) from bottom, O-rings (33 and 31) and guide ring (32) from lower piston as well as O-ring (28) from piston rod.
8. Remove spring assembly (14).
9. Remove inner stem (27), main piston (17) and distance spacer (11) if present. Remove guide ring (18) and O-ring (19).
10. Remove spring assembly (10).
11. Unscrew screws (2).
12. Remove stop (4).
13. Remove upper piston (8). Remove O-rings (7 and 9).
14. Remove O-ring (5) and guide ring (6).



### Actuator Exploded View

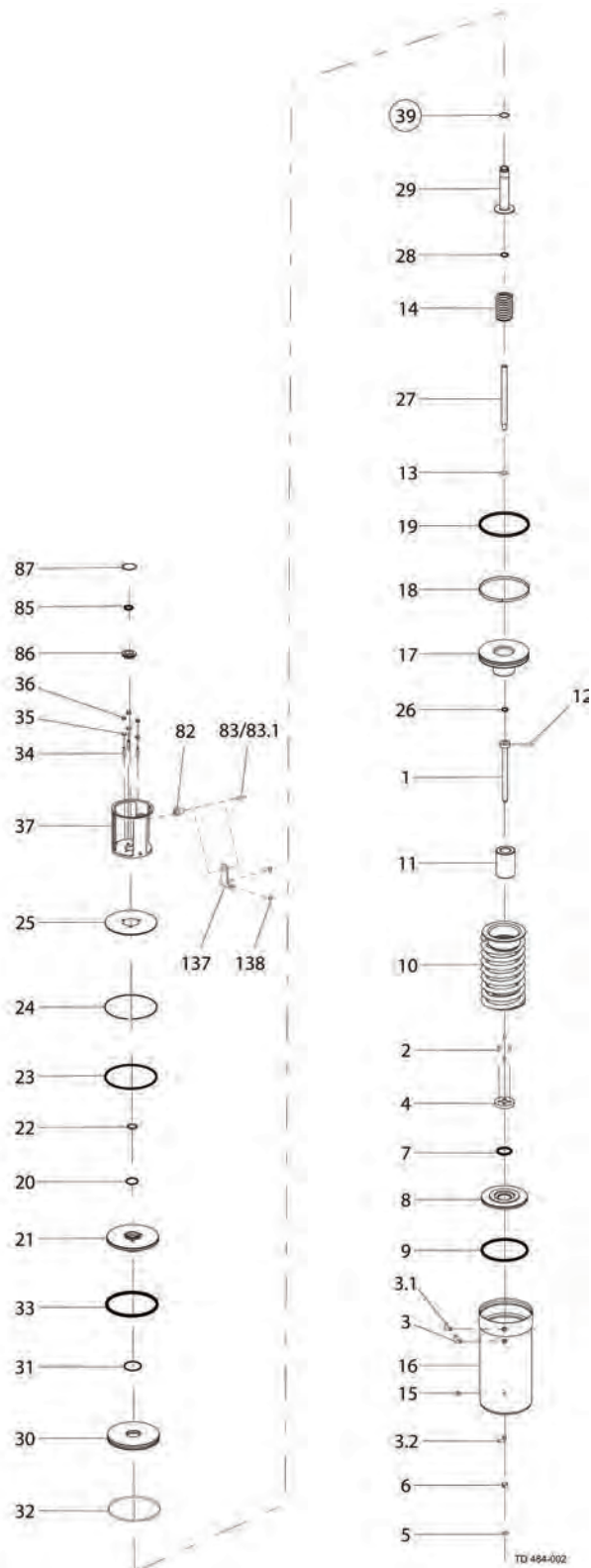

### Reassembly of actuator

1. Fit guide ring (6) and O-ring (5).
2. Fit O-rings (7 and 9). Place upper piston (8).
3. Fit stop (4).
4. Tighten screws (2).
5. Place spring assembly (10).
6. Fit O-ring (19) and guide ring (18). Mount distance spacer (11), main piston (17) and inner stem (27).
7. Fit spring assembly (14).
8. Fit O-ring (28) in piston rod, fit O-rings (33 and 31) and guide ring (32) in lower piston and fit O-rings (20, 22 and 23) in bottom.
9. Fit piston rod (29), lower piston (30) and bottom (21).
10. Mount the three parts.
11. Fit retaining ring (24).
12. Fit cover disk (25).
13. Mount intermediate piece (37) on actuator.
14. Fit and tighten nuts (36) and washers (35).



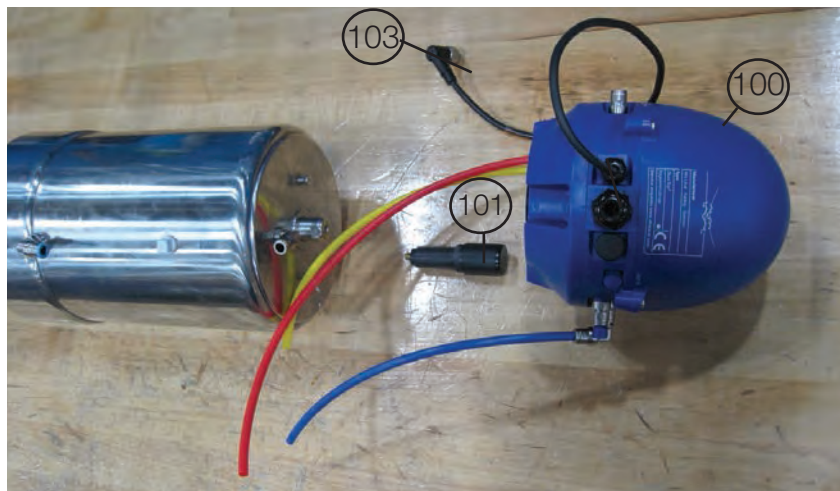
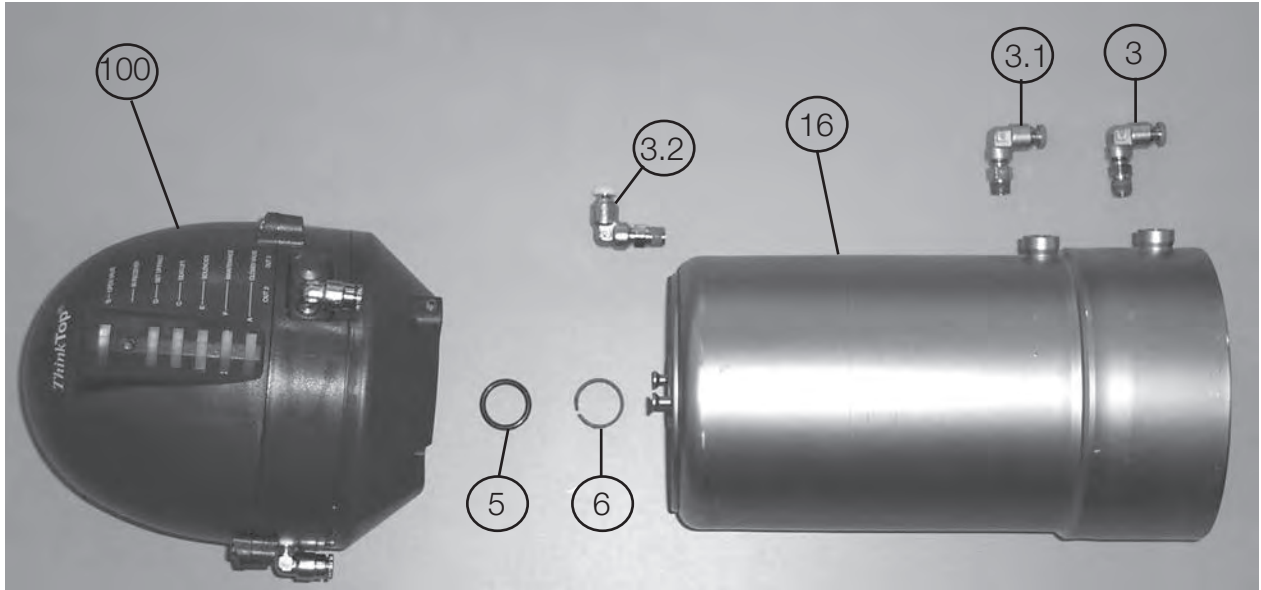

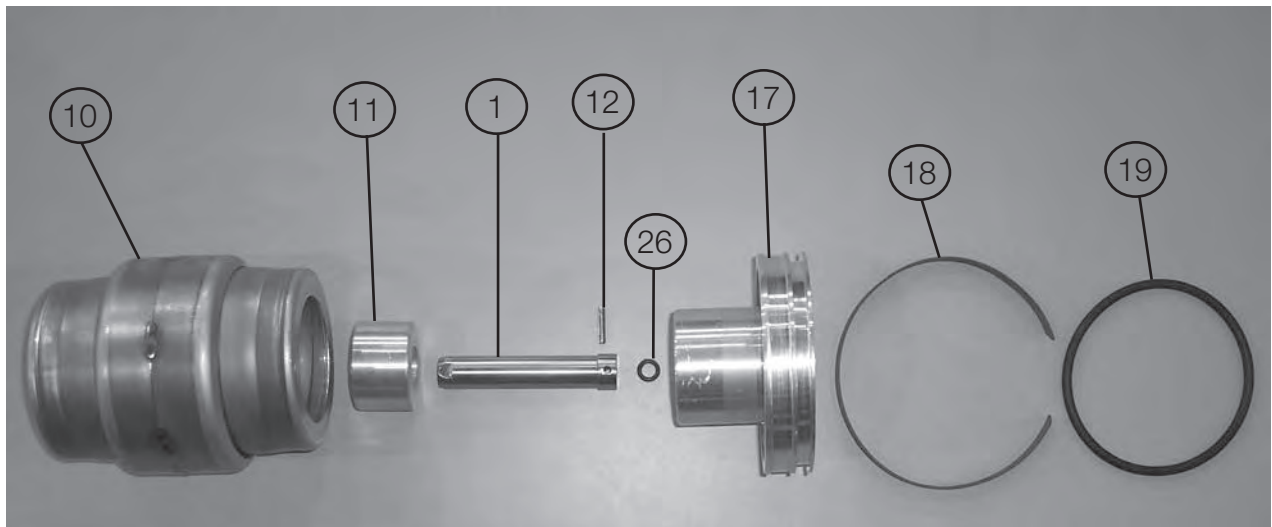
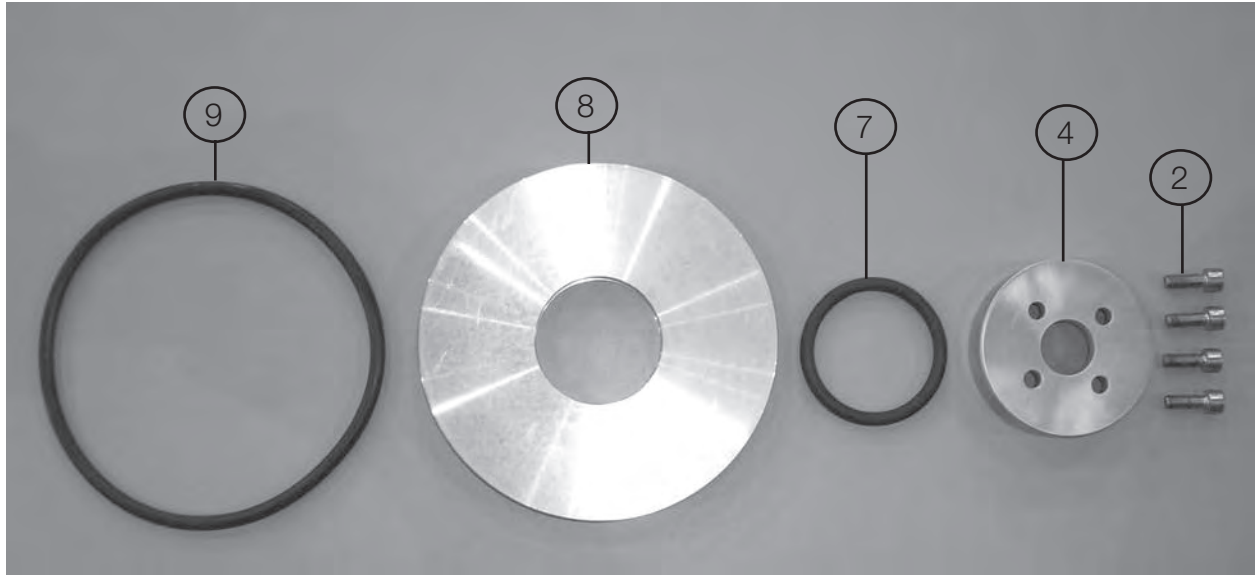

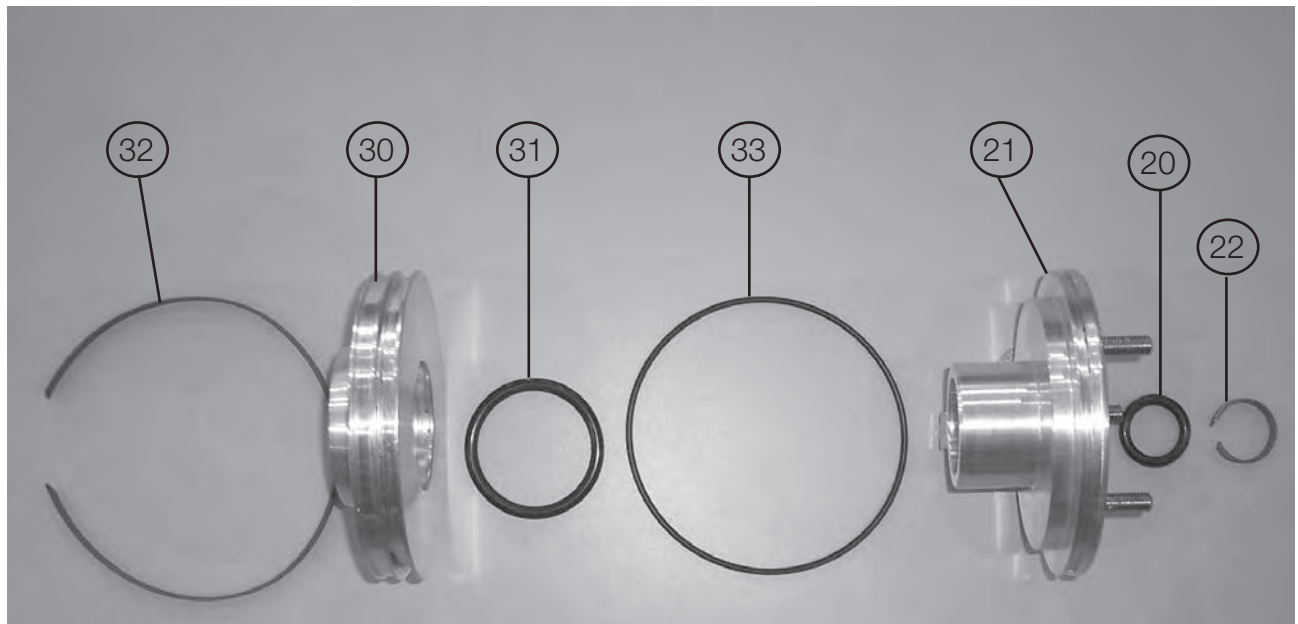
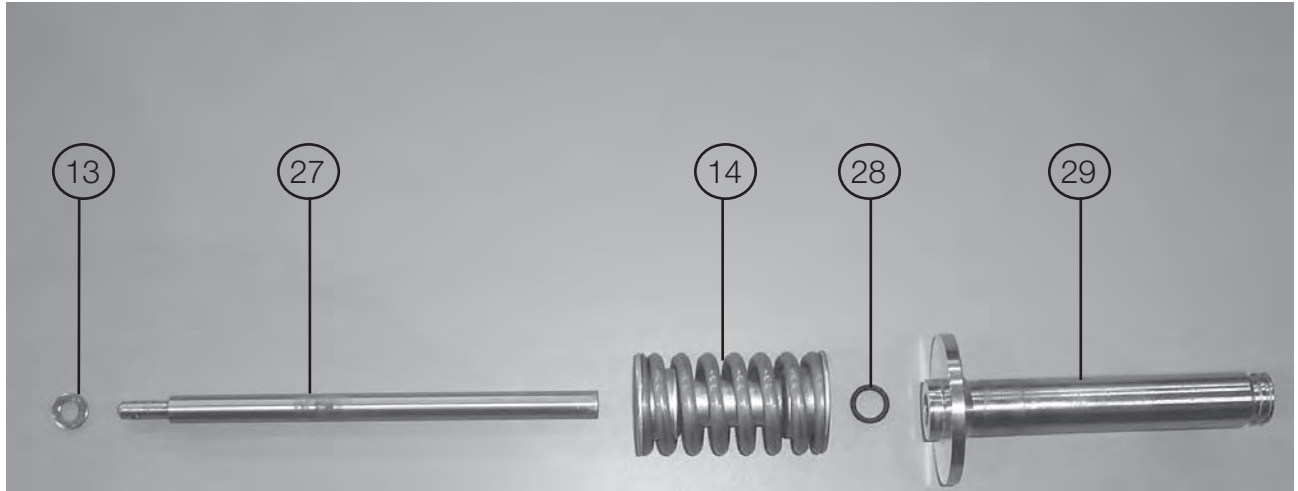

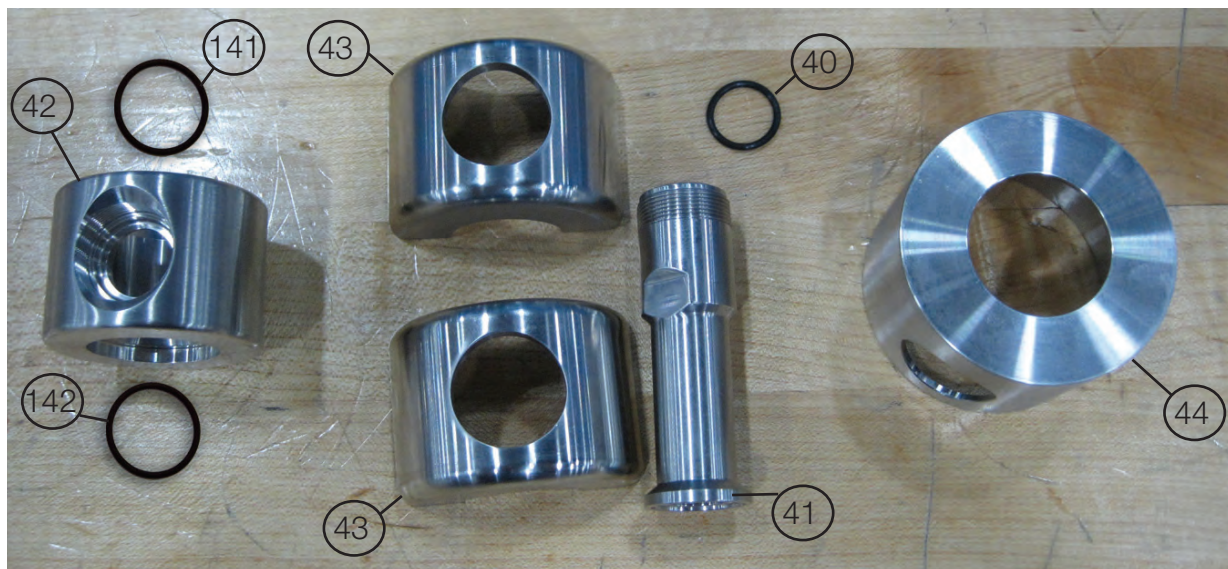

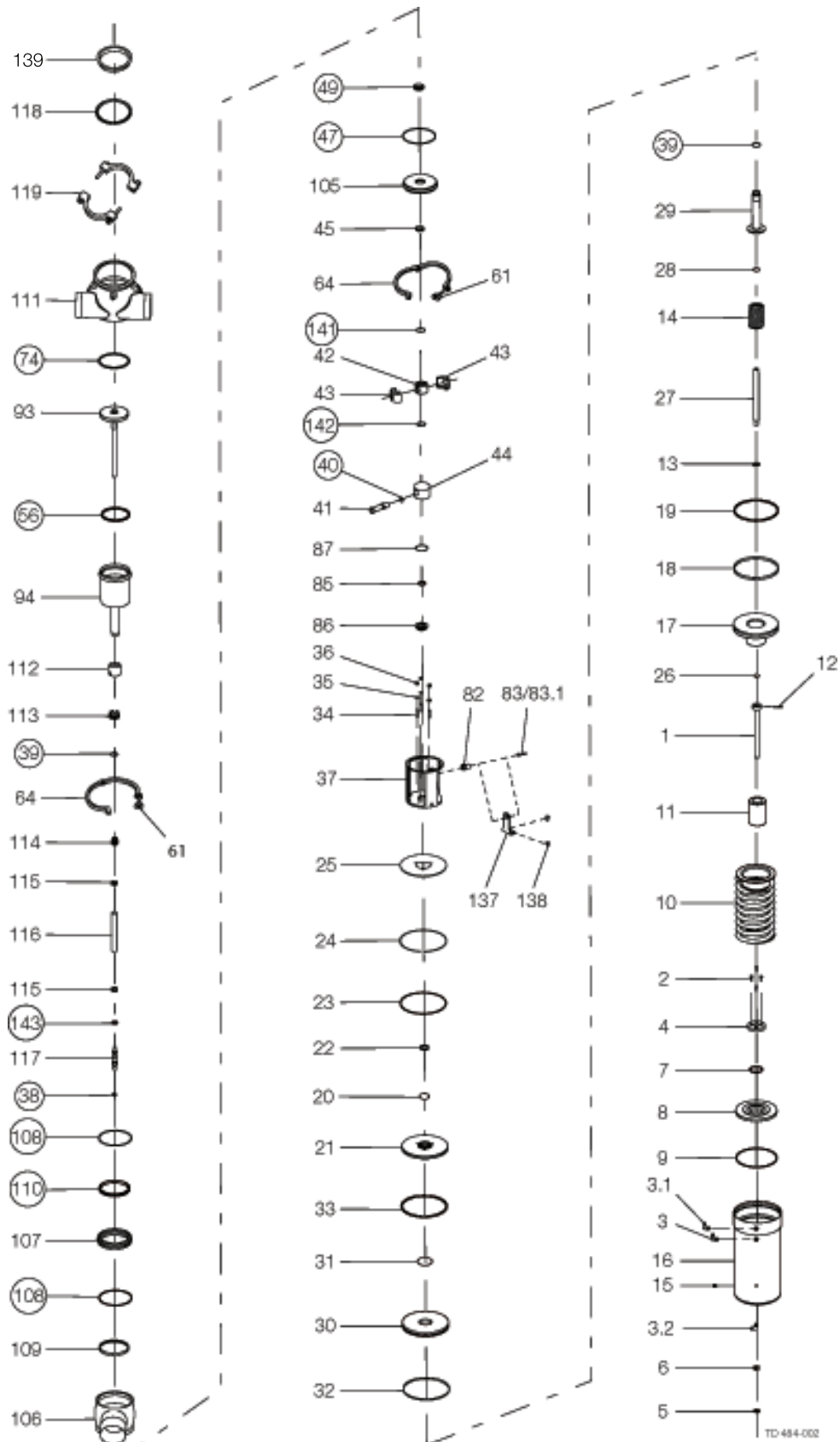

### Parts Unique PMO Plus CP HT

| Pos  | Qty | Demonination          | PMO 2½"      | PMO 3"       | PMO 4"       | PMO 6"<br>(stroke 2.95") | PMO 6"<br>(stroke 2.32") |
|------|-----|-----------------------|--------------|--------------|--------------|--------------------------|--------------------------|
| 1    | 1   | Cpl. Actuator         | 9613-0995-25 | 9613-0995-25 | 9613-4890-52 | 9613-4890-52             | 9613-4890-56             |
|      |     | Upper stem            | 9613-0074-06 | 9613-0074-06 | 9613-0074-05 | 9613-0074-05             | 9613-0074-05             |
| 2    | 4   | Screw                 | 9611-99-3342 | 9611-99-3342 | 9611-99-0144 | 9611-99-0144             | 9611-99-3342             |
| 3    | 1   | Air fitting yellow    | 9611-99-4171 | 9611-99-4171 | 9611-99-4171 | 9611-99-4171             | 9611-99-4171             |
|      | 1   | Air fitting blue      | 9611-99-3780 | 9611-99-3780 | 9611-99-3780 | 9611-99-3780             | 9611-99-3780             |
|      | 1   | Air fitting red       | 9611-99-4172 | 9611-99-4172 | 9611-99-4172 | 9611-99-4172             | 9611-99-4172             |
| 4    | 1   | Stop for upper piston | 9613-0053-01 | 9613-0053-01 | 9613-4883-01 | 9613-4883-01             | 9613-0053-01             |
| 5    | 1   | O-ring, NBR           | 9611-99-3499 | 9611-99-3499 | 9611-99-3499 | 9611-99-3499             | 9611-99-3499             |
| 6    | 1   | Guide ring, Turcite   | 9613-0084-08 | 9613-0084-08 | 9613-0084-08 | 9613-0084-08             | 9613-0084-08             |
| 7    | 1   | O-ring, NBR           | 9611-99-5099 | 9611-99-5099 | 9611-99-5099 | 9611-99-5099             | 9611-99-5099             |
| 8    | 1   | Upper piston          | 9614-0321-01 | 9614-0321-01 | 9614-0321-02 | 9614-0321-02             | 9614-0321-02             |
| 9    | 1   | O-ring, NBR           | 9611-99-5097 | 9611-99-5097 | 9611-99-5097 | 9611-99-5097             | 9611-99-5097             |
| 10   | 1   | Spring assembly       | 9613-0075-01 | 9613-0075-01 | 9613-0256-07 | 9613-0256-07             | 9613-0256-06             |
| 11   | 1   | Distance spacer       |              |              | 9613-0102-07 | 9613-0102-07             | 9613-0102-07             |
| 12   | 1   | Pin                   | 9611-99-4198 | 9611-99-4198 | 9611-99-4199 | 9611-99-4199             | 9611-99-4199             |
| 13   | 1   | Washer                | 9611-99-3595 | 9611-99-3595 | 9611-99-3596 | 9611-99-3596             | 9611-99-3596             |
| 14   | 1   | Spring assembly       | 9613-0095-04 | 9613-0095-04 | 9613-0095-04 | 9613-0095-04             | 9613-0095-04             |
| 15   | 1   | Plug                  | 9613-4141-01 | 9613-4141-01 | 9613-4141-01 | 9613-4141-01             | 9613-4141-01             |
| 16   | 1   | Cylinder (3A marking) | 9613-0051-12 | 9613-0051-12 | 9613-0150-28 | 9613-0150-28             | 9613-0150-28             |
| 17   | 1   | Main piston           | 9614-0322-01 | 9614-0322-01 | 9614-0322-02 | 9614-0322-02             | 9614-0322-02             |
| 18   | 1   | Guide ring, Turcite   | 9613-0084-10 | 9613-0084-10 | 9613-0084-11 | 9613-0084-11             | 9613-0084-11             |
| 19   | 1   | O-ring, NBR           | 9611-99-3507 | 9611-99-3507 | 9611-99-3509 | 9611-99-3509             | 9611-99-3509             |
| 20   | 1   | O-ring, NBR           | 9611-99-3607 | 9611-99-3607 | 9611-99-3607 | 9611-99-3607             | 9611-99-3607             |
| 21   | 1   | Bottom                | 9613-0054-01 | 9613-0054-01 | 9613-0168-01 | 9613-0168-01             | 9613-0168-01             |
| 22   | 1   | Guide ring, Turcite   | 9613-0084-04 | 9613-0084-04 | 9613-0084-04 | 9613-0084-04             | 9613-0084-04             |
| 23   | 1   | O-ring, NBR           | 9611-99-1489 | 9611-99-1489 | 22340675     | 22340675                 | 22340675                 |
| 24   | 1   | Retaining ring        | 9613-0248-03 | 9613-0248-03 | 9613-0248-04 | 9613-0248-04             | 9613-0248-04             |
| 25   | 1   | Cover disk            | 9613-0058-03 | 9613-0058-03 | 9613-0058-04 | 9613-0058-04             | 9613-0058-04             |
| 26   | 1   | O-ring, NBR           | 9611-99-3495 | 9611-99-3495 | 9611-99-3530 | 9611-99-3530             | 9611-99-3530             |
| 27   | 1   | Inner stem            | 9613-0073-01 | 9613-0073-01 | 9613-0073-05 | 9613-0073-05             | 9613-0073-05             |
| 28   | 1   | O-ring                | 9611-99-0030 | 9611-99-0030 | 9611-99-0030 | 9611-99-0030             | 9611-99-0030             |
| 29   | 1   | Piston rod            | 9613-0060-06 | 9613-0060-06 | 9613-0060-05 | 9613-0060-05             | 9613-0060-05             |
| 30   | 1   | Lower piston          | 9613-0055-01 | 9613-0055-01 | 9613-0166-01 | 9613-0166-01             | 9613-0166-01             |
| 31   | 1   | O-ring, NBR           | 42153        | 42153        | 42153        | 42153                    | 42153                    |
| 32   | 1   | Guide ring, Turcite   | 9613-0084-06 | 9613-0084-06 | 9613-0084-07 | 9613-0084-07             | 9613-0084-07             |
| 33   | 1   | O-ring, NBR           | 9611-99-3508 | 9611-99-3508 | 9611-99-3510 | 9611-99-3510             | 9611-99-3510             |
| 34   | 3   | Bolt                  | 9611-99-3618 | 9611-99-3618 | 9611-99-3618 | 9611-99-3618             | 9611-99-3618             |
| 35   | 2   | Washer                | 9611-99-3594 | 9611-99-3594 | 9611-99-3594 | 9611-99-3594             | 9611-99-3594             |
| 35.1 | 1   | Washer                | 9611-99-2559 | 9611-99-2559 | 9611-99-2559 | 9611-99-2559             | 9611-99-2559             |
| 36   | 3   | Nut                   | 9611-99-0360 | 9611-99-0360 | 9611-99-0360 | 9611-99-0360             | 9611-99-0360             |

continued on next page...



**Parts Unique PMO Plus CP HT** continued from previous page

| Pos  | Qty | Demonination                    | PMO 2½"      | PMO 3"       | PMO 4"       | PMO 6"<br>(stroke 2.95") | PMO 6"<br>(stroke 2.32") |
|------|-----|---------------------------------|--------------|--------------|--------------|--------------------------|--------------------------|
| 41   | 1   | Flushing tube                   | 9614-0308-01 | 9614-0308-01 | 9614-0308-02 | 9614-0308-03             | 9614-0308-03             |
| 42   | 1   | Spindle liner                   | 9614-0307-01 | 9614-0307-01 | 9614-0307-01 | 9614-0319-01             | 9614-0319-01             |
| 43   | 2   | Clamp                           | 9614-0306-01 | 9614-0306-01 | 9614-0306-01 | 9614-0318-01             | 9614-0318-01             |
| 44   | 1   | Lock                            | 9614-0305-01 | 9614-0305-01 | 9614-0305-01 | 9614-0305-01             | 9614-0305-01             |
| 45   | 1   | Guide ring, PTFE                | 9613-0084-17 | 9613-0084-17 | 9613-0084-17 | 9613-0084-12             | 9613-0084-12             |
| 61   | 2   | Wingnut                         | 9612-5580-01 | 9612-5580-01 | 9612-5580-01 | 9613-1495-01             | 9613-1495-01             |
| 64   | 2   | Clamp without nut               | 9613-0216-01 | 9613-0216-01 | 9614-0766-01 | 9613-4884-01             | 9613-4884-01             |
| 82   | 1   | Bolt for indication             | 9613-0926-03 | 9613-0926-03 | 9613-0926-03 | 9613-0926-03             | 9613-0926-03             |
| 83   | 1   | Sensor for indication           | 9611-99-4916 | 9611-99-4916 | 9611-99-4916 | 9611-99-4916             | 9611-99-4916             |
| 83.1 | 1   | Cable for sensor for indication | 9611-99-4915 | 9611-99-4915 | 9611-99-4915 | 9611-99-4915             | 9611-99-4915             |
| 84   | 1   | Plate for sensor for indication | 9613-0957-01 | 9613-0957-01 | 9613-0957-01 | 9613-0957-01             | 9613-0957-01             |
| 85   | 1   | O-ring                          | 9611-99-0092 | 9611-99-0092 | 9611-99-0092 | 9611-99-0092             | 9611-99-0092             |
| 86   | 1   | Plug for actuator               | 9613-0990-02 | 9613-0990-02 | 9613-0990-02 | 9613-0990-02             | 9613-0990-02             |
| 87   | 1   | O-ring                          | 9611-99-4599 | 9611-99-4599 | 9611-99-4599 | 9611-99-4599             | 9611-99-4599             |
| 93   | 1   | Tank plug                       | 9614-0079-01 | 9614-0066-01 | 9614-0082-01 | 9614-0085-01             | 9614-0085-01             |
| 94   | 1   | Balance plug                    | 9614-0107-01 | 9614-0093-01 | 9614-0110-01 | 9614-0113-01             | 9614-0113-01             |
| 105  | 1   | Upper sealing element           | 9613-0064-03 | 9613-0064-03 | 9613-0188-03 | 9614-0011-01             | 9614-0011-01             |
| 107  | 1   | Sealing element                 | 9614-0013-01 | 9614-0013-01 | 9614-0014-01 | 9614-0015-01             | 9614-0015-01             |
| 109  | 1   | Guide ring, PTFE                | 9613-4661-08 | 9613-4661-08 | 9613-4661-09 | 9613-4661-10             | 9613-4661-10             |
| 112  | 1   | Rotating nozzle                 | 9614-0101-01 | 9614-0101-01 | 9614-0101-01 | 9614-0117-01             | 9614-0117-01             |
| 113  | 1   | Lockring rotating nozzle        | 9614-0102-01 | 9614-0102-01 | 9614-0102-01 | 9614-0118-01             | 9614-0118-01             |
| 114  | 1   | Rotating nozzle                 | 9614-0071-01 | 9614-0071-01 | 9614-0071-01 | 9614-0089-01             | 9614-0089-01             |
| 115  | 2   | Guidering rotating nozzle       | 9614-0072-01 | 9614-0072-01 | 9614-0072-01 | 9614-0090-01             | 9614-0090-01             |
| 116  | 1   | Pipe                            | 9614-0073-02 | 9614-0073-03 | 9614-0073-04 | 9614-0073-05             | 9614-0073-05             |
| 117  | 1   | Spindle                         | 9614-0074-01 | 9614-0074-01 | 9614-0074-01 | 9614-0091-01             | 9614-0091-01             |
| 119  | 1   | Clamp                           | 210042       | 210042       | 9634-0489-82 | 9634-0852-94             | 9634-0852-94             |
| 137  | 1   | Indication bracket              | N/A          | N/A          | N/A          | 9614-0464-01             | 9614-0464-01             |
| 138  | 2   | Screw for indication bracket    | N/A          | N/A          | N/A          | 9611-99-2105             | 9611-99-2105             |
| 139  | 1   | Clamp ferrule                   | 610373       | 610373       | 9634-0499-38 | 660-026                  | 660-026                  |

**Parts *Unique* PMO Plus CP HT**

| Pos. | Qty. | Denomination               | PMO 2½"      | PMO 3"       | PMO 4"       | PMO 6"       |
|------|------|----------------------------|--------------|--------------|--------------|--------------|
| 37   | 1    | Intermediate piece         | 9613-0191-23 | 9613-0191-23 | 9613-0192-17 | 9613-4966-03 |
| 111  | 1    | Valve body TL, clamp end   | 9614-0050-01 | 9614-0053-01 | 9614-0056-01 | 9614-0059-01 |
|      | 1    | Valve body TR, clamp end   | 9614-0050-02 | 9614-0053-02 | 9614-0056-02 | 9614-0059-02 |
|      | 1    | Valve body TC, clamp end   | 9614-0050-03 | 9614-0053-03 | 9614-0056-03 | 9614-0059-03 |
|      | 1    | Valve body TL, welding end | 9614-0050-04 | 9614-0053-04 | 9614-0056-04 | 9614-0059-04 |
|      | 1    | Valve body TR, welding end | 9614-0050-05 | 9614-0053-05 | 9614-0056-05 | 9614-0059-05 |
|      | 1    | Valve body TC, welding end | 9614-0050-06 | 9614-0053-06 | 9614-0056-06 | 9614-0059-06 |
| 106  | 1    | Vent body                  | 9614-0019-01 | 9614-0022-01 | 9614-0025-01 | 9614-0028-01 |

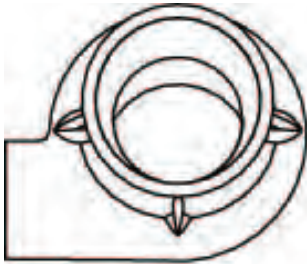

**TR**

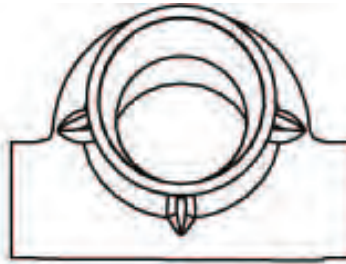

**TC**

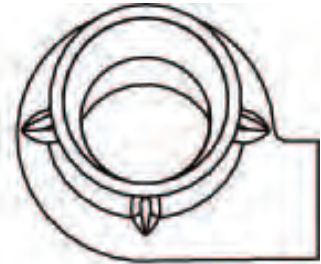

**TL**

**Seen from tank connection side.**



## Parts

| Pos. | Qty. | Denomination                             | 2½" and 3"   | 4" and 6"    |
|------|------|--|--------------|--------------|
| 100  | 1    | ThinkTop Complete (8-30VDC, 0-Solenoids) | 9612-5789-66 | 9612-5789-66 |
| 100  | 1    | ThinkTop Complete (8-30VDC, 3-Solenoids) | 9612-5789-69 | 9612-5789-69 |
| 100  | 1    | ThinkTop Complete (110VAC, 0-Solenoids)  | 9612-9906-66 | 9612-9906-66 |
| 100  | 1    | ThinkTop Complete (110VAC, 3-Solenoids)  | 9612-9906-69 | 9612-9906-69 |
| 101  | 1    | Magnet, ThinkTop                         | 9612-5623-01 | 9614-0794-01 |
| 83   | 1    | *Sensor (24VDC)                          | 9611-99-4916 | 9611-99-4916 |
| 83   | 1    | **Sensor (110VAC)                        | 9613-6036-42 | 9613-6036-42 |
| 82   | 1    | Nylon Plug (24VDC Sensors)               | 9613-0926-03 | 9613-0926-03 |
| 82   | 1    | Nylon Plug (110VAC Sensors)              | 9613-0926-03 | 9613-0926-03 |
| 103  | 1    | Cable (ext. sensor, 24VDC)               | 9611-99-4913 | 9611-99-4913 |
| 103  | 1    | Cable (ext. sensor, 110VAC)              | 9613-6036-43 | 9613-6036-43 |

Optional:

| Pos | Qty. | Denomination     | 2½", 3", 4" and 6" |
|-----|------|------------------|--------------------|
| 102 | 1    | Air Pilot Switch | 9613-6018-13       |

\*Sensor Used: IFM IFB3007-APKG/M/V4A/US-102-DPO (3-wire, PNP, DC, N.C., Micro-disconnect)

\*\*Sensor Used: Turck BI4-S12-RDZ32X-0.2M-SBV3T/S1023 (2-wire, PNP, AC, N.C., Micro-disconnect)

### Unique PMO Plus CP HT Wear Parts

| Pos | Qty. | Denomination                   | 2½" and 3"   | 4"           | 6"           |
|-----|------|--------------------------------|--------------|--------------|--------------|
| 38  | 1    | O-ring, EPDM                   | 9611-99-2671 | 9611-99-2671 | 9611-99-5160 |
| 39  | 2    | O-ring, EPDM                   | 9611-99-3493 | 9611-99-3493 | 9611-99-3493 |
| 40  | 1    | O-ring, EPDM                   | 9611-99-2671 | 9611-99-2671 | 9611-99-2671 |
| 47  | 1    | O-ring, EPDM (Standard)        | 9611-99-3636 | 9611-99-3640 | 9611-99-5003 |
|     | 1    | O-ring, NBR                    | 9611-99-3637 | 9611-99-3641 | 9611-99-5004 |
|     | 1    | O-ring, HNBR                   | 9611-99-3639 | 9611-99-3643 | 9611-99-5006 |
|     | 1    | O-ring, FPM                    | 9611-99-3638 | 9611-99-3642 | 9611-99-5005 |
| 49  | 1    | Lip seal, EPDM (Standard)      | 9613-0085-11 | 9613-0085-11 | 9613-0085-16 |
|     | 1    | Lip seal, NBR                  | 9613-0085-12 | 9613-0085-12 | 9613-0085-44 |
|     | 1    | Lip seal; HNBR                 | 9613-0085-14 | 9613-0085-14 | 9613-0085-19 |
|     | 1    | Lip seal, FPM                  | 9613-0085-13 | 9613-0085-13 | 9613-0085-18 |
| 56  | 1    | Seal ring, EPDM (Standard)     | 9613-0951-09 | 9613-0951-12 | 9613-0951-47 |
|     | 1    | Seal ring, NBR                 | 9613-0951-15 | 9613-0951-16 | 9613-0951-48 |
|     | 1    | Seal ring, HNBR                | 9613-0951-07 | 9613-0951-10 | 9613-0951-45 |
|     | 1    | Seal ring, FPM                 | 9613-0951-08 | 9613-0951-11 | 9613-0951-46 |
| 74  | 1    | Seal ring, EPDM (Standard)     | 9613-0952-09 | 9613-0952-12 | 9613-0952-47 |
|     | 1    | Seal ring, NBR                 | 9613-0952-15 | 9613-0952-16 | 9613-0952-48 |
|     | 1    | Seal ring, HNBR                | 9613-0952-07 | 9613-0952-10 | 9613-0952-45 |
|     | 1    | Seal ring, FPM                 | 9613-0952-08 | 9613-0952-11 | 9613-0952-46 |
| 108 | 2    | O-ring, EPDM (Standard)        | 9611-99-3636 | 9611-99-3640 | 9611-99-5003 |
|     | 2    | O-ring, NBR                    | 9611-99-3637 | 9611-99-3641 | 9611-99-5004 |
|     | 2    | O-ring, HNBR                   | 9611-99-3639 | 9611-99-3643 | 9611-99-5006 |
|     | 2    | O-ring, FPM                    | 9611-99-3638 | 9611-99-3642 | 9611-99-5005 |
| 110 | 1    | Lip seal, EPDM (Standard)      | 9613-0085-26 | 9613-0085-31 | 9613-0085-60 |
|     | 1    | Lip seal, NBR                  | 9613-0085-46 | 9613-0085-47 | 9613-0085-65 |
|     | 1    | Lip seal; HNBR                 | 9613-0085-29 | 9613-0085-34 | 9613-0085-63 |
|     | 1    | Lip seal, FPM                  | 9613-0085-28 | 9613-0085-33 | 9613-0085-62 |
| 118 | 1    | Clamp packing, EPDM (Standard) | 290025       | 290131       | 290226       |
|     | 1    | Clamp packing, NBR             | 298349       | 298220       | 298222       |
|     | 1    | Clamp packing, HNBR            | 290172       | 290182       | 290237       |
|     | 1    | Clamp packing, FPM             | 290172       | 290182       | 290237       |
| 141 | 1    | O-ring, EPDM                   | 9611-99-3493 | 9611-99-3493 | 9611-99-3493 |
| 142 | 1    | O-ring, EPDM                   | 9611-99-3493 | 9611-99-3493 | 9611-99-5347 |
| 143 | 1    | O-ring, EPDM                   | 9611-99-5345 | 9611-99-5345 | 9611-99-5346 |

### Service Kit for Product Wetted Parts (Unique PMO Plus CP HT)

| Denomination | 2½" and 3"   | 4"           | 6"           |
|--------------|--------------|--------------|--------------|
| EPDM         | 9611-92-6881 | 9611-92-6885 | 9611-92-6889 |
| NBR          | 9611-92-6882 | 9611-92-6886 | 9611-92-6890 |
| HNBR         | 9611-92-6883 | 9611-92-6887 | 9611-92-6891 |
| FPM          | 9611-92-6884 | 9611-92-6888 | 9611-92-6892 |

**Axial Installation Tool**

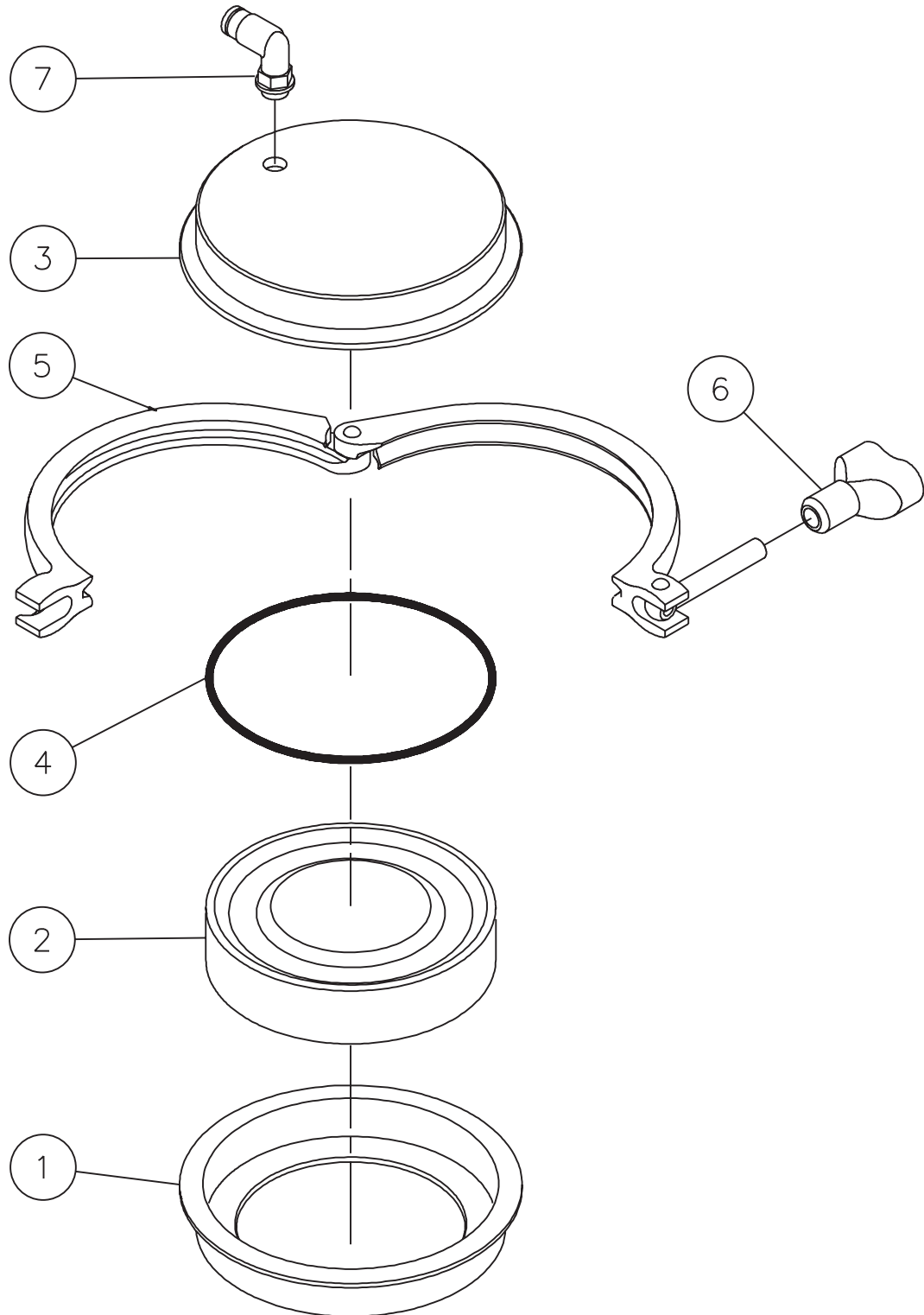

### Axial Installation Tool

| 2½"          | 3"           | 4"           | 6"           |
|--------------|--------------|--------------|--------------|
| 9613-0505-02 | 9614-0792-01 | 9613-0505-06 | 9613-0505-10 |

| Pos. | Qty. | Denomination | 2½" and 3"   | 4"           | 6"           |
|------|------|--------------|--------------|--------------|--------------|
| 1    | 1    | Lower Part   |              |              |              |
| 2    | 1    | Piston       |              |              |              |
| 3    | 1    | Upper part   |              |              |              |
| 4    | 1    | O-ring, NBR  | 9611-99-3703 | 9611-99-3349 | 9611-99-5169 |
| 5    | 1    | Clamp        |              |              |              |
| 6    | 1    | Wingnut      |              |              |              |
| 7    | 1    | Air fitting  |              |              |              |

**Radial Installation Tool**

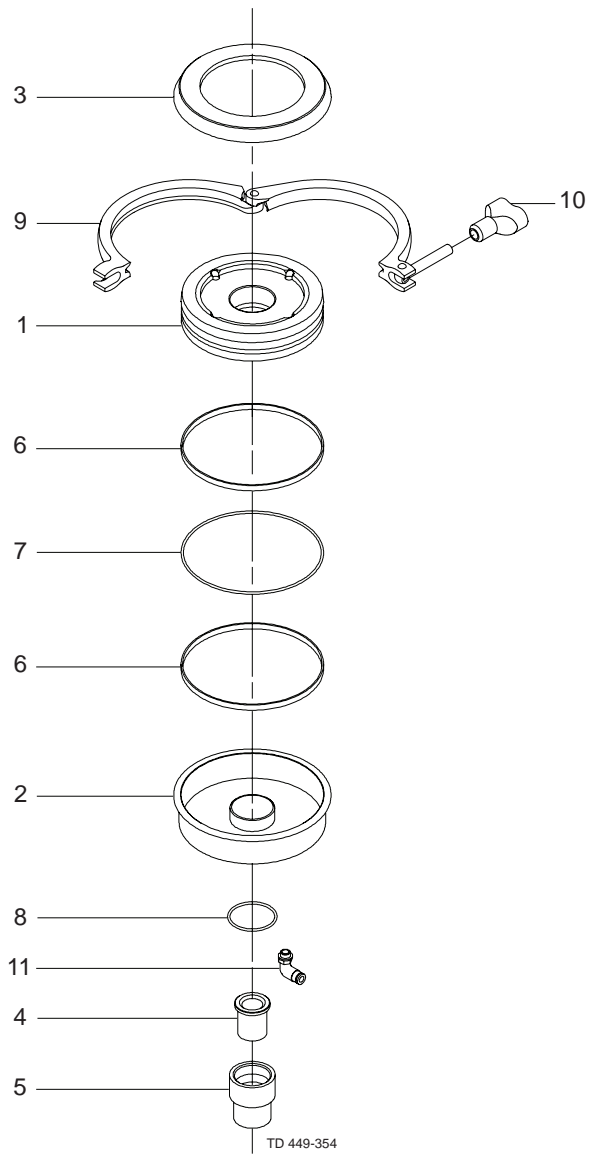

### Radial Installation Tool

| 2½" and 3"   | 4"           | 6"           |
|--------------|--------------|--------------|
| 9614-0788-01 | 9614-0788-02 | 9614-0788-03 |

| Pos. | Qty. | Denomination | 2½" and 3" | 4"           | 6"           |
|------|------|--------------|------------|--------------|--------------|
| 1    | 1    | Piston       |            |              |              |
| 2    | 1    | Lower Part   |            |              |              |
| 3    | 1    | Upper Part   |            |              |              |
| 4    | 1    | Bushing      |            |              |              |
| 5    | 1    | Guide        |            |              |              |
| 6    | 2    | Guide Ring   |            | 9613-0084-22 | 9613-0084-30 |
| 7    | 1    | O-Ring       |            | 9611-99-3349 | 9611-99-5169 |
| 8    | 1    | O-Ring       |            | 9611-99-3705 |              |
| 9    | 1    | Clamp        |            |              |              |
| 10   | 1    | Wingnut      |            |              |              |
| 11   | 1    | Air fitting  |            |              |              |

**Alfa Laval**

9560 - 58th Place, Suite 300

Kenosha, WI 53144

USA

Tel: 262-605-2600

Fax: 262-605-2667



The information herein is correct at the time of issue, but may be subject to change without prior notice. © 2012 Alfa Laval Inc.



[www.alfalaval.us](http://www.alfalaval.us)