

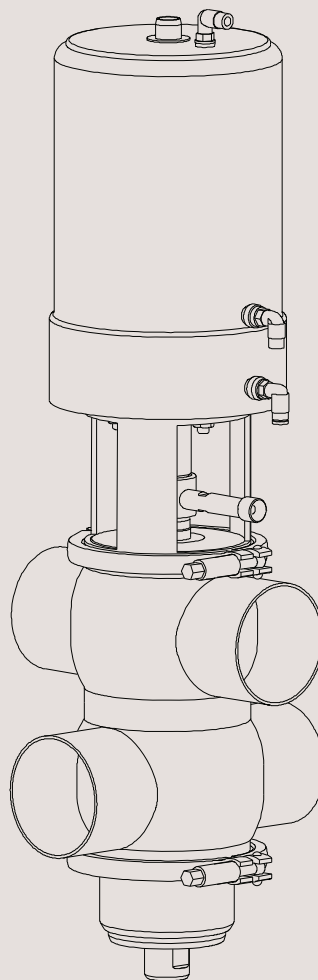

# Instruction Manual

## Unique Sanitary Mixproof Valve (including US version)



TD 449-006\_1

ESE00923-EN8 2015-xx

Original manual



The information herein is correct at the time of issue but may be subject to change without prior notice

<b>1. Declaration of Conformity</b> .....	<b>4</b>
<b>2. Safety</b> .....	<b>5</b>
2.1. Important information .....	5
2.2. Warning signs .....	5
2.3. Safety precautions .....	6
<b>3. Installation</b> .....	<b>7</b>
3.1. Unpacking/intermediate storage .....	7
3.2. General information .....	9
3.3. Welding .....	11
3.4. Recycling information .....	15
<b>4. Operation</b> .....	<b>16</b>
4.1. Operation .....	16
4.2. Fault finding and repair .....	17
4.3. Recommended cleaning .....	18
<b>5. Maintenance</b> .....	<b>21</b>
5.1. General maintenance .....	21
5.2. Dismantling the valve .....	23
5.3. Lower plug, replacement of radial seal .....	25
5.4. Upper plug, replacement of axial seal .....	27
5.5. Assembly of valve .....	29
5.6. Dismantling of actuator .....	32
5.7. Assembly of actuator .....	33
<b>6. Technical data</b> .....	<b>34</b>
6.1. Technical data .....	34
<b>7. Parts list and service kits</b> .....	<b>36</b>
7.1. Four configurations examples .....	36
7.2. Wear parts .....	38
7.3. Parts .....	42
7.4. Service kits (plug set-up 1-4) .....	45
7.5. Service kits (plug set-up 5-8) .....	47
7.6. Service kits (plug set-up 9-12) .....	49
7.7. Service kits (plug set-up 13-16) .....	51
7.8. Service kits - mix with DN125, DN150, Sch. 5 5" and Sch. 5 6" (plug set-up 1-4) .....	53
7.9. Service kits - mix with DN125, DN150, Sch. 5 5" and Sch. 5 6" (plug set-up 5-8) .....	55
7.10. Service kits - mix with DN125, DN150, Sch. 5 5" and Sch. 5 6" (plug set-up 9-12) .....	57
7.11. Service kits - mix with DN125, DN150, Sch. 5 5" and Sch. 5 6" (plug set-up 13-16) .....	59
7.12. Axial installation tool .....	61
7.13. Radial installation tool .....	63

# 1 Declaration of Conformity

Revision of Declaration of Conformity 2009-12-29

The Designated Company

Alfa Laval Kolding A/S

Company Name

Albuen 31, DK-6000 Kolding, Denmark

Address

+45 79 32 22 00

Phone No.

hereby declare that

Valve

Designation

Unique std.

Type

From serial number 1181354 - 9999999

is in conformity with the following directive with amendments:

- Machinery Directive 2006/42/EC
- Regulation (EC) No 1935/2004
- The valve is in compliance with the Pressure Equipment Directive 97/23/EC and was subjected to the following assessment procedure Module A. Diameters  $\geq$  DN125 may not be used for fluids group 1.

The person authorised to compile the technical file is the signer of this document

QHSE Manager, Quality, Health and safety & Environment

Title

Annie Dahl

Name

Kolding

Place

2000-01-01

Date



Signature



---

*Unsafe practices and other important information are emphasized in this manual.  
Warnings are emphasized by means of special signs.*

---

### 2.1 Important information

---

**Always read the manual before using the Valve!**

#### **WARNING**

Indicates that special procedures must be followed to avoid serious personal injury.

#### **CAUTION**

Indicates that special procedures must be followed to avoid damage to the valve.

#### **NOTE**

Indicates important information to simplify or clarify procedures.

---

### 2.2 Warning signs

---

General warning:



Caustic agents:



Cutting danger:



## 2 Safety

---

All warnings in the manual are summarized on this page.

Pay special attention to the instructions below so that severe personal injury and/or damage to the valve are avoided.

---

### 2.3 Safety precautions

---

#### Installation:

**Always** read the technical data thoroughly (see chapter 6.1 Technical data) 

**Always** release compressed air after use



**Never** touch the clip assembly or the actuator piston rod if the actuator is supplied with compressed air (see warning label)

**Never** stick your fingers through the valve ports if the actuator is supplied with compressed air 

---

#### Operation:

**Always** read the technical data thoroughly (see chapter 6.1 Technical data)

**Never** touch the clip assembly or the actuator piston rod when the actuator is supplied with compressed air (see warning label)  

**Never** pressurise air connections (AC1, AC3) simultaneously as both valve plugs can be lifted (can cause mixing)  
**Never** touch the valve or the pipelines when processing hot liquids or when sterilizing.

**Never** throttle the leakage outlet

**Never** throttle the CIP outlet, if supplied

**Always** handle lye and acid with great care 

---

#### Maintenance:

**Always** read the technical data thoroughly (see chapter 6.1 Technical data) 

**Always** fit the seals correctly

**Always** release compressed air after use

**Always** remove the CIP connections, if supplied, before service.

**Never** service the valve when it is hot

**Never** pressurise the valve/actuator when the valve is serviced

**Never** stick your fingers through the valve ports if the actuator is supplied with compressed air

**Never** touch the clip assembly or the actuator piston rod if the actuator is supplied with compressed air (see warning label) 

---

#### Transportation:

**Always** ensure that compressed air are released

**Always** ensure that all connections is disconnected before attempting to remove the valve from the installation

**Always** drain liquid out of valves before transportation

**Always** used predesigned lifting points if defined

**Always** ensure sufficient fixing of the valve during transportation - if specially designed packaging material is available, it must be used

---

The instruction manual is part of the delivery.  
Study the instructions carefully.  
Fit the warning label supplied on the valve after installation so that it is normally visible.

### 3.1 Unpacking/intermediate storage

#### Step 1

##### CAUTION

Alfa Laval cannot be held responsible for incorrect unpacking.

##### Check the delivery for:

1. Complete valve.
2. Delivery note.
3. Warning label.

#### Step 2

Remove upper support.

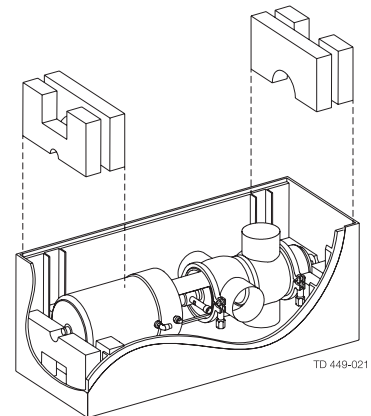

#### Step 3

Lift out the valve.

##### NOTE!

Please note weight of valve as printed on box.

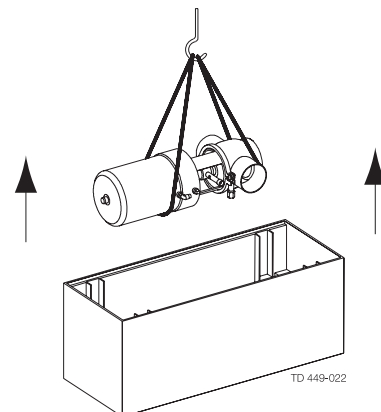

#### Step 4

Remove possible packing materials from the valve ports.

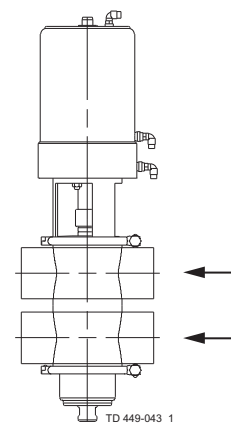

### 3 Installation

The instruction manual is part of the delivery.

Study the instructions carefully.

Fit the warning label supplied on the valve after installation so that it is normally visible.

#### Step 5

Inspect the valve for visible transport damages.

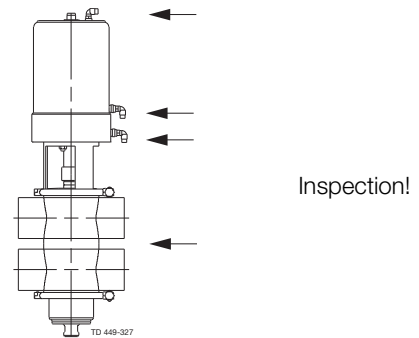

#### Step 6

Avoid damaging the air connections, the leakage outlet, the valve ports and the CIP connections, if supplied.

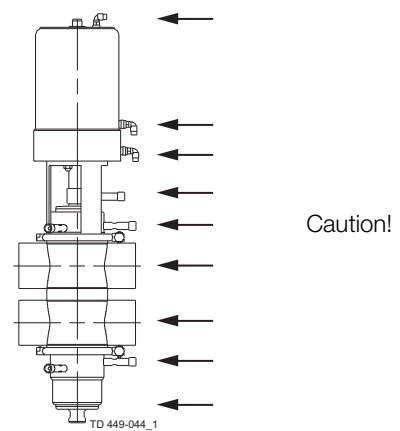

#### Step 7

Disassemble according to illustrations 1 to 6 (please also see section 5.2 Dismantling the valve).

1. Supply compressed air.
2. Remove upper clamp.
3. Release compressed air.
4. Lift out actuator with plugs.
5. Remove lower clamp.
6. Take away lower sealing element.

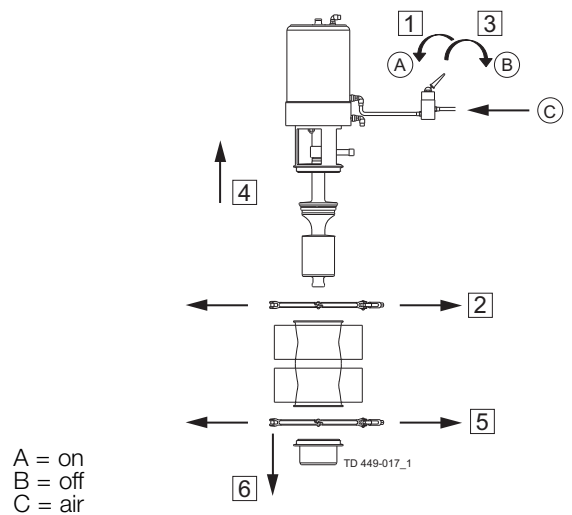

#### Step 8

Mount sealing element on valve.

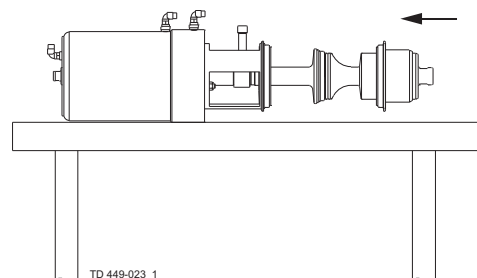



Study the instructions carefully and pay special attention to the warnings!  
The valve has ends for welding as standard but can also be supplied with fittings.

### Step 9

1. Place actuator part in the box.
2. Add supports.
3. Close box and store.

#### Advise!

Mark the valve body and box with the same number before intermediate storage.

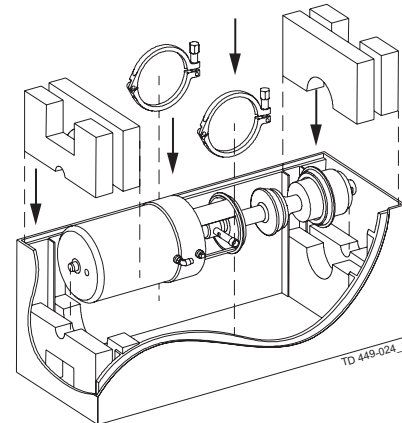

## 3.2 General information

### Step 1



**Always** read the technical data thoroughly.  
See section 6.1 Technical data



**Always** release compressed air after use.



**Never** touch the clip assembly or the actuator piston rod if the actuator is supplied with compressed air (see the warning label).

#### CAUTION

Fit the supplied warning label on the valve so that it is normally visible.  
Alfa Laval cannot be held responsible for incorrect installation.

#### NOTE

**Always** install the valve vertically.  
The leakage outlet must be turned downwards!

### Step 2

Avoid stressing the valve as this can result in deformation of the sealing area and malfunction of the valve (leakage or faulty indication).

#### Pay special attention to:

- Vibrations.
- Thermal expansion of the tubes.
- Excessive welding.
- Overloading of the pipelines.

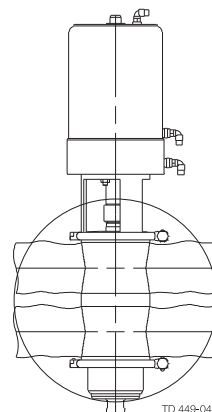

Risk of damage!

### 3 Installation

Study the instructions carefully and pay special attention to the warnings!  
The valve has ends for welding as standard but can also be supplied with fittings.

#### Step 3

Fittings: Ensure that the connections are tight.

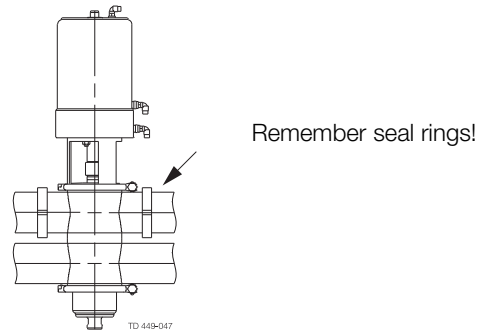

#### Step 4

Air connection: R 1/8" (BSP).  
AC1: Cleaning of upper seat.  
AC2: Open valve.  
AC3: Cleaning of lower seat.

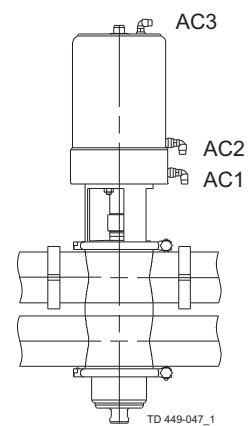

#### Step 5

CIP connection (optional extra):

1. See description of cleaning in section 4.3 Recommended cleaning.
2. Connect CIP correctly.

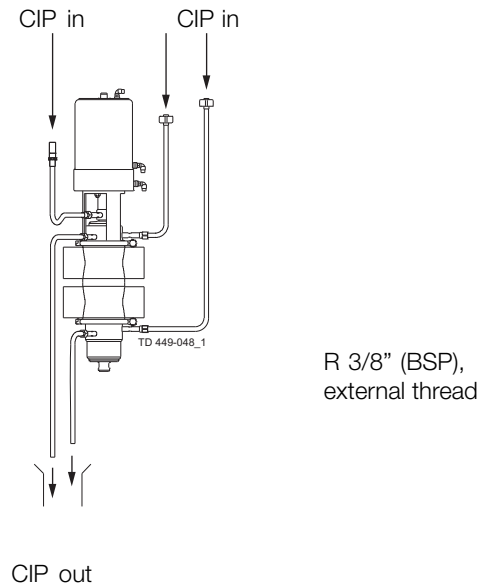

Study the instructions carefully and pay special attention to the warnings!

The valve has ends for welding as standard.

**Weld carefully/aim at stressless welding to avoid deformation on sealing areas.**

**Check the valve for smooth operation after welding.**

#### Step 6

It is important to connect CIP inlet to the small inlet nozzle to avoid built-up pressure in the cleaning chamber.

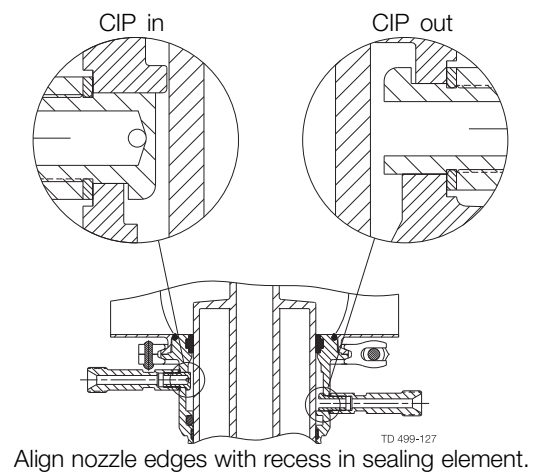

### 3.3 Welding

#### Step 1



**Never** stick your fingers through the valve ports if the actuator is supplied with compressed air.

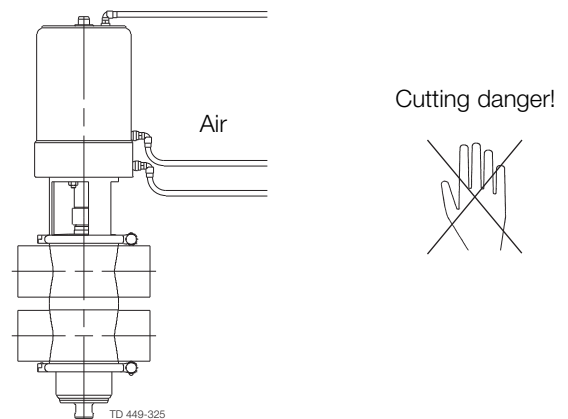

#### Step 2

Dismantle the valve in accordance with Step 1 in section 5.2 Dismantling the valve.

#### Step 3

##### NOTE

Maintain the minimum clearances so that the actuator with the internal valve parts can be removed - please see later this section!



If there is a risk of foot damage, Alfa Laval recommends to leave a distance of 120 mm (4.7") below the valve (look at the specific built-in conditions).

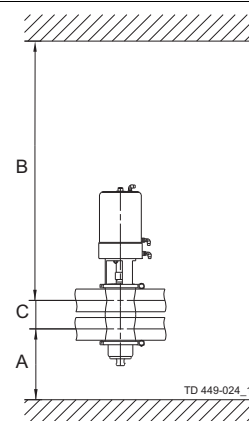

### 3 Installation

Study the instructions carefully and pay special attention to the warnings!

The valve has ends for welding as standard.

**Weld carefully/aim at stressless welding to avoid deformation on sealing areas.**

**Check the valve for smooth operation after welding.**

#### Step 4

##### WARNING

Make sure to turn the valve body correctly - conical valve seat upwards.

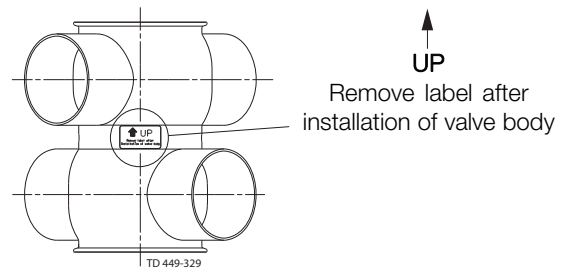

#### Step 5

Assemble the valve in accordance with section 5.5 Assembly of valve after welding.

**Pay special attention to the warnings!**

#### Step 6

##### Pre-use check:

1. Supply compressed air to AC1, AC2 and AC3 one by one.
2. Operate the valve several times to ensure that it runs smoothly.

**Pay special attention to the warnings!**

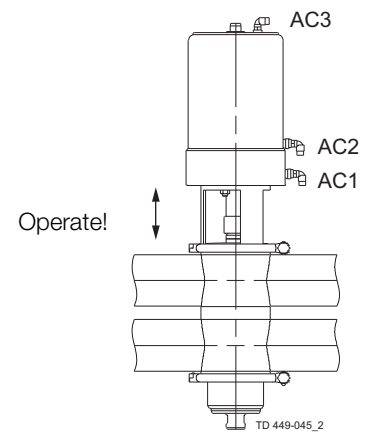

### 3 Installation

Study the instructions carefully and pay special attention to the warnings!

The valve has ends for welding as standard.

**Weld carefully/aim at stressless welding to avoid deformation on sealing areas.**

**Check the valve for smooth operation after welding.**

#### NOTE!

If ThinkTop® is mounted, add 180 mm (7,1") to B measure.

#### Table 1 and 2

1. Lower sealing element can be removed without taking out actuator and internal valve parts.
2. Actuator and internal valve parts can be lifted out of the valve body.

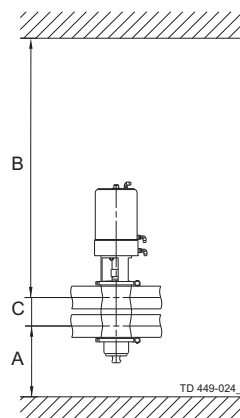

Table 1. (All measures in mm) (1 mm = 0.0394")

Size	ISO					DIN						
	DN/OD 38	DN/OD 51	DN/OD 63.5	DN/OD 76.1	DN/OD 101.6	DN 40	DN 50	DN 65	DN 80	DN 100	DN 125	DN 150
<b>A</b> Basic/SeatClean PMO	160	200	250	250	290	160	200	240	220	280	320	305
<b>A</b> HighClean/UltraClean PMO	200	265	300	300	360	200	265	290	270	350	390	375
<b>*C</b>	60.8	73.8	86.3	98.9	123.6	64	76	92	107	126	151	176
<b>B</b> Basic	700	760	909	909	1148	700	760	909	909	1148	1350	1370
SeatClean PMO	700	760	880	880	1050	700	760	880	880	1050	1250	1270
<b>B</b> HighClean/UltraClean PMO	810	870	1020	1020	1250	810	870	1020	1020	1250	1400	1420
		877	1047	1060	1250							

\* The measure C can always be calculated by the formula  $C = \frac{1}{2} \text{ID upper} + \frac{1}{2} \text{ID lower} + 26 \text{ mm (1")}$ .

Table 2. (All measures in mm) (1 mm = 0.0394")

Size	Sch. 5				
	Sch. 5 2"	Sch. 5 3"	Sch. 5 4"	Sch. 5 5"	Sch. 5 6"
<b>A</b> Basic/SeatClean	190	210	265	315	300
<b>A</b> HighClean/UltraClean	230	260	340	385	370
<b>*C</b>	83	110.7	136.1	161.8	188.8
<b>B</b> Basic	760	909	1148	1350	1370
SeatClean	760	880	1050	1250	1270
<b>B</b> HighClean/UltraClean	870	1020	1250	1420	1420

\* The measure C can always be calculated by the formula  $C = \frac{1}{2} \text{ID upper} + \frac{1}{2} \text{ID lower} + 26 \text{ mm (1")}$ .

### 3 Installation

Study the instructions carefully and pay special attention to the warnings!

The valve has ends for welding as standard.

**Weld carefully/aim at stressless welding to avoid deformation on sealing areas.**

**Check the valve for smooth operation after welding.**

**NOTE!**

If ThinkTop® is mounted, add 180 mm (7,1") to B measure.

**Table 3 and 4**

1. Lower sealing element can only be dismantled if actuator and internal parts are removed.

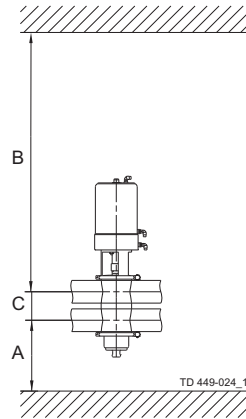

**Table 3.**

Size	ISO					DIN						
	DN/OD 38	DN/OD 51	DN/OD 63.5	DN/OD 76.1	DN/OD 101.6	DN 40	DN 50	DN 65	DN 80	DN 100	DN 125	DN 150
<b>A</b>												
Basic/Seat Clean	120	140	170	170	200	120	140	170	160	200	250	235
PMO		135	145	165	189							
<b>A</b>												
HighClean/UltraClean	170	190	220	220	270	170	190	220	210	270	320	305
PMO		190	220	240	259							

**Table 4.**

Size	Sch. 5				
	Sch. 5 2"	Sch. 5 3"	Sch. 5 4"	Sch. 5 5"	Sch. 5 6"
<b>A</b>					
Basic/Seat Clean	140	160	190	245	230
<b>A</b>					
HighClean/UltraClean	180	210	270	315	

*Study the instructions carefully and pay special attention to the warnings!*

*The valve has ends for welding as standard.*

*Weld carefully/aim at stressless welding to avoid deformation on sealing areas.*

*Check the valve for smooth operation after welding.*

---

### 3.4 Recycling information

---

- **Unpacking**

- Packing material consists of wood, plastics, cardboard boxes and in some cases metal straps
- Wood and cardboard boxes can be re-used, recycled or used for energy recovery
- Plastics should be recycled or burnt at a licensed waste incineration plant
- Metal straps should be sent for material recycling

- **Maintenance**

- During maintenance, oil and wearing parts in the machine are replaced
- All metal parts should be sent for material recycling
- Worn out or defective electronic parts should be sent to a licensed handler for material recycling
- Oil and all non-metal wear parts must be disposed off in agreement with local regulations

- **Scrapping**

- At end of use, the equipment must be recycled according to the relevant, local regulations. Besides the equipment itself, any hazardous residues from the process liquid must be considered and dealt with in a proper manner. When in doubt, or in the absence of local regulations, please contact your local Alfa Laval sales company
-

## 4 Operation

---

*The valve is adjusted and tested before delivery.  
Study the instructions carefully and pay special attention to the warnings!  
Pay attention to possible faults.  
The items refer to the parts list and service kits section.*

---

### 4.1 Operation

---

#### Step 1



**Always** read the technical data thoroughly.  
See section 6.1 Technical data



**Always** release compressed air after use.



**Never** touch the clip assembly or the actuator piston rod if the actuator is supplied with compressed air (see the warning label).



**Never** pressurise air connections (AC1, AC3) simultaneously as both valve plugs can be lifted (can cause mixing).

#### CAUTION

Alfa Laval cannot be held responsible for incorrect operation.

---

#### Step 2



**Never** touch the valve or the pipelines when processing hot liquids  
or when sterilising.

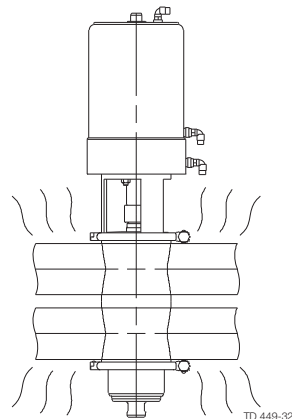

Burning danger!

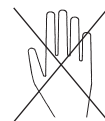



*The valve is adjusted and tested before delivery.  
Study the instructions carefully and pay special attention to the warnings!  
Pay attention to possible faults.  
The items refer to the parts list and service kits section.*

## 4.2 Fault finding and repair

### NOTE

Study the maintenance instructions carefully before replacing worn parts.

Problem	Cause/result	Repair
Leakage between sealing element (79) and lower plug (75)	Worn/product affected o-rings/ lip seal (76/77/78)	<ul style="list-style-type: none"> <li>- Replace the o-rings/lip seal</li> <li>- Change rubber grade</li> <li>- Lubricate correctly</li> </ul>
Leakage at the leakage outlet	<ul style="list-style-type: none"> <li>- Particles between valve seats and plug seals (56/74)</li> <li>- Worn/product affected plug seal rings (56/74)</li> <li>- Plug not assembled correctly</li> </ul>	<ul style="list-style-type: none"> <li>- Remove the particles</li> <li>- Check the plug seals</li> <li>- Replace the plug seals</li> <li>- Change rubber grade</li> <li>- Assemble plug, see step 3 section 5.5 Assembly of valve</li> </ul>
Leakage at sealing element (48)/upper plug (55)	Worn/product affected o-rings/lip seal (sizes 38/39/46/49)	<ul style="list-style-type: none"> <li>- Replace the o-rings/lip seal</li> <li>- Change rubber grade</li> <li>- Clean and if necessary replace guide ring (45)</li> </ul>
Leakage at clamp (64)	<ul style="list-style-type: none"> <li>- Too old/product affected o-rings (76 and 47) (and 52 if clamped valve body)</li> <li>- Loose clamp (64)</li> </ul>	<ul style="list-style-type: none"> <li>- Replace the o-rings</li> <li>- Change rubber grade</li> <li>- Tighten the clamp</li> </ul>
CIP leakage	Worn o-rings (40/67/71)	Replace the o-rings
Leakage at spindle clamp (43)	Damaged o-ring (39) W orn/product affected lip seal (57) or spray nozzle (58)	<ul style="list-style-type: none"> <li>- Replace the o-ring</li> <li>- Replace the plug seals</li> <li>- Change rubber grade</li> </ul>
Lower plug not returning to closed position	<ul style="list-style-type: none"> <li>- Wrong rubber grade</li> <li>- Wrongly fitted gasket</li> <li>- Mounted incorrectly (see section 2.3)</li> </ul>	<ul style="list-style-type: none"> <li>- Change rubber grade</li> <li>- Fit new gasket correctly</li> <li>- Correct installation</li> </ul>
Plug returns with uneven movements (slip/stick effect)	<ul style="list-style-type: none"> <li>- Wrong rubber grade</li> <li>- Wrongly fitted gasket</li> <li>- Mounted incorrectly (see section 2.3)</li> </ul>	<ul style="list-style-type: none"> <li>- Change rubber grade</li> <li>- Fit new gasket correctly</li> <li>- Correct installation</li> </ul>

## 4 Operation

The valve is designed for cleaning in place (CIP). CIP = Cleaning In Place.  
 Study the instructions carefully and pay special attention to the warnings!  
 NaOH = Caustic Soda. HNO<sub>3</sub> = Nitric acid.  
 Internal leakage in the valve is externally visible by means of the leakage outlet.

### 4.3 Recommended cleaning

#### Step 1



**Never** touch the valve or the pipelines when sterilising.

**Caustic danger!**



**Always** use rubber gloves!



**Always** use protective goggles!

#### Step 2



**Never** touch the valve or the pipelines when sterilising.

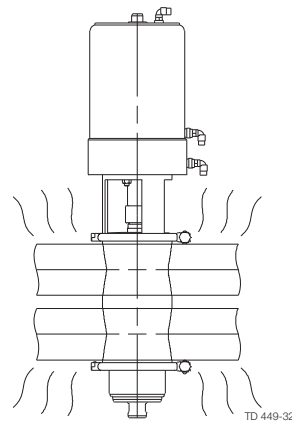

**Burning danger!**

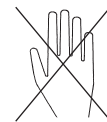

#### Step 3



**Never** throttle the leakage outlet.



**Never** throttle the CIP outlet, if supplied.  
 (Risk of mixing due to overpressure).

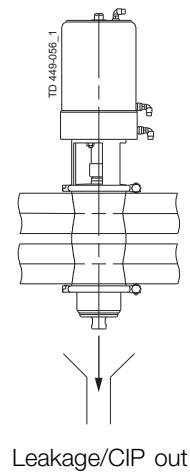

CIP in CIP in

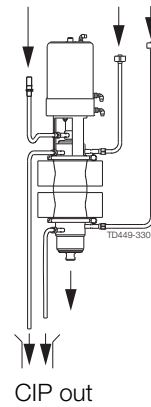

#### Step 4

##### Examples of cleaning agents:

Use clean water, free from chlorides.

1. 1% by weight NaOH at 70° C (158° F) .

1 kg (2.2 lb) NaOH	+	100 l (26.4 gal) water	=	Cleaning agent.
-----------------------	---	---------------------------	---	-----------------

2. 0.5% by weight HNO<sub>3</sub> at 70° C (158° F).

0.7 l (0.2 gal) 53% HNO <sub>3</sub>	+	100 l (26.4 gal) water	=	Cleaning agent.
---	---	---------------------------	---	-----------------

2.2 l (0.6 gal) 33%NaOH	+	100 l (26.4 gal) water	=	Cleaning agent.
----------------------------	---	---------------------------	---	-----------------

The valve is designed for cleaning in place (CIP). CIP = Cleaning In Place.  
Study the instructions carefully and pay special attention to the warnings!  
NaOH = Caustic Soda. HNO<sub>3</sub> = Nitric acid.  
Internal leakage in the valve is externally visible by means of the leakage outlet.

### Step 5

1. Avoid excessive concentration of the cleaning agent  
=> **Dose gradually!**
2. Adjust the cleaning flow to the process.  
**Milk sterilization/viscous liquids**  
=> **Increase the cleaning flow!**

### Step 6

Advisory seat lift cleaning periods:  
Cleaning periods of 3-6 seconds per CIP sequence.

Product	Periods
Milk	1-2
Yoghurt	3-5
Beer	2-5
Cold wort	5-10

### Step 7

**Always** rinse well with clean water after the cleaning.

#### NOTE

The cleaning agents must be stored/disposed of in accordance with current regulations/directives.

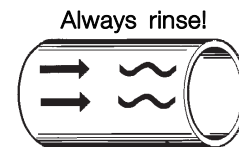

Clean water    Cleaning agents

## 4 Operation

The valve is designed for cleaning in place (CIP). CIP = Cleaning In Place.  
Study the instructions carefully and pay special attention to the warnings!  
NaOH = Caustic Soda. HNO<sub>3</sub> = Nitric acid.  
Internal leakage in the valve is externally visible by means of the leakage outlet.

**Seat-cleaning cycles:**  
Pay special attention to the warnings!  
1. Closed valve

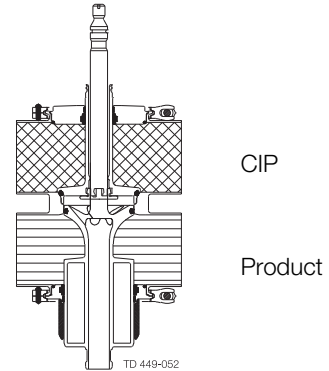

2. Cleaning through lower line

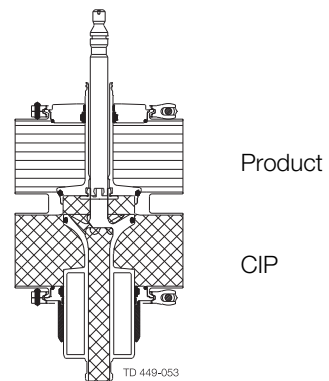

3. Open valve

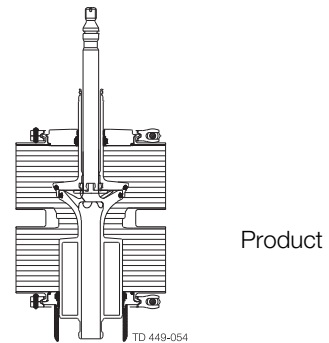

4. Cleaning through upper line

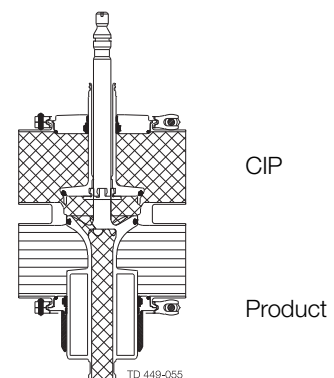

Maintain the valve/actuator regularly. Study the instructions carefully and pay special attention to the warnings!  
Always keep spare rubber seals and guide rings in stock. The items refer to the parts list and service kits section.  
The valve is designed so that internal leakages do not result in the products becoming mixed.  
Internal leakage in the valve is externally visible. Check the valve for smooth operation after service.

5.1 General maintenance

Step 1



Always read the technical data thoroughly.  
See section 6.1 Technical data



Always fit the seals correctly (risk of mixing).



Always release compressed air after use.



Always remove the CIP connections, if supplied, before service.

NOTE

All scrap must be stored/discharged in accordance with current rules/directives.

Step 2



Never service the valve when it is hot.



Never service the valve with valve/actuator under pressure.

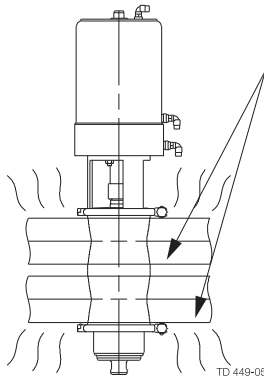

Atmospheric pressure required!

Burning danger!

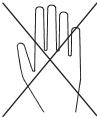

Step 3



Never stick your fingers through the valve ports if the actuator is supplied with compressed air.

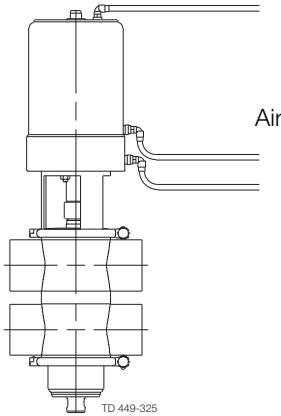

Cutting danger!



## 5 Maintenance

Maintain the valve/actuator regularly. Study the instructions carefully and pay special attention to the warnings! Always keep spare rubber seals and guide rings in stock. The items refer to the parts list and service kits section. The valve is designed so that internal leakages do not result in the products becoming mixed. Internal leakage in the valve is externally visible. Check the valve for smooth operation after service.

### Step 4



**Never** touch the clip assembly or the actuator piston rod if the actuator is supplied with compressed air (see the warning label).

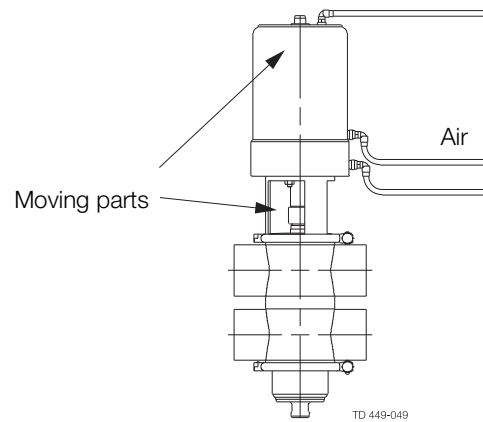

### Recommended spare parts: Service kits

Order service kits from the service kits section - see section 7 Parts list and service kits

**Ordering spare parts:** Contact the Sales Department.

	Valve rubber seals	Valve plug seals	Valve guide rings
Preventive maintenance	<b>Replace after 12 months(*)</b>	<b>Replace after 12 months(*)</b>	Replace when required
Maintenance after leakage (leakage normally starts slowly)	<b>Replace after production cycle</b>	<b>Replace after production cycle</b>	
Planned maintenance	<ul style="list-style-type: none"> <li>- Regular inspection for leakage and smooth operation</li> <li>- Keep a record of the valve</li> <li>- Use the statistics for planning of inspections</li> </ul>	<ul style="list-style-type: none"> <li>- Regular inspection for leakage and smooth operation</li> <li>- Keep a record of the valve</li> <li>- Use the statistics for planning of inspections</li> </ul>	Replace when required
Lubrication	<b>When assembling</b> Klüber Paraliq GTE 703 or similar USDA H1 approved oil/grease (**) (suitable for EPDM)	<b>When assembling</b> Klüber Paraliq GTE 703 or similar USDA H1 approved oil/grease (**) (suitable for EPDM)	<b>None</b>

### NOTE!

Lubricate thread in valve plug parts with Klüber Paste UH1 84-201 or similar.

(\*) Depending on working conditions! Please contact Alfa Laval.

(\*\*) All products wetted seals.

Study the instructions carefully.

The items refer to the parts list and service kits section.

Handle scrap correctly.

Replace seals if necessary.

### Repairing of actuator:

- The actuator is maintenance-free but repairable.
- If repair is required, replacing all actuator rubber seals is recommended.
- Lubricate seals with Klüberplex BE31.
- To avoid possible black remains on pos. 1 and 29, Alfa Laval recommends Klüber Paraliq GTE703 (white) for these two positions.

### Pre-use check

1. Supply compressed air to AC1, AC2 and AC3 one by one.
2. Operate the valve several times to ensure that it operates smoothly.

**Pay special attention to the warnings!**

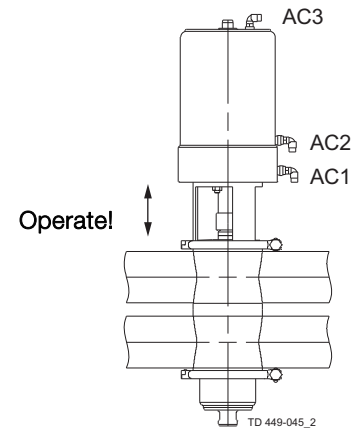

## 5.2 Dismantling the valve

### Step 1

Disassemble valve acc. to illustrations ( 1 to 6 ).

1. Supply compressed air to AC2.
2. Loosen and remove upper clamp (64).
3. Release compressed air.
4. Lift out the actuator together with the internal valve parts from valve body (50).
5. Loosen and remove lower clamp (64).
6. Take away lower sealing element (79).

### OPTION:

If clamped valve body: Loosen and remove clamp and pull upper (51) and lower (53) valve bodies apart. Pull out o-ring (52).

### NOTE

Release compressed air.

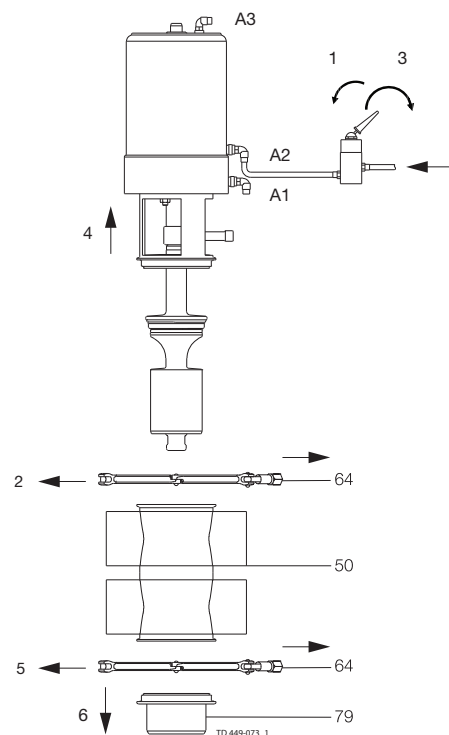

## 5 Maintenance

Study the instructions carefully.

The items refer to the parts list and service kits section.

Handle scrap correctly.

Replace seals if necessary.

### Step 2

Dismantling of lower sealing element:

1. Pull out o-ring (76) and lip seal (77).
2. Remove o-ring (78).
3. Screw out flushing tubes (70).
4. Remove o-rings (71) and nozzles (72 + 73).

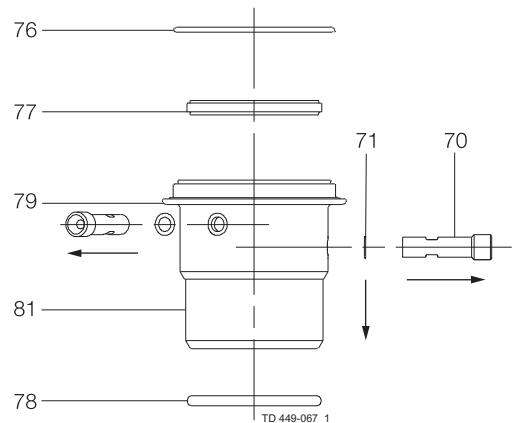

### Step 3

3A:

If air fitting AC1 is present, supply compressed air and follow procedure 3A.

1. Supply compressed air for AC1.
2. Loosen lower plug (75) while counterholding upper stem (1).
3. Remove the plug.
4. Release compressed air.

A. On

B. Off

If upper seat lift available

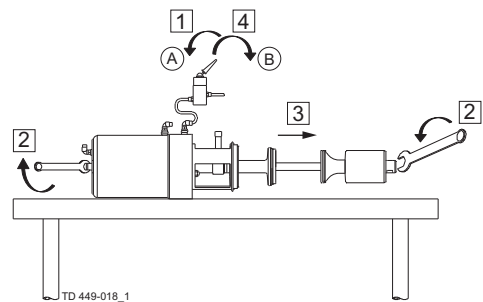

3B:

If no air fitting AC1 is present, follow procedure 3B.

1. Push upper sealing element (48) free of intermediate piece (37).
2. Loosen lower plug while counterholding upper stem.
3. Remove the plug (75).

Replace o-ring (38).

**Note:** For replacement of seal ring (74), please see section 5.3 Lower plug, replacement of radial seal.

If no upper seat lift available

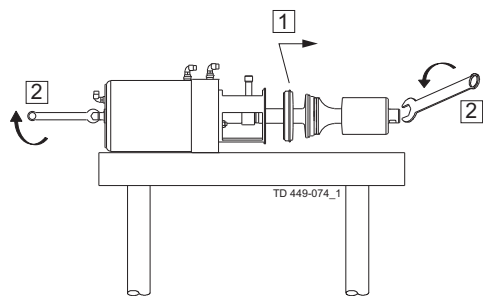

### Step 4

Remove coupling system and upper plug according to illustrations (1 to 4).

1. Unscrew flushing tube (41) (or plug (15) if no CIP). Remove o-ring (40).
2. Pull up lock (44) over piston rod (29).
3. Pull away clamps (43) from spindle liner (42).
4. Pull out upper plug (55). Make sure spindle liner is free of both piston rod and upper plug. If external CIP to leakage chamber: Remove o-rings (39).

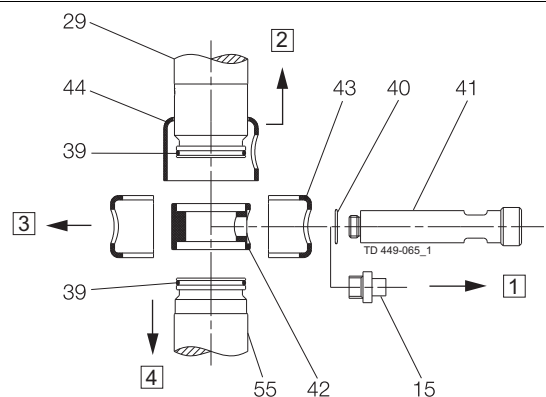



Study the instructions carefully.

The items refer to the parts list and service kits section.

Handle scrap correctly.

### Step 5

1. If present, unscrew flushing tubes (66) and remove o-rings (67) and nozzles (68 + 69).
2. Pull out upper sealing element (48) from intermediate piece (37).
3. Pull out o-ring (47), lip seal (49) and o-ring (46) from upper sealing element.

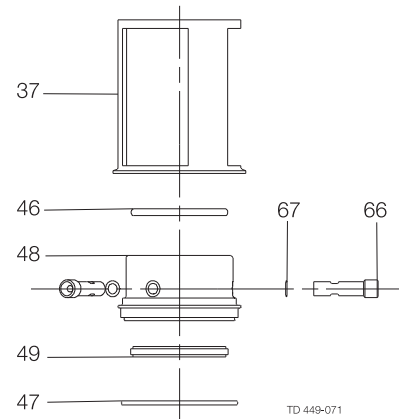

### Step 6

Remove lip seal (57) (or spray nozzle (58) if valve is supplied with Spiral-Clean). For removal and replacement of seal ring (56), please see section 5.3 Lower plug, replacement of radial seal.

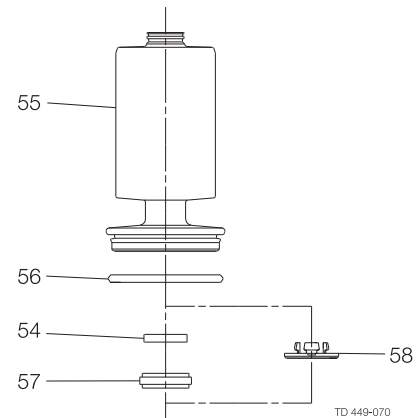

## 5.3 Lower plug, replacement of radial seal

### Step 1

Cut and remove old seal ring (74) using a knife, screwdriver or similar. Be careful not to scratch the plug.

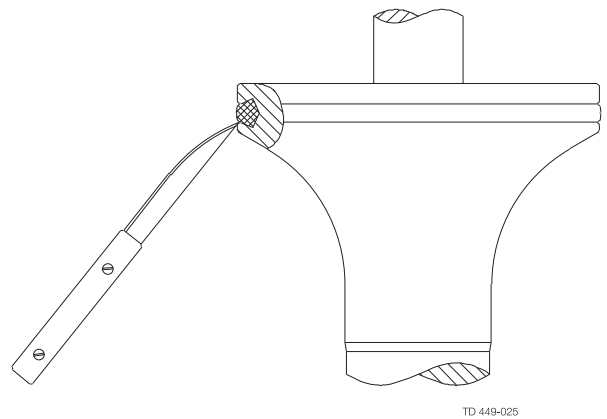

## 5 Maintenance

Study the instructions carefully.

The items refer to the parts list and service kits section.

Handle scrap correctly.

### Step 2

Pre-mount seal ring as shown on drawing.

Rotate along circumference to fix gasket as shown in the picture.

Carefully lubricate sealings with acceptable soap or lubricant, before pre-mounting.

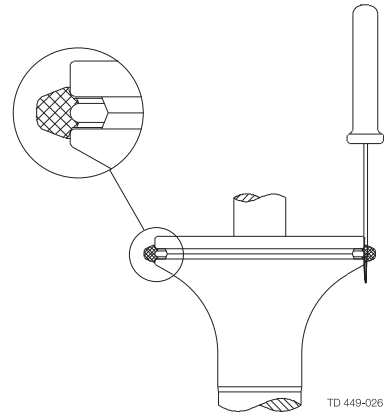

### Step 3

Place lower tool part.

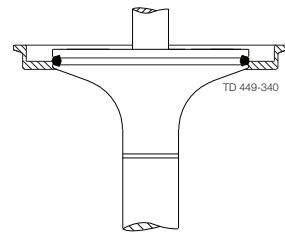

Item no.				Tool for radial sealing, lower plug
Seat ø53	Seat ø81	Seat ø110	Seat ø115	
9613-4260-01	9613-4260-02	9613-4260-03	9613-4260-04	

### Step 4

1. Place upper tool part including piston.

2. Clamp the two tool parts together.

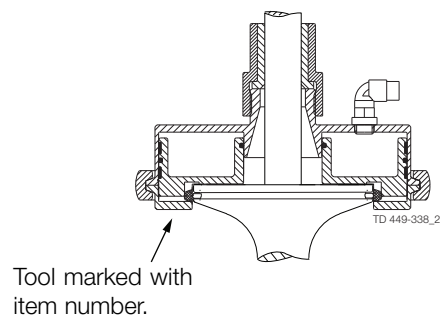

Study the instructions carefully.  
The items refer to the parts list and service kits section.  
Handle scrap correctly

### Step 5

1. Supply compressed air.
2. Release compressed air.
3. Remove tool parts.

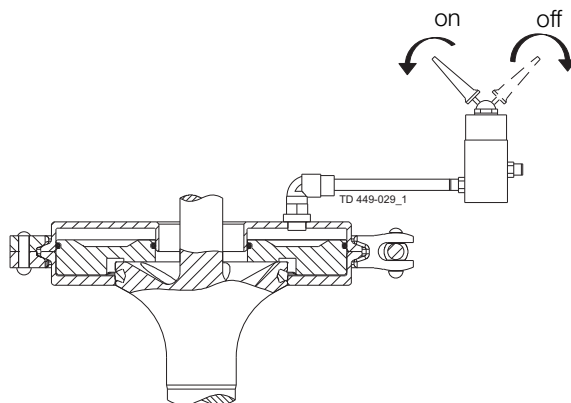

### Step 6

Inspect the seal to ensure it does not twist in the groove, and press in the 4 outsticking points with a screwdriver!

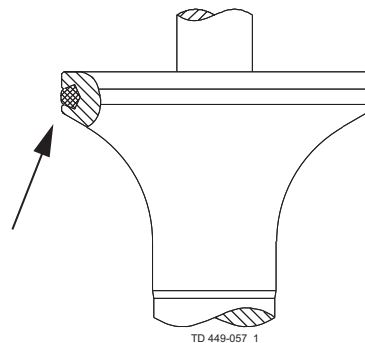

## 5.4 Upper plug, replacement of axial seal

### Step 1

Remove old seal ring (56) using a knife, screwdriver or similar.  
Be careful not to scratch the plug.

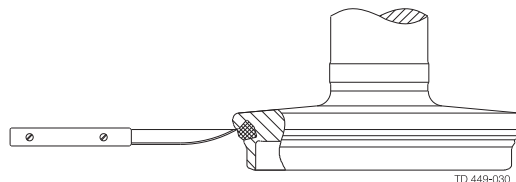

### Step 2

Pre-mount seal ring as shown on drawing.

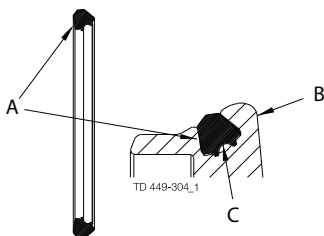

- A = Flat side of sealing
- B = Balanced plug
- C = Do not lubricate behind the sealing

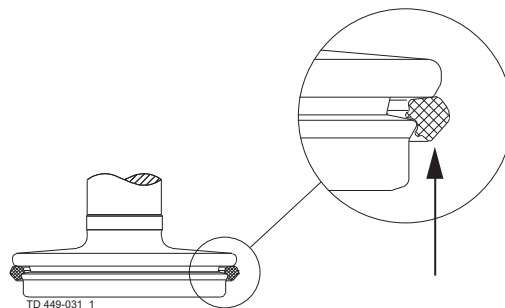

Carefully lubricate sealings with acceptable soap or lubricant, before pre-mounting.

## 5 Maintenance

Study the instructions carefully.

The items refer to the parts list and service kits section.

Handle scrap correctly

### Step 3

Place tool part 1.

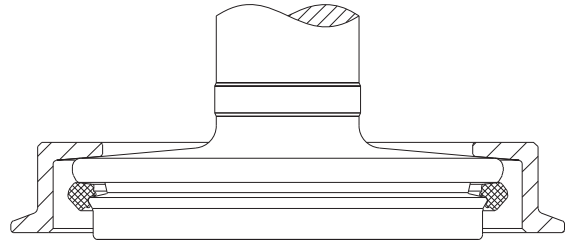

TD 449-032

Item no.				Tool for axial sealing, upper plug
Seat ø53	Seat ø81	Seat ø110	Seat ø115	
9613-0505-01	9613-0505-02	9613-0505-08	9613-0505-03	

TD 449-033

### Step 4

1. Place tool part 2 including piston.
2. Clamp the two tool parts together.

Tooling marked with item number

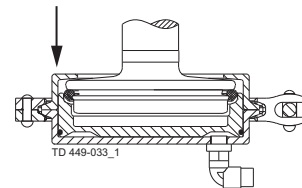

TD 449-033\_1

### Step 5

1. Supply compressed air.
2. Release compressed air.
3. Rotate the tool 45° with regards to the plug.
4. Supply compressed air.
5. Release compressed air and remove tool.

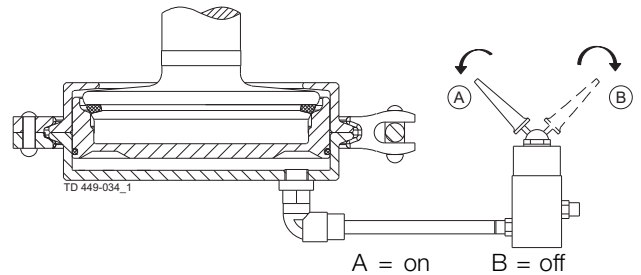

TD 449-034\_1

A = on B = off

### Step 6

1. Inspect the seal.
2. Release air at 3 different positions of the circumference.

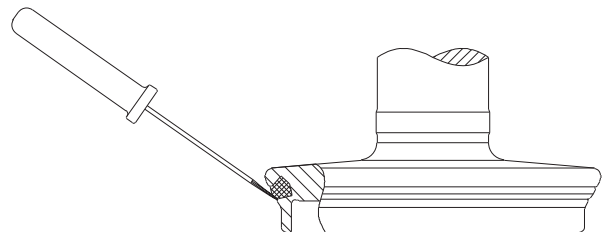

TD 449-042

Study the instructions carefully.  
 The items refer to the parts list and service kits section.  
 Handle scrap correctly.  
 Replace seals if necessary.

## 5.5 Assembly of valve

### Step 1

1. Fit o-ring (47) (do not twist), lip seal (49) and o-ring (46) in upper sealing element (48) (Lubricate with Klüber Paralique GT 703).
- NOTE:** The o-ring should be gently pressed into the groove
2. Fit upper sealing element in intermediate piece (37).
  3. Place o-rings (67) and mount flushing tubes (66). Be sure to align nozzles (68 + 69) towards recess.

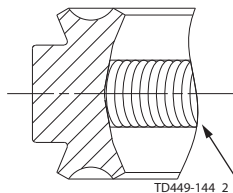

Lubricate with Klüber Paralique GT 703

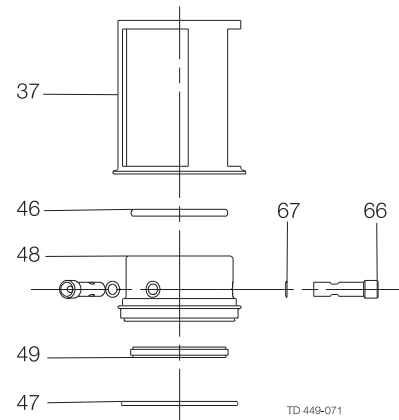

### Step 2

1. Place lip seal (57) in upper plug (or spray nozzle if the valve has SpiralClean) and the o-ring (38) in the lower plug.
  2. Press lower plug (75) rapidly into upper plug (55) through the lip seal.
- Note:** Do not damage the lips when lower plug (75) with o-ring (38) passes the lip seal.

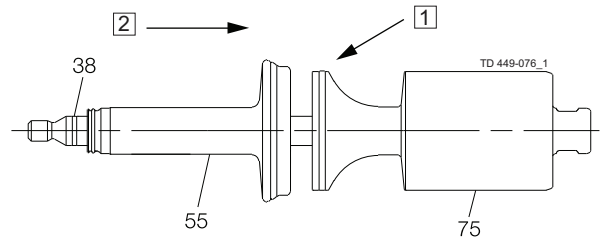

### Step 3

Place coupling system and upper plug according to illustrations ( 1 to 4 ).

1. Push lock (44) up over piston rod (29).
2. If external CIP to leakage chamber: Place o-rings (39).
3. Place spindle liner (42) on piston rod. Fit upper plug (55).
4. Mount clamps (43) on spindle liner (42).
5. Fit lock (44).
6. Fit o-ring (40). Fit flushing tube (41) (or plug (15) if no CIP).

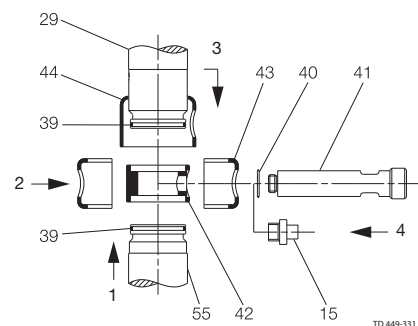

## 5 Maintenance

Study the instructions carefully.

The items refer to the parts list and service kits section.

Handle scrap correctly.

Replace seals if necessary.

### Step 4

Recommended torque values for fitting upper and lower plug parts

Dimension	Torque (Nm)/(lbf-ft)
38 mm/DN 40	
51 mm/DN 50	5/(3.7)
Sch. 5 2"	
All others	20/(14.8)

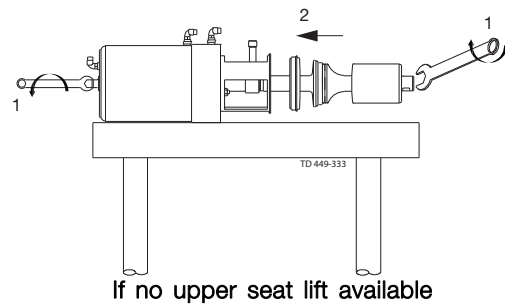
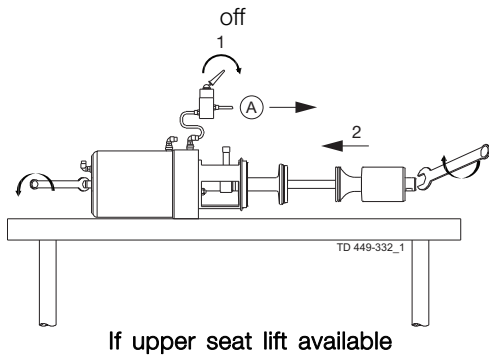

A = air

### Step 5

1. Place o-rings (71) and fit nozzles (72 + 73) and flushing tubes (70), if present.
2. Place o-ring (78) and fit lip seal (77) and o-ring (76) (do not twist the o-ring) and press it gently into the groove (lubricate with Klüber Paralique GT703)

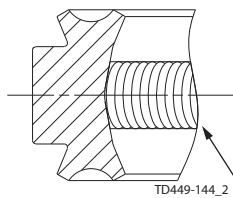

Lubricate with Klüber Paralique GT 703

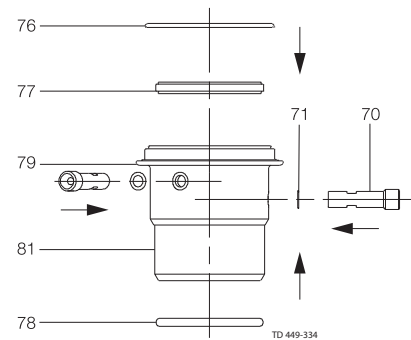

Study the instructions carefully.  
The items refer to the parts list and service kits section.  
Handle scrap correctly.  
Replace seals if necessary.

**Step 6**

- **Never** stick your fingers through the valve ports if the actuator is supplied with compressed air.
  - **Always** supply compressed air, before demounting the valve.
- If clamped valve body: First place o-ring (52) and fit upper (51) and lower (53) valve bodies. Fit and tighten clamp (64).

Reassemble valve according to illustrations ( 1 - 6 ).

1. Fit lower sealing element (79).
2. Fit and tighten lower clamp (64).
3. Supply compressed air and mount the actuator together with the internal valve parts from valve body (50).
4. Fit and tighten upper clamp (64). Greasing of clamp and clamp nut recommended!  
**(Maximum torque for clamp nut: 10Nm/7.4 lbf-ft)**
5. Release compressed air.

**NOTE**

Supply compressed air before demounting the valve.

- A = on
- B = off
- C = air

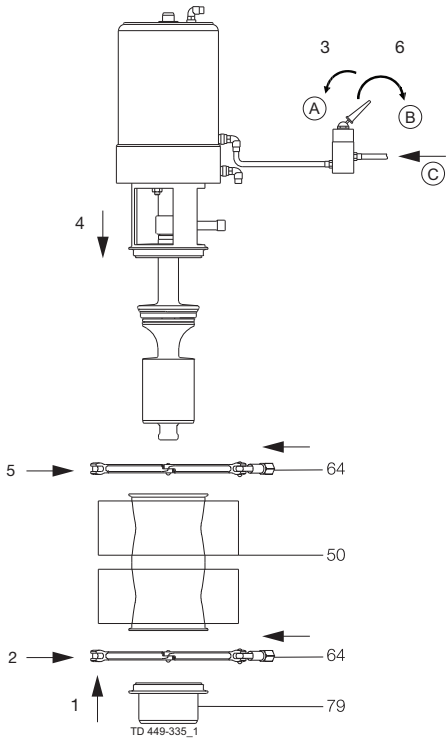

## 5 Maintenance

Study the instructions carefully.

The items refer to the parts list and service kits section.

Handle scrap correctly.

Replace seals if necessary.

### 5.6 Dismantling of actuator

#### Step 1

1. Dismantle the valve in accordance with instructions in section 5.2 Dismantling the valve  
**Pay special attention to the warnings!**
2. The actuator is now ready for service.  
Please see drawing when dismantling according to steps 2 to 6 on this page.

**Note!** The actuator is maintenance free but repairable.

#### Step 2

1. Remove nuts (36) and washers (35).
2. Pull out intermediate piece (37) from the actuator.
3. Remove cover disk (25).
4. Remove retaining ring (24).

#### Step 3

1. Remove piston rod (29), bottom (21) and lower piston (30). Separate the three parts.
2. Remove o-rings (20, 22 and 23) from bottom, o-rings (33 and 31) and guide ring (32) from lower piston as well as o-ring (28) from piston rod.
3. Remove spring assembly (14).

#### Step 4

1. Remove inner stem (27), main piston (17) and distance spacer (11) if present. Remove guide ring (18) and o-ring (19).
2. Remove spring assembly (10).

#### Step 5

**Note!** Not on actuator 3.

1. Unscrew screws (2) (are glued!).
2. Remove stop (4).
3. Remove upper piston (8). Remove o-rings (7 and 9).

#### Step 6

Remove o-ring (5) and guide ring (6).

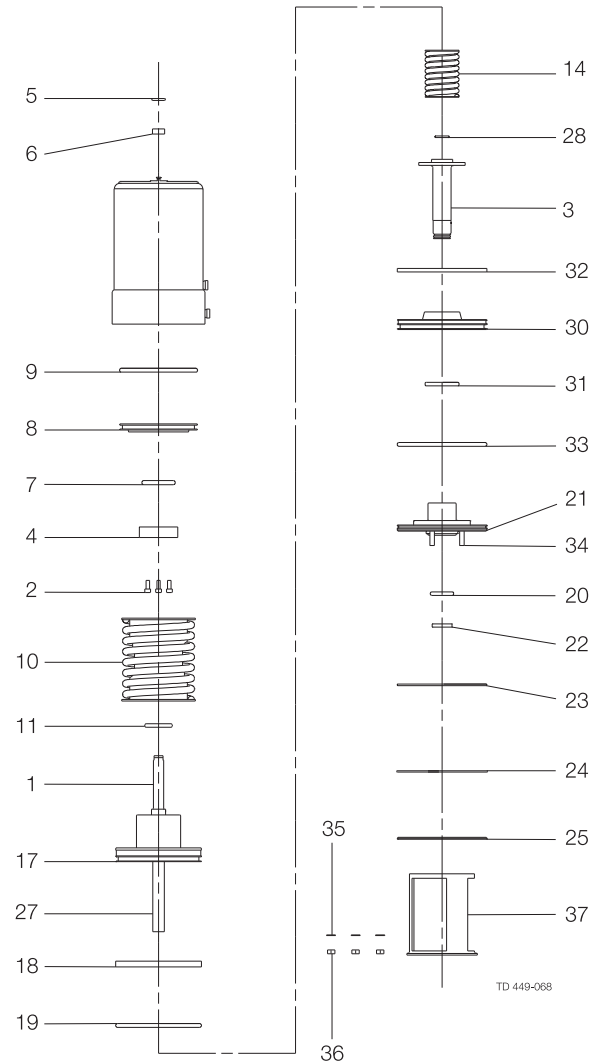



Study the instructions carefully.  
 The items refer to the parts list and service kits section.  
 Replace seals if necessary.  
 Lubricate the rubber seals before fitting them.

5.7 Assembly of actuator

**Step 1**  
 Please see drawing when reassembling according to steps 2 to 5 on this page.

**Note!** The actuator is maintenance free but repairable.

**Step 2**

1. Fit guide ring (6) and o-ring (5).
- Note!** Not on actuator 3:
2. Fit o-rings (7 and 9). Place upper piston (8).
3. Fit stop (4).
4. Tighten screws (2). (Secure with glue)

**Step 3**

1. Place spring assembly (10).
2. Fit o-ring (19) and guide ring (18). Mount distance spacer (11), main piston (17) and inner stem (27).

**Step 4**

1. Fit spring assembly (14).
2. Fit o-ring (28) in piston rod, fit o-rings (33 and 31) and guide ring (32) in lower piston and fit o-rings (20, 22 and 23) in bottom.
3. Fit piston rod (29), lower piston (30) and bottom (21).
4. Mount the three parts.

**Step 5**

1. Fit retaining ring (24).
2. Fit cover disk (25).
3. Mount intermediate piece (37) on actuator.
4. Fit and tighten nuts (36) and washers (35).

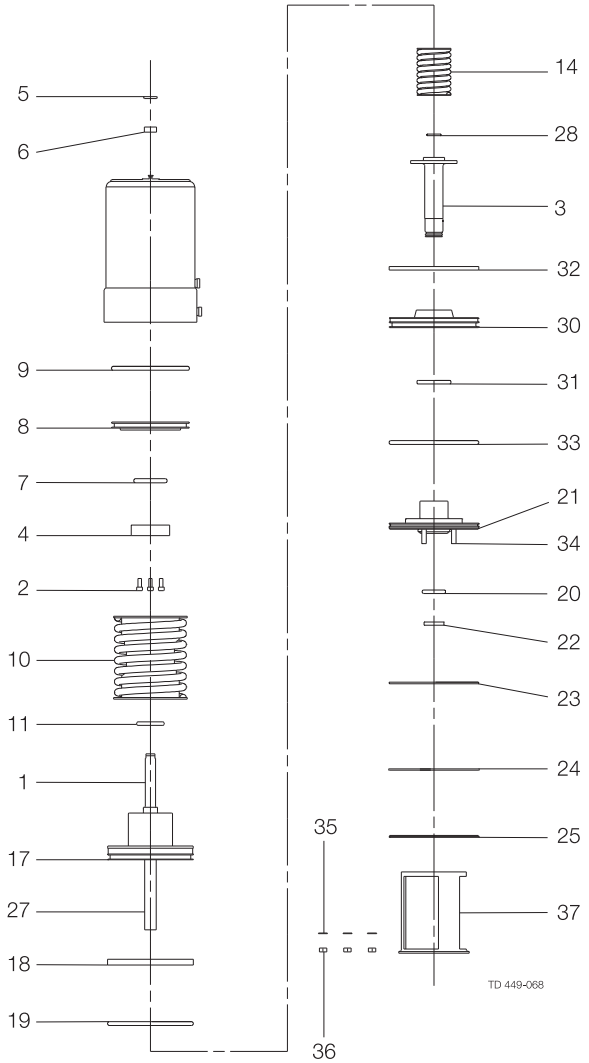

## 6 Technical data

*It is important to observe the technical data during installation, operation and maintenance.  
Inform the personnel about the technical data.*

### 6.1 Technical data

Unique is remote-controlled by means of compressed air. The valve is a normally closed (NC) valve.

The valve has two independent plug seals, forming a leakage chamber between them under atmospheric pressure during every working condition. In case of rare accidental leaking of product, this will flow into the leakage chamber and be discharged through the leakage outlet.

Data	
Max. product pressure:	1000 kPa (10 bar) (145 psi)
Min. product pressure:	Full vacuum
Recommended min. pressure for SpiralClean:	2 bar (29 psi)
Temperature range:	-5°C to +125°C (23°F - 257°F) (Depending on rubber quality)
Air pressure:	Max. 800 kPa (8 bar) (116 psi)
Products acc. to PED 97/23/EC	Category I, Fluids group 1 DN ≥ 125 Fluids group 2
Materials	
Product wetted steel parts:	Acid-resistant steel AISI 316L
Other steel parts:	Stainless steel AISI 304
Product wetted parts:	EPDM, HNBR, NBR or FPM
Other seals:	CIP seals: EPDM
Actuator seals:	NBR
Surface finish:	Internal/external matt (blasted) Ra < 1.6 (64 μ") Internal bright (polished) Ra < 0.8 (32 μ") Internal/external bright (internal polished) Ra < 0.8 (32 μ")

**Note!** The Ra-values are only for the internal surface.

#### Weight (kg)

Size	DN/OD					DN						
	38	51	63.5	76.1	101.6	40	50	65	80	100	125	150
Weight (kg) - Basic	13.5	15	24	24	34	13.5	15	24	24	34	44	45
Weight (kg) - SeatClean	13.5	15	24	24	34	13.5	15	24	24	34	47	48
Weight (kg) - High-/UltraClean	14.5	16	27	27	38	14.5	16	27	27	38	51	52

#### Noise

One metre away from - and 1.6 metre above the exhaust the noise level of a valve actuator will be approximately 77db(A) without noise damper and approximately 72 db(A) with damper - measured at 7 bars air-pressure.

## 6 Technical data

*It is important to observe the technical data during installation, operation and maintenance.  
Inform the personnel about the technical data.*

Below table values for the Unique PMO version please refer to PD sheet PD66352.

Size ISO/DIN/Sch.5	DN/OD					DN							Sch. 5				
	38	51	63.5	76.1	101.6	40	50	65	80	100	125	150	2"	3"	4"	5"	6"
Kv-value																	
Upper Seat-lift [m <sup>3</sup> /h]	1.5	1.5	2.5	2.5	3.1	1.5	1.5	2.5	2.5	3.1	3.7	3.7	1.5	2.5	3.1	3.7	3.7
Kv-value																	
Lower Seat-lift [m <sup>3</sup> /h]	0.9	0.9	1.9	1.9	2.5	0.9	0.9	1.9	1.9	2.5	3.1	3.1	0.9	1.9	2.5	3.1	3.1
Air consumption																	
Upper Seat-lift *[n litre]	0.2	0.2	0.4	0.4	0.62	0.2	0.2	0.4	0.4	0.62	0.62	0.62	0.2	0.4	0.62	0.62	0.62
Air consumption																	
Lower Seat-lift *[n litre]	1.1	1.1	0.13	0.13	0.21	1.1	1.1	0.13	0.13	0.21	0.21	0.21	1.1	0.13	0.21	0.21	0.21
Air consumption																	
Main Movement *[n litre]	0.86	0.86	1.63	1.63	2.79	0.86	0.86	1.62	1.62	2.79	2.79	2.79	0.86	1.63	2.79	2.79	2.79
Kv-value SpiralClean																	
Spindle CIP [m <sup>3</sup> /h]	0.12	0.12	0.12	0.12	0.12	0.12	0.12	0.12	0.12	0.12	0.12	0.12	0.12	0.12	0.12	0.12	0.12
Kv-value SpiralClean																	
External CIP of leakage chamber [m <sup>3</sup> /h]	0.25	0.25	0.29	0.29	0.29	0.25	0.25	0.29	0.29	0.29	0.29	0.29	0.25	0.29	0.29	0.29	0.29

### Note:

\* [n litre] = volume at atmospheric pressure.

**Formula to estimate CIP flow during seat lift** (for liquids with comparable viscosity and density to water):

$$Q = K_v \cdot \sqrt{\Delta p}$$

Q = CIP - flow (m<sup>3</sup>/h).

Kv = Kv value from the above table.

$\Delta p$  = CIP pressure (bar).

$$C_v = 1.163 \times K_v \text{ gpm}$$

1 bar = 14.5 psi

## 7 Parts list and service kits

*It is important to observe the technical data during installation, operation and maintenance.  
Inform the personnel about the technical data.*

### 7.1 Four configurations examples

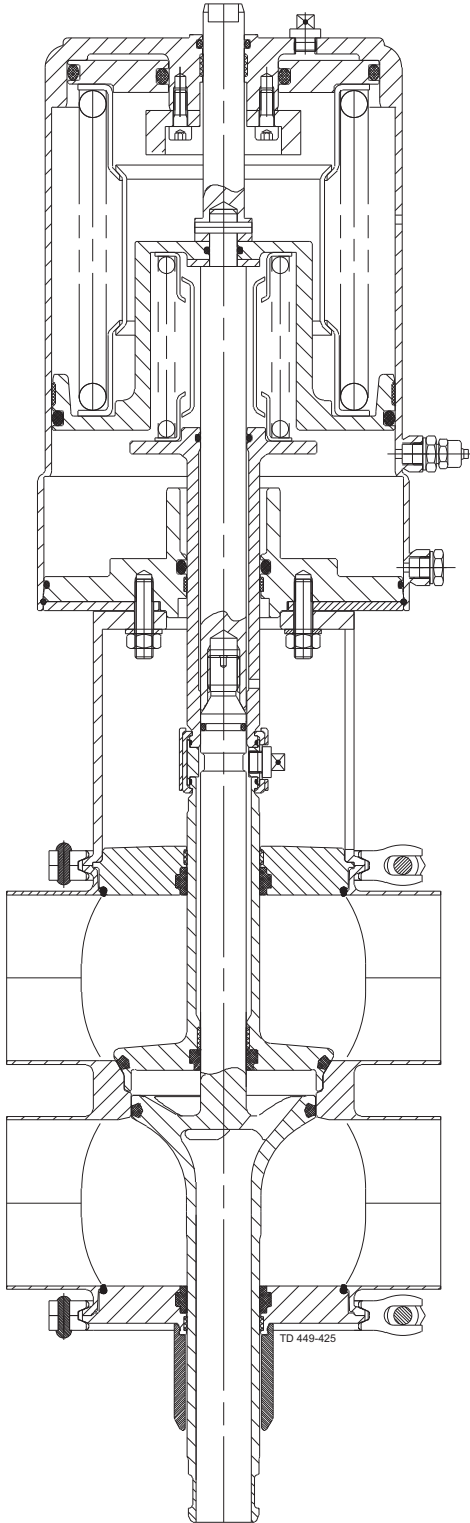

Basic

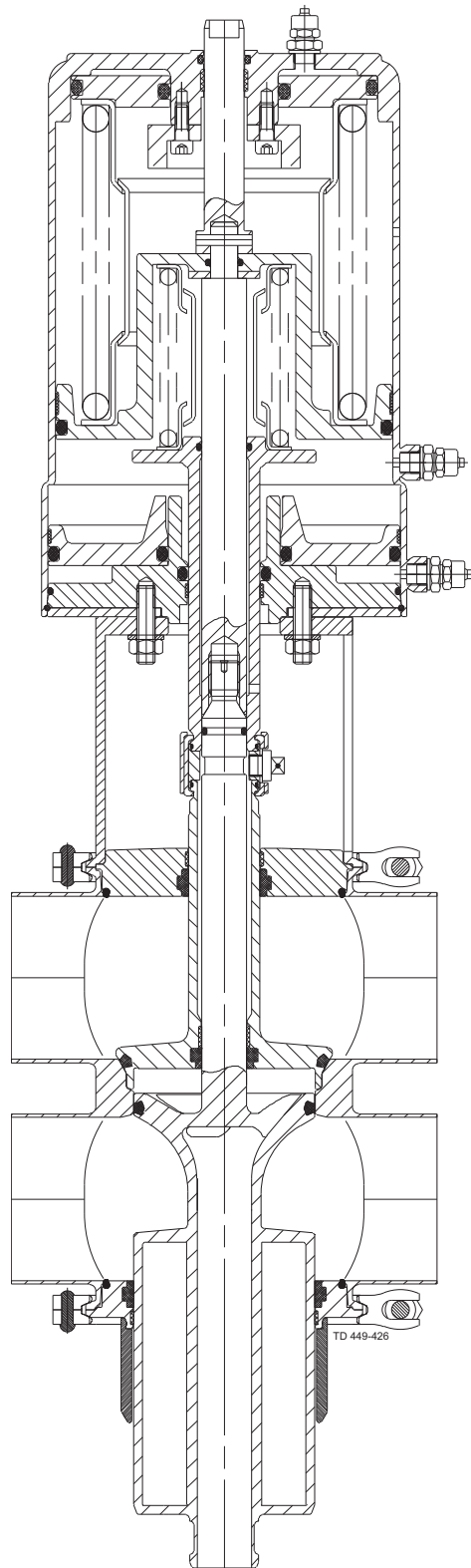

SeatClean

## 7 Parts list and service kits

*It is important to observe the technical data during installation, operation and maintenance.  
Inform the personnel about the technical data.*

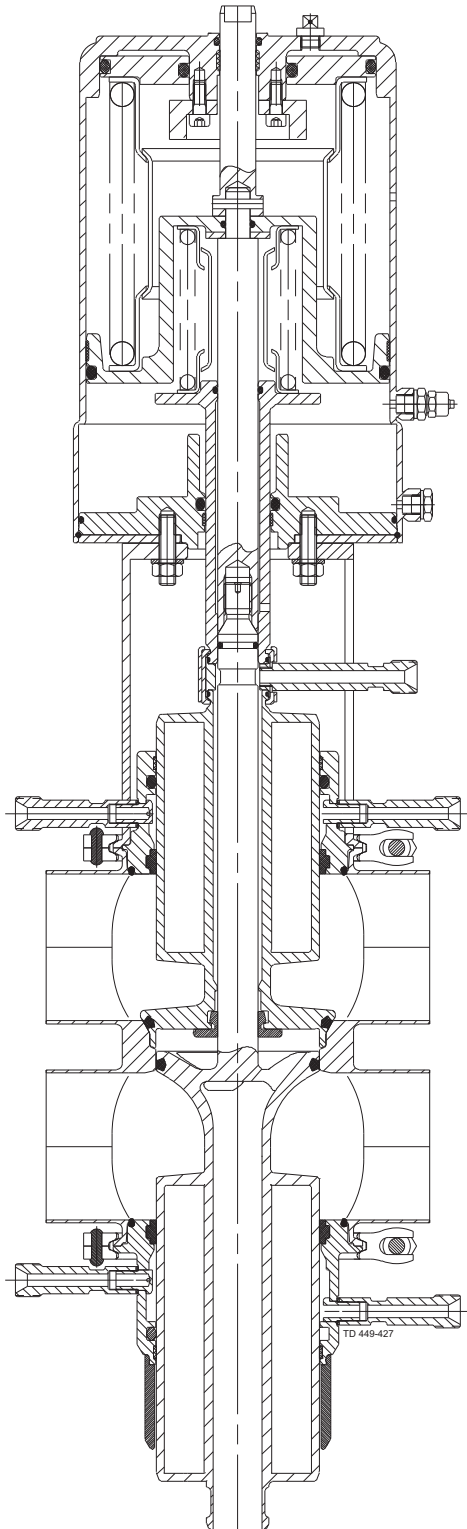

HighClean

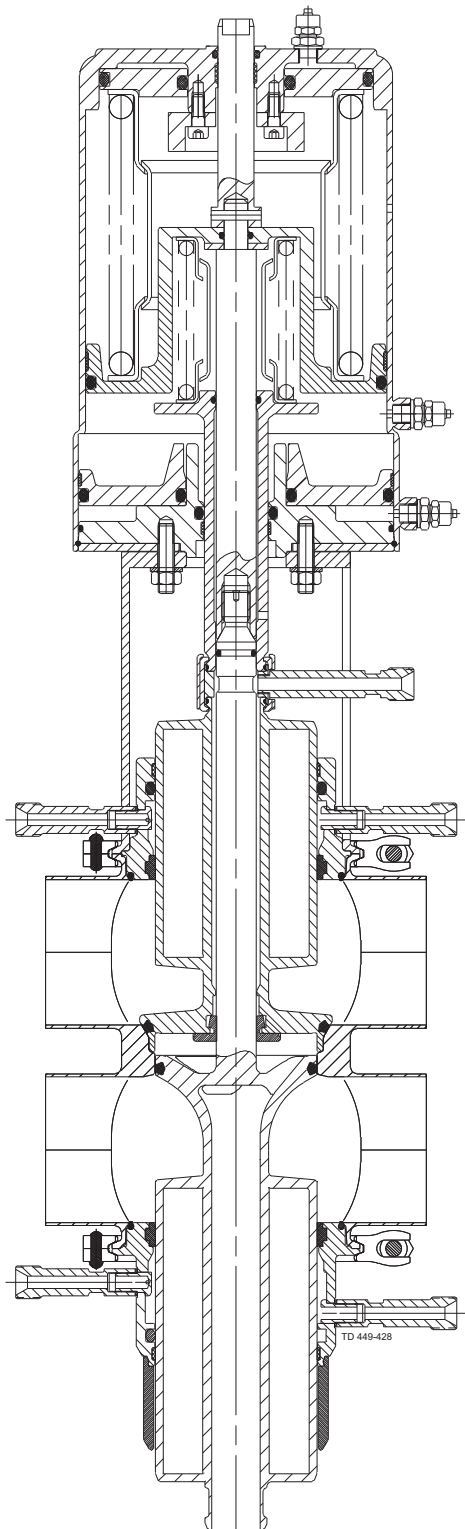

UltraClean

## 7 Parts list and service kits

*It is important to observe the technical data during installation, operation and maintenance.  
Inform the personnel about the technical data.*

### 7.2 Wear parts

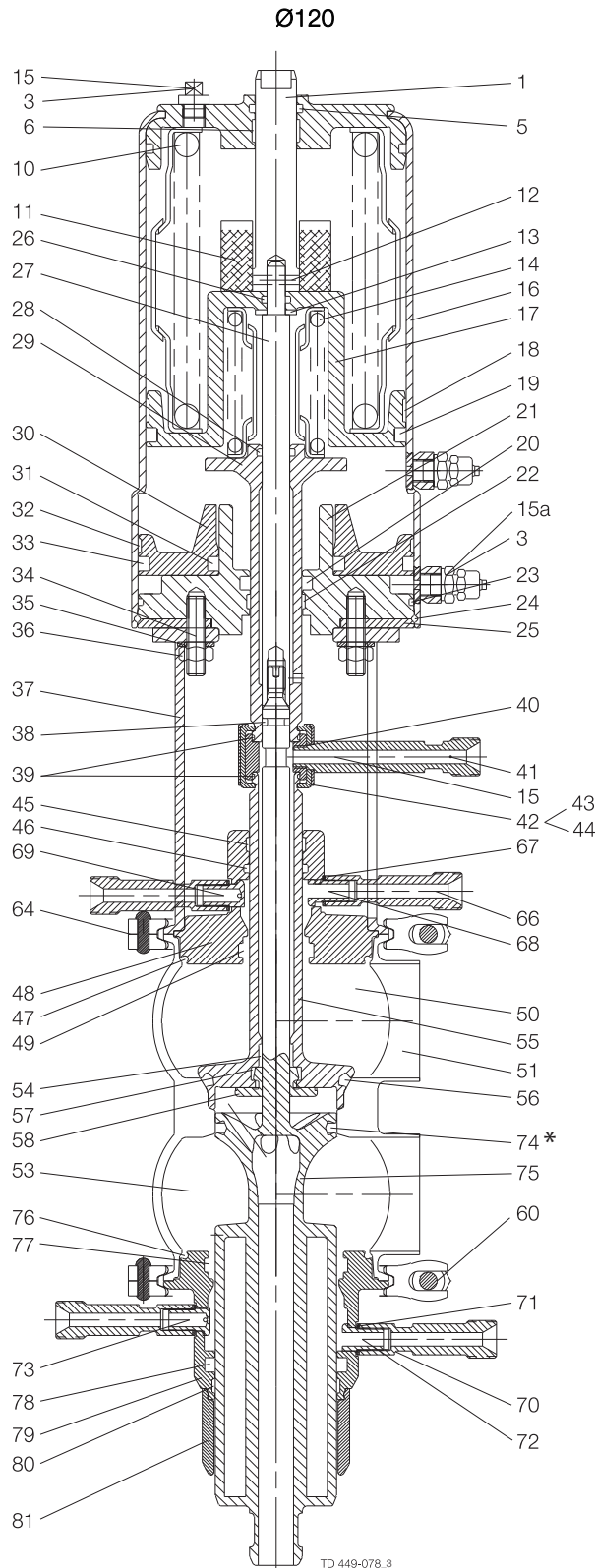

\* = All FPM service kits are supplied with EPDM seal ring (pos. 74)

## 7 Parts list and service kits

---

*It is important to observe the technical data during installation, operation and maintenance.  
Inform the personnel about the technical data.*

---

### Parts list

Pos.	Qty	Denomination
38	1	O-ring
39	2	O-ring
40	1	O-ring
46	1	O-ring
47	1	O-ring
49	1	Lip seal
52	1	O-ring
56	1	Seal ring
57	1	Lip seal
67	2	O-ring
71	2	O-ring
74	1	Seal ring
76	1	O-ring
77	1	Lip seal
78	1	O-ring

## 7 Parts list and service kits

*It is important to observe the technical data during installation, operation and maintenance.  
Inform the personnel about the technical data.*

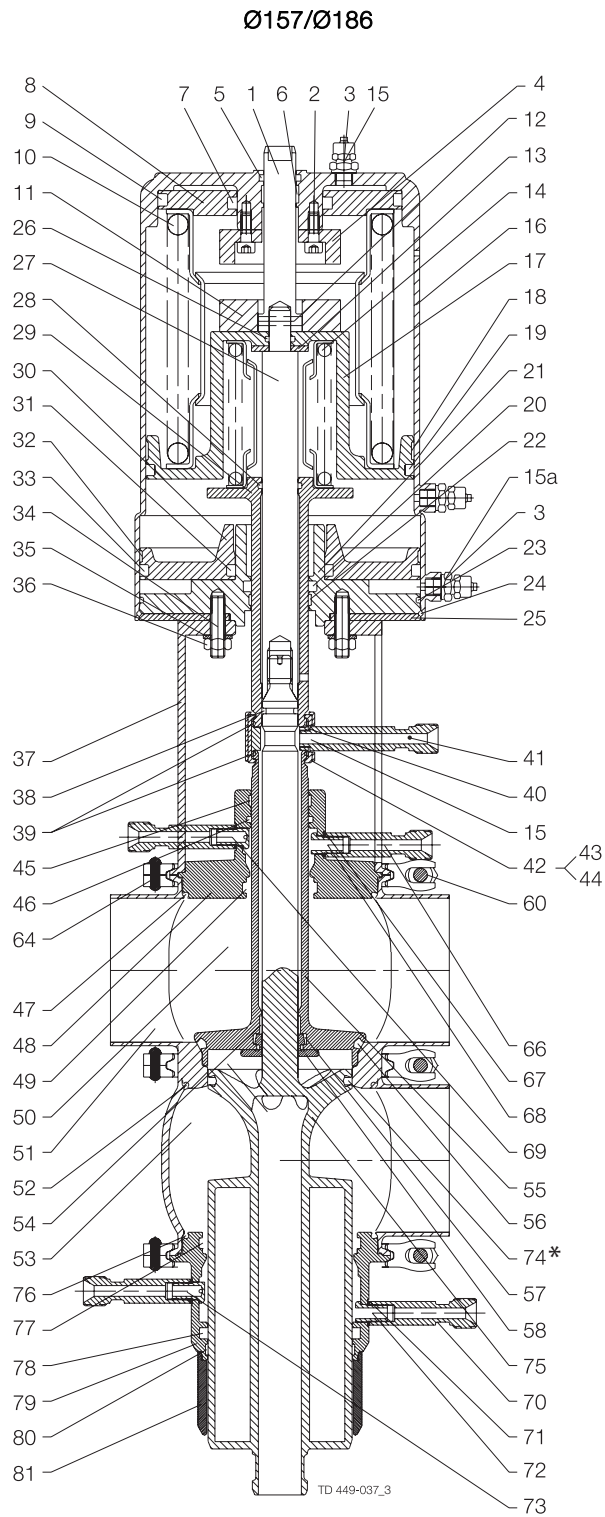

\* = All FPM service kits are supplied with EPDM seal ring (pos. 74)



## 7 Parts list and service kits

---

*It is important to observe the technical data during installation, operation and maintenance.  
Inform the personnel about the technical data.*

---

### Parts list

Pos.	Qty	Denomination
38	1	O-ring
39	2	O-ring
40	1	O-ring
46	1	O-ring
47	1	O-ring
49	1	Lip seal
52	1	O-ring
56	1	Seal ring
57	1	Lip seal
67	2	O-ring
71	2	O-ring
74	1	Seal ring
76	1	O-ring
77	1	Lip seal
78	1	O-ring

---

## 7 Parts list and service kits

It is important to observe the technical data during installation, operation and maintenance.  
Inform the personnel about the technical data.

### 7.3 Parts

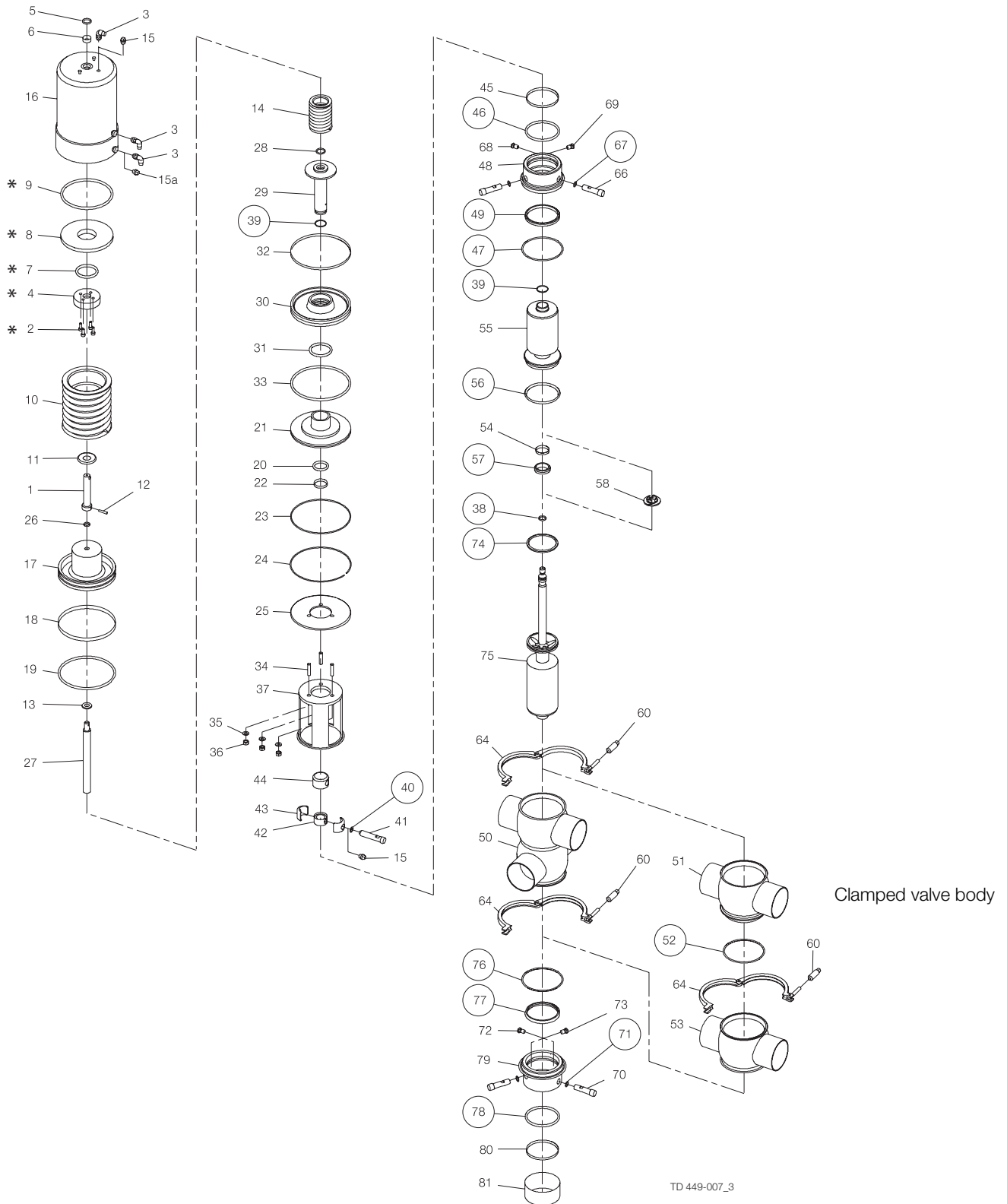

## 7 Parts list and service kits

*It is important to observe the technical data during installation, operation and maintenance.  
Inform the personnel about the technical data.*

### Parts list

Pos.	Qty	Denomination
1	1	Upper stem
2	4	Screw
3	3	Air fitting
4	1	Stop for upper piston
5 ●	1	O-ring
6 ●	1	Guide ring, Turcite
7 ●	1	O-ring
8	1	Upper piston
9 ●	1	O-ring
10	1	Spring assembly
11	1	Distance spacer
12	1	Pin
13	1	Washer
14	1	Spring assembly
15	1	Plug
15a	1	Plug
16	1	Cylinder
17	1	Main piston
18 ●	1	Guide ring, Turcite
19 ●	1	O-ring
20 ●	1	O-ring
21	1	Bottom
22 ●	1	Guide ring, Turcite
23 ●	1	O-ring
24	1	Retaining ring
25	1	Cover disk
26 ●	1	O-ring
27	1	Inner stem
28 ●	1	O-ring
29	1	Piston rod
30	1	Lower piston
31 ●	1	O-ring
32 ●	1	Guide ring, Turcite
33 ●	1	O-ring
34	3	Bolt
35	3	Washer
36	3	Nut
41	1	Flushing tube
42	1	Spindle liner
43	2	Clamp
44	1	Lock
45	1	Guide ring
48	1	Upper sealing element
54	1	Guide ring
55	1	Upper plug
58	1	Spray nozzle
60	2	Hexnut
61	2	Wingnut
64	2	Clamp without nut
66	2	Flushing tube
68	1	Drain
69	1	Nozzle
70	2	Flushing tube
72	1	Drain
73	1	Nozzle
75	1	Lower plug
79	1	Lower sealing element
80	1	Guide ring
81	1	Cover

## 7 Parts list and service kits

---

*It is important to observe the technical data during installation, operation and maintenance.  
Inform the personnel about the technical data.*

---

---

## 7 Parts list and service kits

*It is important to observe the technical data during installation, operation and maintenance.  
Inform the personnel about the technical data.*

### 7.4 Service kits (plug set-up 1-4)

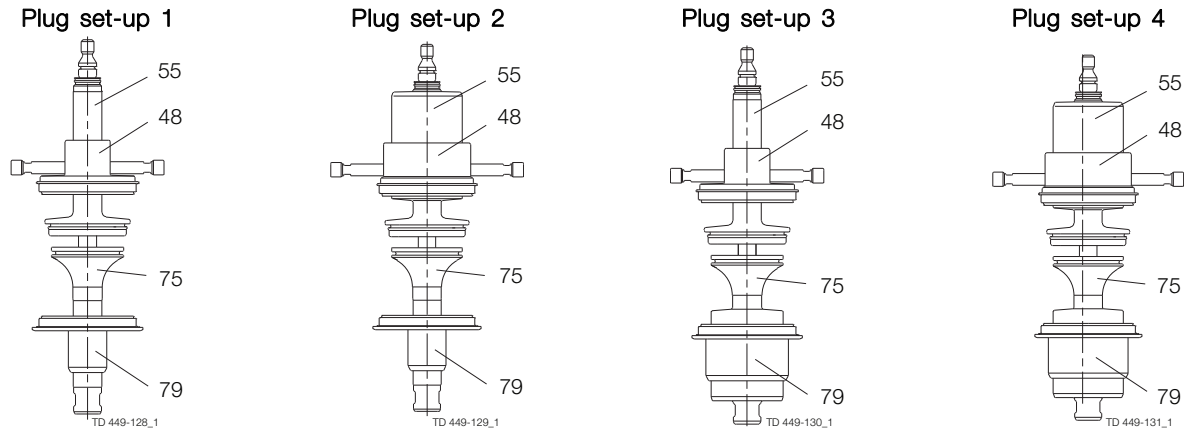

1. Find your plug/sealing element set-up.
2. Find the right pos. no. and plug set-up in the table and you have the part no.

An example:

1. Size DN 80, plug set-up 5
2. Pos. no. 55/plug set-up 5 has the part no. 9613-0082-02

## 7 Parts list and service kits

*It is important to observe the technical data during installation, operation and maintenance.  
Inform the personnel about the technical data.*

### Service kits

Denomination	DN/OD 38	DN/OD 51	DN/OD 63.5			
	DN 40 seat ø53.3	DN 50 seat ø53.3	DN 65 DN/OD 76.1 DN 80 seat ø81.3	*	**	DN 125 DN 150 seat ø115.3
<b>Plug set-up 1</b>						
Service kit, EPDM .....		9611-92-1550	9611-92-1552	9611-92-1554	9611-92-6334	9611-92-6025
Service kit, NBR .....		9611-92-1556	9611-92-1558	9611-92-1560	9611-92-6335	9611-92-6026
Service kit, FPM .....		9611-92-1562	9611-92-1564	9611-92-1566	9611-92-6336	9611-92-6027
Service kit, HNBR .....		9611-92-1568	9611-92-1570	9611-92-1572	9611-92-6337	9611-92-6028
<b>Plug set-up 2</b>						
Service kit, EPDM .....		9611-92-1574	9611-92-1576	9611-92-1578	9611-92-6338	9611-92-6029
Service kit, NBR .....		9611-92-1580	9611-92-1582	9611-92-1584	9611-92-6339	9611-92-6030
Service kit, FPM .....		9611-92-1586	9611-92-1588	9611-92-1590	9611-92-6340	9611-92-6031
Service kit, HNBR .....		9611-92-1592	9611-92-1594	9611-92-1596	9611-92-6341	9611-92-6032
<b>Plug set-up 3</b>						
Service kit, EPDM .....		9611-92-1598	9611-92-1599	9611-92-1602	9611-92-6342	9611-92-6033
Service kit, NBR .....		9611-92-1605	9611-92-1606	9611-92-1608	9611-92-6343	9611-92-6034
Service kit, FPM .....		9611-92-1611	9611-92-1612	9611-92-1614	9611-92-6344	9611-92-6035
Service kit, HNBR .....		9611-92-1617	9611-92-1618	9611-92-1620	9611-92-6345	9611-92-6036
<b>Plug set-up 4</b>						
Service kit, EPDM .....	9611-92-1622	9611-92-1623	9611-92-1624	9611-92-1626	9611-92-6346	9611-92-6037
Service kit, NBR .....	9611-92-1628	9611-92-1629	9611-92-1630	9611-92-1632	9611-92-6347	9611-92-6038
Service kit, FPM .....	9611-92-1634	9611-92-1635	9611-92-1636	9611-92-1638	9611-92-6348	9611-92-6039
Service kit, HNBR .....	9611-92-1640	9611-92-1641	9611-92-1642	9611-92-1644	9611-92-6349	9611-92-6040

\* = Serial no. below 1030000 - manufactured before 1. October 2003.

\*\* = Serial no. above 1030000 - manufactured after 1. October 2003.

#### NOTE!

**All FPM service kits are supplied with EPDM seal ring (pos. 74)**

If different connection size on upper and lower body, except for sizes DN 125 and DN 150, it is always the smallest body that determines the service kit.

**If clamped valve body an extra O-ring (pos. 52) is required.**

## 7 Parts list and service kits

*It is important to observe the technical data during installation, operation and maintenance.  
Inform the personnel about the technical data.*

### 7.5 Service kits (plug set-up 5-8)

Plug set-up 5

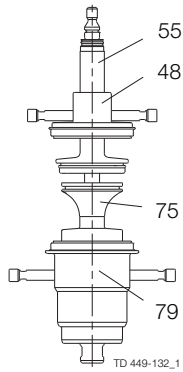

Plug set-up 6

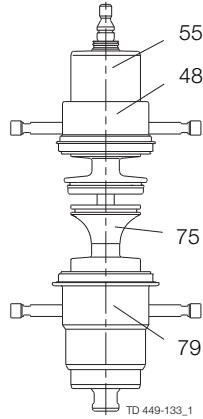

Plug set-up 7

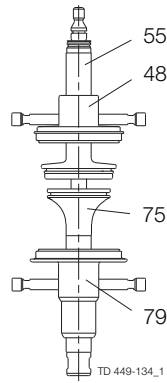

Plug set-up 8

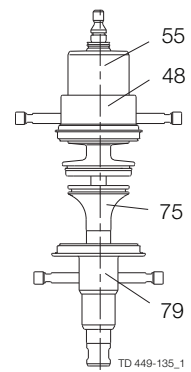

1. Find your plug/sealing element set-up.
2. Find the right pos. no. and plug set-up in the table and you have the part no.

An example:

1. Size DN 80, plug set-up 5
2. Pos. no. 55/plug set-up 5 has the part no. 9613-0082-02

## 7 Parts list and service kits

*It is important to observe the technical data during installation, operation and maintenance.  
Inform the personnel about the technical data.*

### Service kits

Denomination	DN/OD 38	DN/OD 51	DN/OD 63.5	DN/OD 76.1	DN/OD 101.6	DN/OD 101.6	DN 125
	DN 40 seat ø53.3	DN 50 seat ø53.3	DN 65 seat ø81.3	DN 80 seat ø115.3	*	**	DN 150 seat ø115.3
<b>Plug set-up 5</b>							
Service kit, EPDM .....		9611-92-1647	9611-92-1648	9611-92-1650	9611-92-6350	9611-92-6041	
Service kit, NBR .....		9611-92-1653	9611-92-1654	9611-92-1656	9611-92-6351	9611-92-6042	
Service kit, FPM .....		9611-92-1659	9611-92-1660	9611-92-1662	9611-92-6352	9611-92-6043	
Service kit, HNBR .....		9611-92-1665	9611-92-1666	9611-92-1668	9611-92-6353	9611-92-6044	
<b>Plug set-up 6</b>							
Service kit, EPDM .....	9611-92-1670	9611-92-1671	9611-92-1672	9611-92-1674	9611-92-6354	9611-92-6045	
Service kit, NBR .....	9611-92-1676	9611-92-1677	9611-92-1678	9611-92-1680	9611-92-6355	9611-92-6046	
Service kit, FPM .....	9611-92-1682	9611-92-1683	9611-92-1684	9611-92-1686	9611-92-6356	9611-92-6047	
Service kit, HNBR .....	9611-92-1688	9611-92-1689	9611-92-1690	9611-92-1692	9611-92-6357	9611-92-6048	
<b>Plug set-up 7</b>							
Service kit, EPDM .....		9611-92-1695	9611-92-1697	9611-92-1699	9611-92-6358	9611-92-6049	
Service kit, NBR .....		9611-92-1701	9611-92-1703	9611-92-1705	9611-92-6359	9611-92-6050	
Service kit, FPM .....		9611-92-1707	9611-92-1709	9611-92-1711	9611-92-6360	9611-92-6051	
Service kit, HNBR .....		9611-92-1713	9611-92-1715	9611-92-1717	9611-92-6361	9611-92-6052	
<b>Plug set-up 8</b>							
Service kit, EPDM .....		9611-92-1647	9611-92-1648	9611-92-1650	9611-92-6350	9611-92-6041	
Service kit, NBR .....		9611-92-1653	9611-92-1654	9611-92-1656	9611-92-6351	9611-92-6042	
Service kit, FPM .....		9611-92-1659	9611-92-1660	9611-92-1662	9611-92-6352	9611-92-6043	
Service kit, HNBR .....		9611-92-1665	9611-92-1666	9611-92-1668	9611-92-6353	9611-92-6044	

\* = Serial no. below 1030000 - manufactured before 1. October 2003.

\*\* = Serial no. above 1030000 - manufactured after 1. October 2003.

#### NOTE!

**All FPM service kits are supplied with EPDM seal ring (pos. 74)**

If different connection size on upper and lower body, except for sizes DN 125 and DN 150, it is always the smallest body that determines the service kit.

**If clamped valve body an extra O-ring (pos. 52) is required.**



## 7 Parts list and service kits

*It is important to observe the technical data during installation, operation and maintenance.  
Inform the personnel about the technical data.*

### 7.6 Service kits (plug set-up 9-12)

Plug set-up 9

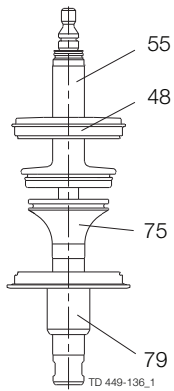

Plug set-up 10

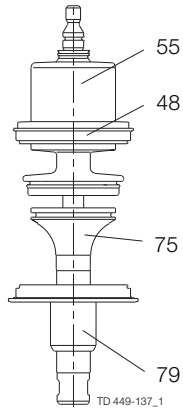

Plug set-up 11

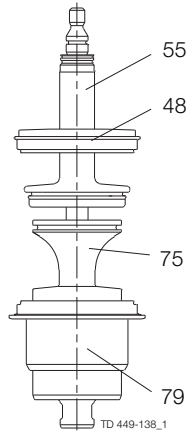

Plug set-up 12

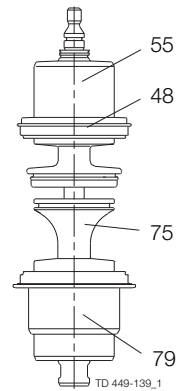

1. Find your plug/sealing element set-up.
2. Find the right pos. no. and plug set-up in the table and you have the part no.

An example:

1. Size DN 80, plug set-up 5
2. Pos. no. 55/plug set-up 5 has the part no. 9613-0082-02

## 7 Parts list and service kits

*It is important to observe the technical data during installation, operation and maintenance.  
Inform the personnel about the technical data.*

### Service kits

Denomination	DN/OD 38	DN/OD 51	DN/OD 63.5			
	DN 40 seat ø53.3	DN 50 seat ø53.3	DN 65 DN/OD 76.1 DN 80 seat ø81.3	*	**	DN 125 DN 150 seat ø115.3
<b>Plug set-up 9</b>						
Service kit, EPDM .....		9611-92-1743	9611-92-1745	9611-92-1747	9611-92-6362	9611-92-6057
Service kit, NBR .....		9611-92-1749	9611-92-1751	9611-92-1753	9611-92-6363	9611-92-6058
Service kit, FPM .....		9611-92-1755	9611-92-1757	9611-92-1759	9611-92-6364	9611-92-6059
Service kit, HNBR .....		9611-92-1761	9611-92-1763	9611-92-1765	9611-92-6365	9611-92-6060
<b>Plug set-up 10</b>						
Service kit, EPDM .....		9611-92-1767	9611-92-1769	9611-92-1771	9611-92-6366	9611-92-6061
Service kit, NBR .....		9611-92-1773	9611-92-1775	9611-92-1777	9611-92-6367	9611-92-6062
Service kit, FPM .....		9611-92-1779	9611-92-1781	9611-92-1783	9611-92-6368	9611-92-6063
Service kit, HNBR .....		9611-92-1785	9611-92-1787	9611-92-1789	9611-92-6369	9611-92-6064
<b>Plug set-up 11</b>						
Service kit, EPDM .....		9611-92-1767	9611-92-1769	9611-92-1771	9611-92-6366	9611-92-6061
Service kit, NBR .....		9611-92-1773	9611-92-1775	9611-92-1777	9611-92-6367	9611-92-6062
Service kit, FPM .....		9611-92-1779	9611-92-1781	9611-92-1783	9611-92-6368	9611-92-6063
Service kit, HNBR .....		9611-92-1785	9611-92-1787	9611-92-1789	9611-92-6369	9611-92-6064
<b>Plug set-up 12</b>						
Service kit, EPDM .....	9611-92-1814	9611-92-1815	9611-92-1816	9611-92-1818	9611-92-6370	9611-92-6069
Service kit, NBR .....	9611-92-1820	9611-92-1821	9611-92-1822	9611-92-1824	9611-92-6371	9611-92-6070
Service kit, FPM .....	9611-92-1826	9611-92-1827	9611-92-1828	9611-92-1830	9611-92-6372	9611-92-6071
Service kit, HNBR .....	9611-92-1832	9611-92-1833	9611-92-1834	9611-92-1836	9611-92-6373	9611-92-6072

\* = Serial no. below 1030000 - manufactured before 1. October 2003.

\*\* = Serial no. above 1030000 - manufactured after 1. October 2003.

#### NOTE!

**All FPM service kits are supplied with EPDM seal ring (pos. 74)**

If different connection size on upper and lower body, except for sizes DN 125 and DN 150, it is always the smallest body that determines the service kit.

**If clamped valve body an extra O-ring (pos. 52) is required.**

## 7 Parts list and service kits

*It is important to observe the technical data during installation, operation and maintenance.  
Inform the personnel about the technical data.*

### 7.7 Service kits (plug set-up 13-16)

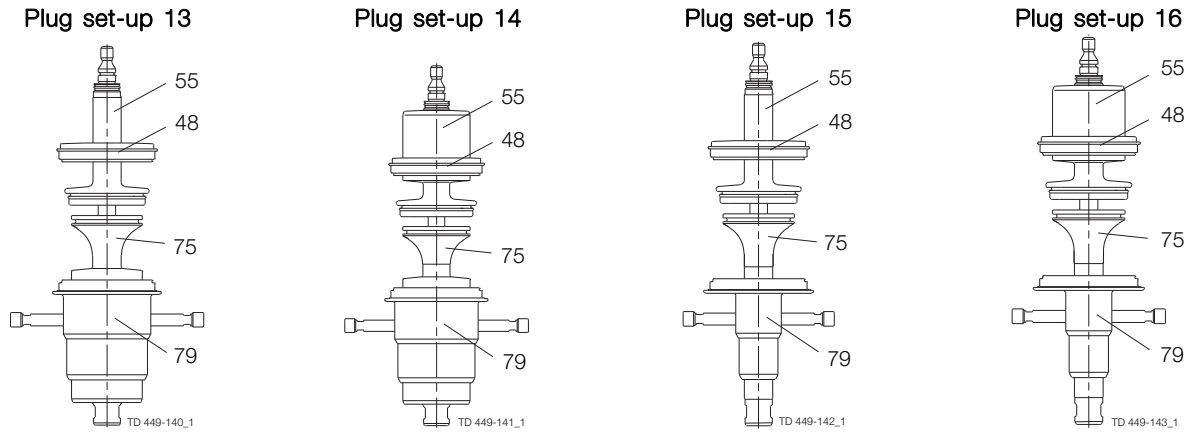

1. Find your plug/sealing element set-up.
2. Find the right pos. no. and plug set-up in the table and you have the part no.

An example:

1. Size DN 80, plug set-up 5
2. Pos. no. 55/plug set-up 5 has the part no. 9613-0082-02

## 7 Parts list and service kits

*It is important to observe the technical data during installation, operation and maintenance.  
Inform the personnel about the technical data.*

### Service kits

Denomination	DN/OD 38	DN/OD 51	DN/OD 63.5	*	**	DN 125
	DN 40 seat ø53.3	DN 50 seat ø53.3	DN/OD 76.1 DN 80 seat ø81.3	DN/OD 101.6 DN 100 seat ø115.3	DN/OD 101.6 DN 100 seat ø100.3	DN 150 seat ø115.3
<b>Plug set-up 13</b>						
Service kit, EPDM .....		9611-92-1574	9611-92-1576	9611-92-1578	9611-92-6338	9611-92-6029
Service kit, NBR .....		9611-92-1580	9611-92-1582	9611-92-1584	9611-92-6339	9611-92-6030
Service kit, FPM .....		9611-92-1586	9611-92-1588	9611-92-1590	9611-92-6340	9611-92-6031
Service kit, HNBR .....		9611-92-1592	9611-92-1594	9611-92-1596	9611-92-6341	9611-92-6032
<b>Plug set-up 14</b>						
Service kit, EPDM .....	9611-92-1622	9611-92-1623	9611-92-1624	9611-92-1626	9611-92-6346	9611-92-6037
Service kit, NBR .....	9611-92-1628	9611-92-1629	9611-92-1630	9611-92-1632	9611-92-6347	9611-92-6038
Service kit, FPM .....	9611-92-1634	9611-92-1635	9611-92-1636	9611-92-1638	9611-92-6348	9611-92-6039
Service kit, HNBR .....	9611-92-1640	9611-92-1641	9611-92-1642	9611-92-1644	9611-92-6349	9611-92-6040
<b>Plug set-up 15</b>						
Service kit, EPDM .....		9611-92-1550	9611-92-1552	9611-92-1554	9611-92-6334	9611-92-6025
Service kit, NBR .....		9611-92-155	9611-92-1558	9611-92-1560	9611-92-6335	9611-92-6026
Service kit, FPM .....		9611-92-1562	9611-92-1564	9611-92-1566	9611-92-6336	9611-92-6027
Service kit, HNBR .....		9611-92-1568	9611-92-1570	9611-92-1572	9611-92-6337	9611-92-6027
<b>Plug set-up 16</b>						
Service kit, EPDM .....		9611-92-1598	9611-92-1599	9611-92-1602	9611-92-6342	9611-92-6033
Service kit, NBR .....		9611-92-1605	9611-92-1606	9611-92-1608	9611-92-6343	9611-92-6034
Service kit, FPM .....		9611-92-1611	9611-92-1612	9611-92-1614	9611-92-6344	9611-92-6035
Service kit, HNBR .....		9611-92-1617	9611-92-1618	9611-92-1620	9611-92-6345	9611-92-6036

\* = Serial no. below 1030000 - manufactured before 1. October 2003.

\*\* = Serial no. above 1030000 - manufactured after 1. October 2003.

#### NOTE!

**All FPM service kits are supplied with EPDM seal ring (pos. 74)**

If different connection size on upper and lower body, except for sizes DN 125 and DN 150, it is always the smallest body that determines the service kit.

**If clamped valve body an extra O-ring (pos. 52) is required.**

## 7 Parts list and service kits

*It is important to observe the technical data during installation, operation and maintenance.  
Inform the personnel about the technical data.*

### 7.8 Service kits - mix with DN125, DN150, Sch. 5 5" and Sch. 5 6" (plug set-up 1-4)

Plug set-up 1

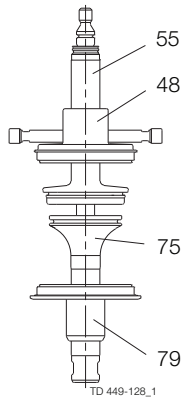

Plug set-up 2

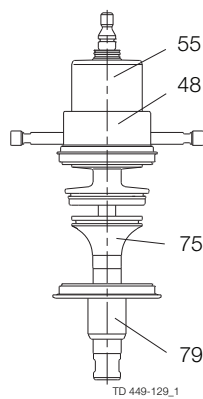

Plug set-up 3

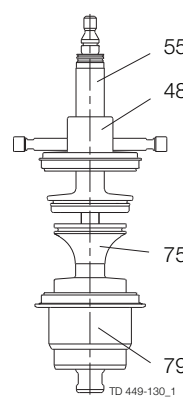

Plug set-up 4

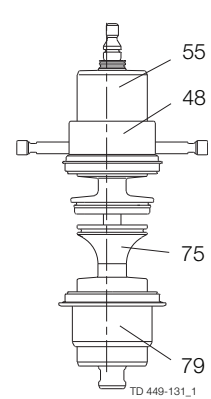

1. Find your plug/sealing element set-up.
2. Find the right pos. no. and plug set-up in the table and you have the part no.

An example:

1. Size DN 80, plug set-up 5
2. Pos. no. 55/plug set-up 5 has the part no. 9613-0082-02

## 7 Parts list and service kits

*It is important to observe the technical data during installation, operation and maintenance.  
Inform the personnel about the technical data.*

### Service kits

Denomination	DN/OD 38	DN/OD 51	DN/OD 63.5	*	**
	DN 40 seat ø53.3	DN 50 seat ø53.3	DN 65 DN/OD 76.1 DN 80 seat ø81.3	DN/OD 101.6 DN 100 seat ø115.3	DN/OD 101.6 DN 100 seat ø100.3
<b>Plug set-up 1</b>					
Service kit, EPDM .....		9611-92-6105	9611-92-6169	9611-92-6233	9611-92-6374
Service kit, NBR .....		9611-92-6106	9611-92-6170	9611-92-6234	9611-92-6375
Service kit, FPM .....		9611-92-6107	9611-92-6171	9611-92-6235	9611-92-6376
Service kit, HNBR .....		9611-92-6108	9611-92-6172	9611-92-6236	9611-92-6377
<b>Plug set-up 2</b>					
Service kit, EPDM .....		9611-92-6109	9611-92-6173	9611-92-6237	9611-92-6378
Service kit, NBR .....		9611-92-6110	9611-92-6174	9611-92-6238	9611-92-6379
Service kit, FPM .....		9611-92-6111	9611-92-6175	9611-92-6239	9611-92-6380
Service kit, HNBR .....		9611-92-6112	9611-92-6176	9611-92-6240	9611-92-6381
<b>Plug set-up 3</b>					
Service kit, EPDM .....		9611-92-6113	9611-92-6177	9611-92-6241	9611-92-6382
Service kit, NBR .....		9611-92-6114	9611-92-6178	9611-92-6242	9611-92-6383
Service kit, FPM .....		9611-92-6115	9611-92-6179	9611-92-6243	9611-92-6384
Service kit, HNBR .....		9611-92-6116	9611-92-6180	9611-92-6244	9611-92-6385
<b>Plug set-up 4</b>					
Service kit, EPDM .....	9611-92-6089	9611-92-6117	9611-92-6181	9611-92-6245	9611-92-6386
Service kit, NBR .....	9611-92-6090	9611-92-6118	9611-92-6182	9611-92-6246	9611-92-6387
Service kit, FPM .....	9611-92-6091	9611-92-6119	9611-92-6183	9611-92-6247	9611-92-6388
Service kit, HNBR .....	9611-92-6092	9611-92-6120	9611-92-6184	9611-92-6248	9611-92-6389

\* = Serial no. below 1030000 - manufactured before 1. October 2003.

\*\* = Serial no. above 1030000 - manufactured after 1. October 2003.

#### NOTE!

All FPM service kits are supplied with EPDM seal ring (pos. 74)

If clamped valve body an extra O-ring (pos. 52) is required.

## 7 Parts list and service kits

*It is important to observe the technical data during installation, operation and maintenance.  
Inform the personnel about the technical data.*

### 7.9 Service kits - mix with DN125, DN150, Sch. 5 5" and Sch. 5 6" (plug set-up 5-8)

Plug set-up 5

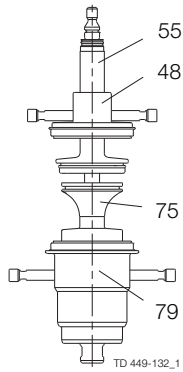

Plug set-up 6

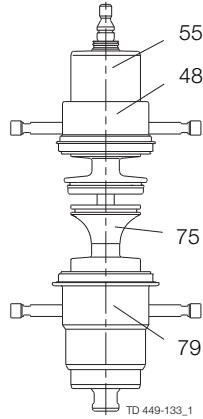

Plug set-up 7

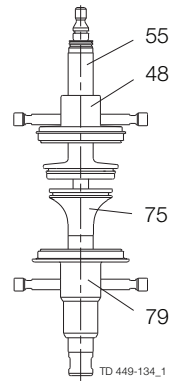

Plug set-up 8

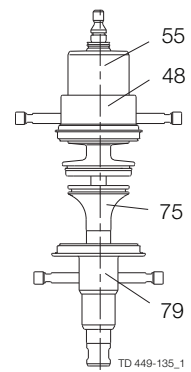

1. Find your plug/sealing element set-up.
2. Find the right pos. no. and plug set-up in the table and you have the part no.

An example:

1. Size DN 80, plug set-up 5
2. Pos. no. 55/plug set-up 5 has the part no. 9613-0082-02

## 7 Parts list and service kits

*It is important to observe the technical data during installation, operation and maintenance.  
Inform the personnel about the technical data.*

### Service kits

Denomination	DN/OD 38	DN/OD 51	DN/OD 63.5	*	**
	DN 40 seat ø53.3	DN 50 seat ø53.3	DN 65 DN/OD 76.1 DN 80 seat ø81.3	DN/OD 101.6 DN 100 seat ø115.3	DN/OD 101.6 DN 100 seat ø100.3
<b>Plug set-up 5</b>					
Service kit, EPDM .....		9611-92-6121	9611-92-6185	9611-92-6249	9611-92-6390
Service kit, NBR .....		9611-92-6122	9611-92-6186	9611-92-6250	9611-92-6391
Service kit, FPM .....		9611-92-6123	9611-92-6187	9611-92-6251	9611-92-6392
Service kit, HNBR .....		9611-92-6124	9611-92-6188	9611-92-6252	9611-92-6393
<b>Plug set-up 6</b>					
Service kit, EPDM .....	9611-92-6093	9611-92-6125	9611-92-6189	9611-92-6253	9611-92-6394
Service kit, NBR .....	9611-92-6094	9611-92-6126	9611-92-6190	9611-92-6254	9611-92-6395
Service kit, FPM .....	9611-92-6095	9611-92-6127	9611-92-6191	9611-92-6255	9611-92-6396
Service kit, HNBR .....	9611-92-6096	9611-92-6128	9611-92-6192	9611-92-6256	9611-92-6397
<b>Plug set-up 7</b>					
Service kit, EPDM .....		9611-92-6129	9611-92-6193	9611-92-6257	9611-92-6398
Service kit, NBR .....		9611-92-6130	9611-92-6194	9611-92-6258	9611-92-6399
Service kit, FPM .....		9611-92-6131	9611-92-6195	9611-92-6259	9611-92-6400
Service kit, HNBR .....		9611-92-6132	9611-92-6196	9611-92-6260	9611-92-6401
<b>Plug set-up 8</b>					
Service kit, EPDM .....		9611-92-6121	9611-92-6185	9611-92-6249	9611-92-6390
Service kit, NBR .....		9611-92-6122	9611-92-6186	9611-92-6250	9611-92-6391
Service kit, FPM .....		9611-92-6123	9611-92-6187	9611-92-6251	9611-92-6392
Service kit, HNBR .....		9611-92-6124	9611-92-6188	9611-92-6252	9611-92-6393

\* = Serial no. below 1030000 - manufactured before 1. October 2003.

\*\* = Serial no. above 1030000 - manufactured after 1. October 2003.

#### NOTE!

All FPM service kits are supplied with EPDM seal ring (pos. 74)

If clamped valve body an extra O-ring (pos. 52) is required.



## 7 Parts list and service kits

*It is important to observe the technical data during installation, operation and maintenance.  
Inform the personnel about the technical data.*

### 7.10 Service kits - mix with DN125, DN150, Sch. 5 5" and Sch. 5 6" (plug set-up 9-12)

Plug set-up 9

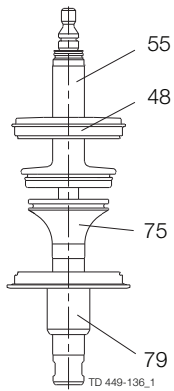

Plug set-up 10

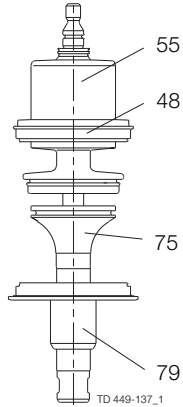

Plug set-up 11

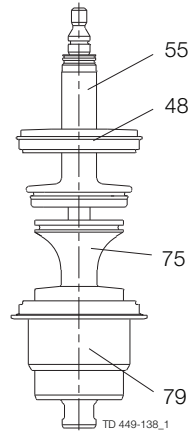

Plug set-up 12

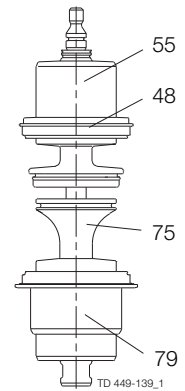

1. Find your plug/sealing element set-up.
2. Find the right pos. no. and plug set-up in the table and you have the part no.

An example:

1. Size DN 80, plug set-up 5
2. Pos. no. 55/plug set-up 5 has the part no. 9613-0082-02

## 7 Parts list and service kits

*It is important to observe the technical data during installation, operation and maintenance.  
Inform the personnel about the technical data.*

### Service kits

Denomination	DN/OD 38	DN/OD 51	DN/OD 63.5	*	**
	DN 40 seat ø53.3	DN 50 seat ø53.3	DN 65 DN/OD 76.1 DN 80 seat ø81.3	DN/OD 101.6 DN 100 seat ø115.3	DN/OD 101.6 DN 100 seat ø100.3
<b>Plug set-up 9</b>					
Service kit, EPDM .....		9611-92-6137	9611-92-6201	9611-92-6265	9611-92-6402
Service kit, NBR .....		9611-92-6138	9611-92-6202	9611-92-6266	9611-92-6403
Service kit, FPM .....		9611-92-6139	9611-92-6203	9611-92-6267	9611-92-6404
Service kit, HNBR .....		9611-92-6140	9611-92-6204	9611-92-6268	9611-92-6405
<b>Plug set-up 10</b>					
Service kit, EPDM .....		9611-92-6141	9611-92-6205	9611-92-6269	9611-92-6406
Service kit, NBR .....		9611-92-6142	9611-92-6206	9611-92-6270	9611-92-6407
Service kit, FPM .....		9611-92-6143	9611-92-6207	9611-92-6271	9611-92-6408
Service kit, HNBR .....		9611-92-6144	9611-92-6208	9611-92-6272	9611-92-6409
<b>Plug set-up 11</b>					
Service kit, EPDM .....		9611-92-6141	9611-92-6205	9611-92-6269	9611-92-6406
Service kit, NBR .....		9611-92-6142	9611-92-6206	9611-92-6270	9611-92-6407
Service kit, FPM .....		9611-92-6143	9611-92-6207	9611-92-6271	9611-92-6408
Service kit, HNBR .....		9611-92-6144	9611-92-6208	9611-92-6272	9611-92-6409
<b>Plug set-up 12</b>					
Service kit, EPDM .....	9611-92-6097	9611-92-6149	9611-92-6213	9611-92-6277	9611-92-6410
Service kit, NBR .....	9611-92-6098	9611-92-6150	9611-92-6214	9611-92-6278	9611-92-6411
Service kit, FPM .....	9611-92-6099	9611-92-6151	9611-92-6215	9611-92-6279	9611-92-6412
Service kit, HNBR .....	9611-92-6100	9611-92-6152	9611-92-6216	9611-92-6280	9611-92-6413

\* = Serial no. below 1030000 - manufactured before 1. October 2003.

\*\* = Serial no. above 1030000 - manufactured after 1. October 2003.

#### NOTE!

All FPM service kits are supplied with EPDM seal ring (pos. 74)

If clamped valve body an extra O-ring (pos. 52) is required.

## 7 Parts list and service kits

*It is important to observe the technical data during installation, operation and maintenance.  
Inform the personnel about the technical data.*

### 7.11 Service kits - mix with DN125, DN150, Sch. 5 5" and Sch. 5 6" (plug set-up 13-16)

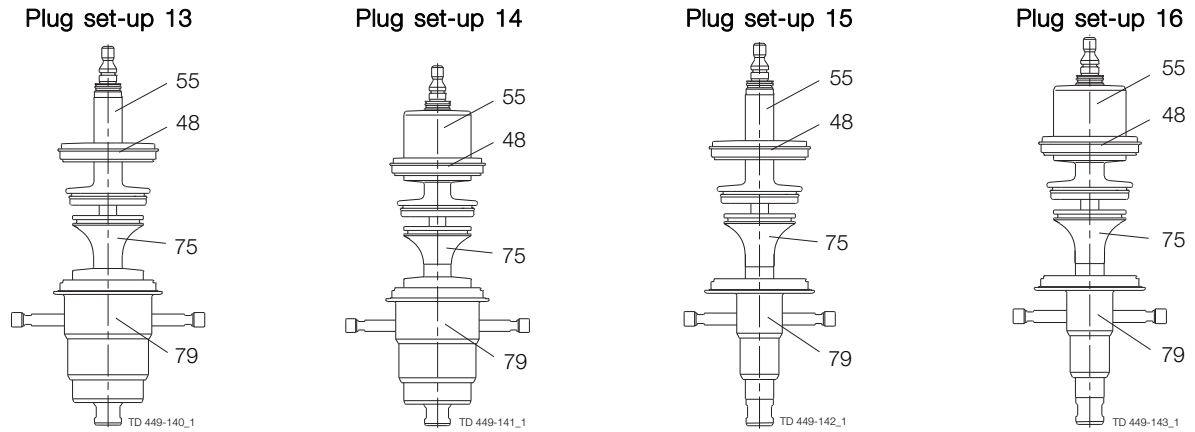

1. Find your plug/sealing element set-up.
2. Find the right pos. no. and plug set-up in the table and you have the part no.

An example:

1. Size DN 80, plug set-up 5
2. Pos. no. 55/plug set-up 5 has the part no. 9613-0082-02

## 7 Parts list and service kits

*It is important to observe the technical data during installation, operation and maintenance.  
Inform the personnel about the technical data.*

### Service kits

Denomination	DN/OD 38	DN/OD 51	DN/OD 63.5	*	**
	DN 40 seat ø53.3	DN 50 seat ø53.3	DN 65 DN/OD 76.1 DN 80 seat ø81.3	DN/OD 101.6 DN 100 seat ø115.3	DN/OD 101.6 DN 100 seat ø100.3
<b>Plug set-up 13</b>					
Service kit, EPDM .....		9611-92-6109	9611-92-6173	9611-92-6237	9611-92-6378
Service kit, NBR .....		9611-92-6110	9611-92-6174	9611-92-6238	9611-92-6379
Service kit, FPM .....		9611-92-6111	9611-92-6175	9611-92-6239	9611-92-6380
Service kit, HNBR .....		9611-92-6112	9611-92-6176	9611-92-6240	9611-92-6381
<b>Plug set-up 14</b>					
Service kit, EPDM .....	9611-92-6089	9611-92-6117	9611-92-6181	9611-92-6245	9611-92-6386
Service kit, NBR .....	9611-92-6090	9611-92-6118	9611-92-6182	9611-92-6246	9611-92-6387
Service kit, FPM .....	9611-92-6091	9611-92-6119	9611-92-6183	9611-92-6247	9611-92-6388
Service kit, HNBR .....	9611-92-6092	9611-92-6120	9611-92-6184	9611-92-6248	9611-92-6389
<b>Plug set-up 15</b>					
Service kit, EPDM .....		9611-92-6105	9611-92-6169	9611-92-6233	9611-92-6374
Service kit, NBR .....		9611-92-6106	9611-92-6170	9611-92-6234	9611-92-6375
Service kit, FPM .....		9611-92-6107	9611-92-6171	9611-92-6235	9611-92-6376
Service kit, HNBR .....		9611-92-6108	9611-92-6172	9611-92-6236	9611-92-6377
<b>Plug set-up 16</b>					
Service kit, EPDM .....		9611-92-6113	9611-92-6177	9611-92-6241	9611-92-6382
Service kit, NBR .....		9611-92-6114	9611-92-6178	9611-92-6242	9611-92-6383
Service kit, FPM .....		9611-92-6115	9611-92-6179	9611-92-6243	9611-92-6384
Service kit, HNBR .....		9611-92-6116	9611-92-6180	9611-92-6244	9611-92-6385

\* = Serial no. below 1030000 - manufactured before 1. October 2003.

\*\* = Serial no. above 1030000 - manufactured after 1. October 2003.

#### NOTE!

All FPM service kits are supplied with EPDM seal ring (pos. 74)

If clamped valve body an extra O-ring (pos. 52) is required.

*It is important to observe the technical data during installation, operation and maintenance.  
Inform the personnel about the technical data.*

### 7.12 Axial installation tool

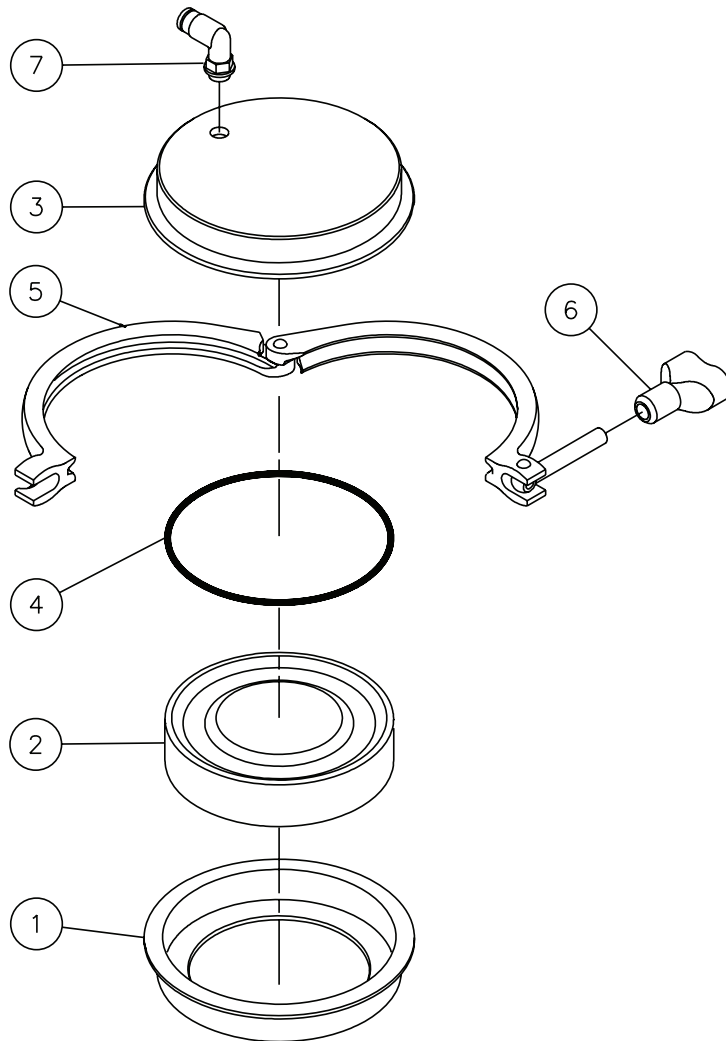

TD 449-038\_1

## 7 Parts list and service kits

---

*It is important to observe the technical data during installation, operation and maintenance.  
Inform the personnel about the technical data.*

---

### Parts list

Pos.	Qty	Denomination
1	1	Lower Part
2	1	Piston
3	1	Upper Part
4	1	O-ring, NBR
5	1	Clamp
6	1	Wingnut
7	1	Air fitting

---

*It is important to observe the technical data during installation, operation and maintenance.  
Inform the personnel about the technical data.*

### 7.13 Radial installation tool

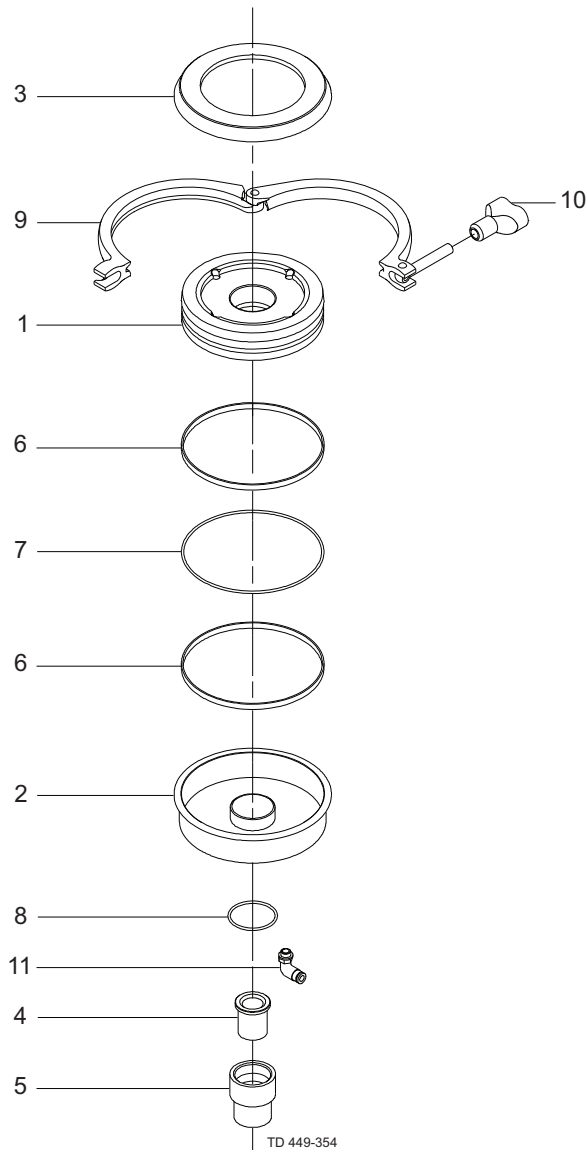

## 7 Parts list and service kits

---

*It is important to observe the technical data during installation, operation and maintenance.  
Inform the personnel about the technical data.*

---

### Parts list

Pos.	Qty	Denomination
1	1	Piston
2	1	Lower Part
3	1	Upper Part
4	1	Bushing
5	1	Guide
6	2	Guide ring
7	1	O-ring, NBR
8	1	O-ring, NBR
9	1	Clamp
10	1	Wingnut
11	1	Air fitting

---



---

**How to contact Alfa Laval**

Contact details for all countries are continually updated on our website.

Please visit [www.alfalaval.com](http://www.alfalaval.com) to access the information directly.

© Alfa Laval Corporate AB

This document and its contents is owned by Alfa Laval Corporate AB and protected by laws governing intellectual property and thereto related rights. It is the responsibility of the user of this document to comply with all applicable intellectual property laws. Without limiting any rights related to this document, no part of this document may be copied, reproduced or transmitted in any form or by any means (electronic, mechanical, photocopying, recording, or otherwise), or for any purpose, without the expressed permission of Alfa Laval Corporate AB. Alfa Laval Corporate AB will enforce its rights related to this document to the fullest extent of the law, including the seeking of criminal prosecution.